



COPY RIGHT

2017 IJIEMR. Personal use of this material is permitted. Permission from IJIEMR must be obtained for all other uses, in any current or future media, including reprinting/republishing this material for advertising or promotional purposes, creating new collective works, for resale or redistribution to servers or lists, or reuse of any copyrighted component of this work in other works. No Reprint should be done to this paper, all copy right is authenticated to Paper Authors

IJIEMR Transactions, online available on 12th October 2017. Link :

<http://www.ijiemr.org/downloads.php?vol=Volume-6&issue=ISSUE-09>

Title: A Novel Hybrid-Fuzzy Logic Control Scheme for Seamless Mode Transfer in micro grid System.

Volume 06, Issue 09, Page No: 487 – 495.

Paper Authors

***MALOTH LAXMAN, BHUKYA VINOD.**

* Dept of EEE, Krishna Murthi Engineering College.



USE THIS BARCODE TO ACCESS YOUR ONLINE PAPER

To Secure Your Paper As Per **UGC Guidelines** We Are Providing A Electronic Bar Code

A NOVEL HYBRID-FUZZY LOGIC CONTROL SCHEME FOR SEAMLESS MODE TRANSFER IN MICRO GRID SYSTEM

*MALOTH LAXMAN, **BHUKYA VINOD

*Assistant Professor, Dept of EEE, Krishna Murthi Engineering College.

**Assistant Professor, Dept of EEE, Krishna Murthi Engineering College.

ABSTRACT-

The micro-grid is an approach to solve distributed generations (DG) interconnecting with power grid to realize the accurate power-flow control. A complete control system of smart micro grid is proposed in order to realize the seamless mode transfer of the grid-connected mode (GTM) and islanding mode (ILM). In this system, every DG unit will work as the voltage source and use the same control method of output voltage; whatever in GTM or ILM. The only difference of GTM and ILM is how to regulate the reference voltage of the voltage control. Meanwhile, a grid-tracking control loop is proposed in order to synchronize the AC bus of microgrid with the grid before microgrid switches from ILM to GTM. Finally, the complete system with control strategies of the microgrid is build, and the experiment results of GTM, grid-tracking in ILM and mode transfers are presented, which validates the performance of the seamless mode transfer of the proposed control system. The advanced methods of fuzzy logic and hybrid fuzzy logic controllers are used in this project for excellent results of the two modes of transfer.

Key Words: Fuzzy logic controller, Seamless Mode Transfer, Grid Connected Mode, Islanding Mode.

I. INTRODUCTION

The applications of distributed generation (DG) systems are emerging and most will be interfaced to the grid through power-electronics converters. Distributed generation, also distributed energy, on-site generation (OSG) or district/decentralized energy is generated or stored by a variety of small, grid-connected devices referred to as distributed energy resources (DER) or distributed energy resource systems [1-4]. However, the grid will become much more complex due to the increasing number of DG systems. To give full play to the advantages of distributed power generation technology, one or more distributed power (DG), energy storage device and controllable load form a micro-grid according to certain topological structure.

A microgrid is a small-scale power grid that can operate independently or in conjunction with the area's main electrical grid. The practice of using microgrids is known as distributed, dispersed, decentralized, district or

embedded energy generation [5]. A microgrid is a group of interconnected loads and distributed energy resources (DERs) within clearly defined electrical boundaries that acts as a single controllable entity with respect to the grid. A microgrid can connect and disconnect from the grid to enable it to operate in both grid-connected or island-mode.

Grid-connected mode is when micro-grid is connected to the main grid and island mode is when micro-grid is isolated from the main grid. Both are normal operation status of micro-grid. Proper control strategy is key to the steady operation of micro-grid [6],[7]. Micro-grid seamless switchover between grid connected mode and island mode is the emphasis and difficulty of micro-grid control strategy research and is important for steady operation and reliable power supply of micro-grid.

The proposed Micro grid can operate in a grid-tied mode and islanding mode. The coordination control algorithms are proposed for seamless power transfer between ac and dc

links and for stable system operation under various generation and load conditions [8]. In this paper GTM adopts an improved grid-tied control strategy of voltage-source inverter. ILM adopts an improved parallel-operation control strategy. The proposed scheme is implemented by using different controller like PI, fuzzy and hybrid controllers by using MATLAB/SIMULINK Software.

II. STRUCTURE OF MICROGRID SYSTEM

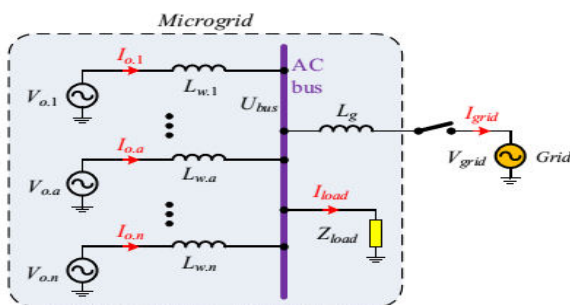

Fig.1. Diagram of microgrid system

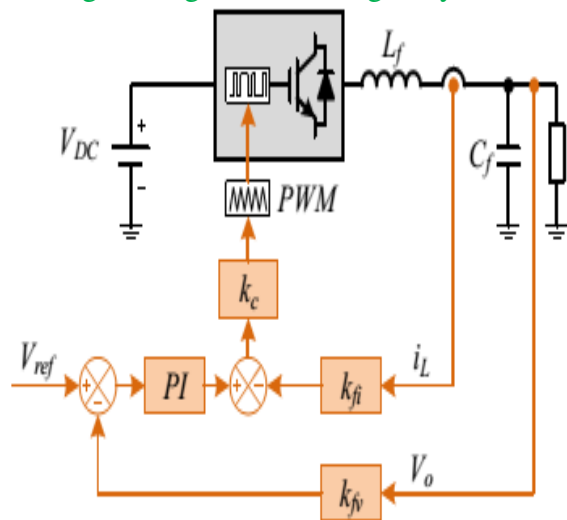

Fig.2. Control method of output voltage

Fig.1 expresses the diagram of microgrid system, which consists of n voltages-source inverters. The letter “a” represents any inverter in the system. $V_{o,a}$ and $I_{o,a}$ is the output voltage and current of any inverter respectively, $L_{w,a}$ is the wire inductor between the inverter and AC bus, which comply with the relation of (1).

$$k_a \cdot L_{w,a} = L_e \quad (a=1..n) \quad (1)$$

In this equation, k_a is the weighted coefficient of every inverter, which is related with the rated output power $S_{R,a}$ SR.a of every inverter, as shown in (2).

$$k_a = \frac{S_{R,a}}{\sum_{j=1}^n S_{R,j}} \quad (2)$$

In the microgrid, every VSI inverter will work as a robust voltage source and use the same control method of output voltage, whatever in GTM or ILM. The voltage control method is presented as shown in 0. The only difference of GTM and ILM is how to regulate the reference voltage V_{ref} of every inverter.

III. CONTROL STRATEGY IN GRID-TIED MODE

The principle of grid-tied control strategy of VSI in GTM can be described as Fig.3. And the control equation of every inverter is presented as (3).

$$\begin{cases} \omega_{a,k} = \omega_{a,k-1} - m_{\omega,a} (P_{o,a,k-1} - P_{ref,a,k-1}) \\ V_{a,k} = V_{a,k-1} - n_{v,a} (Q_{o,a,k-1} - Q_{ref,a,k-1}) \end{cases} \quad (3)$$

In this equation, the letter k and $k-1$ represents the k th and $(k-1)$ th control cycle, ω_a and V_a is the angular frequency and amplitude of the inverter's voltage. Meanwhile, $\omega_{0,a}$ and $V_{0,a}$ is the initial value of ω_a and V_a when k equals to 0, and the initial value is defined as the rated angular frequency ω_r and the rated amplitude V_r .

Moreover, $P_{o,a}$ and $Q_{o,a}$ is the actual active and reactive output power of VSI, $m_{\omega,a}$ and $n_{v,a}$ is the droop control coefficient of $P_{o,a}$ and $Q_{o,a}$ which complies with the relation of (4). $P_{ref,a}$ and $Q_{ref,a}$ is the assigned active and reactive power of VSI injected to the grid which is determined by itself.

$$\begin{cases} m_{\omega,a} \cdot k_a = m_{\omega,e} \\ n_{v,a} \cdot k_a = n_{v,e} \end{cases} \quad (a=1..n) \quad (4)$$

The FFT module is used to analyze the harmonic components of grid voltage. Based on

the results of FFT module, the harmonic compensation module will calculate the harmonic reference voltage $V_{ref,H}$ to simulate the harmonics of grid, which is used to eliminate the harmonic current injected into the grid. In the harmonic compensation, only the low frequency odd harmonics will be analyzed, such as 3rd - 9th odd harmonics, and the high-frequency harmonics will be ignored.

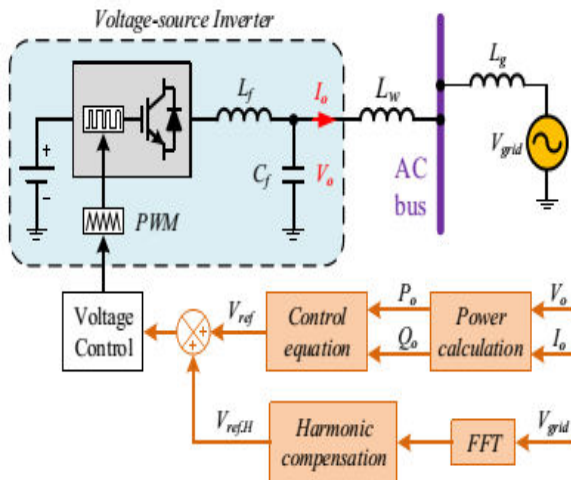

Fig.3. Control strategy of VSI in GTM

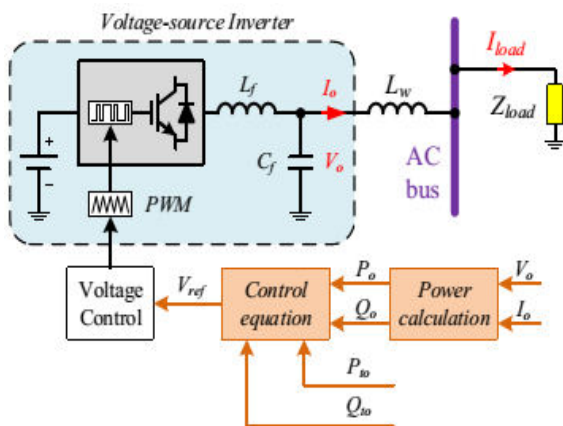

Fig.4. Control strategy of VSI in ILM

IV. CONTROL STRATEGY OF ISLANDING MODE

The principle of islanding control strategy can be described as Fig.4, which is proposed. The control equation of every inverter is presented as (5), which is analogous to (3). In this

equation $m_{\omega,a}$ and $n_{\omega,a}$ also complies with the relation as shown in (4).

$$\begin{cases} \omega_{a,k} = \omega_r - m_{\omega,a} (P_{o,a,k-1} - P_{ref,a,k-1}) \\ V_{a,k} = V_{a,k-1} - n_{v,a} (Q_{o,a,k-1} - Q_{ref,a,k-1}) \end{cases} \quad (5)$$

The major difference of (3) and (5) is, (5) replace $\omega_{a,k-1}$ with the rated angular frequency ω_r . The reason is that, the AC bus voltage U_{bus} is controlled by grid in GTM, and controlled by SIs in ILM. Therefore, every VSI should track the frequency of grid In GTM, which has a certain variation range. While in ILM, every VSI should have a fixed frequency reference to sustain U_{bus} stable.

Moreover, $P_{ref,a}$ and $Q_{ref,a}$ in ILM is determined by the load sharing of microgrid, which is calculated by (6). Therefore the realization of (6) needs communication among VSIs to analysis the active and reactive power of the whole microgrid system.

$$\begin{cases} P_{ref,a} = k_a \cdot P_{to} = k_a \sum_{j=1}^n P_{o,j} \\ Q_{ref,a} = k_a \cdot Q_{to} = k_a \sum_{j=1}^n Q_{o,j} \end{cases} \quad (6)$$

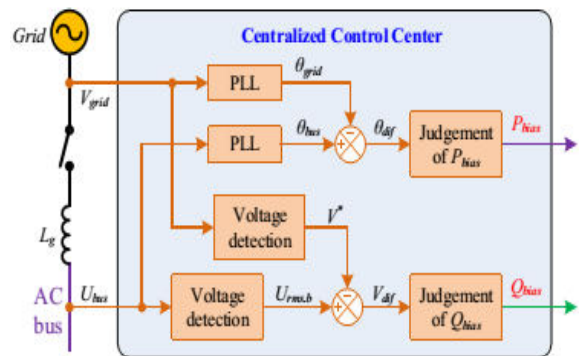

Fig.5. Grid-tracking control strategy

V. GRID-TRACKING CONTROL STRATEGY

The AC bus voltage U_{bus} of microgrid should be synchronized with the grid voltage V_{grid} before microgrid switches from ILM to GTM. In this paper, a grid-tracking control strategy is proposed to solve this problem. This method works as an additional loop of the

control strategy of ILM to ensure U_{bus} has the same amplitude, phase and frequency with V_{grid} , and it will be deactivated when the grid is abnormal or unavailable.

The proposed grid-tracking method is realized by introducing the bias power P_{bias} and Q_{bias} in (5), which is shown as (7). And the diagram of this method can be presented as shown in Fig.5.

$$\begin{cases} \omega_{a,k} = \omega_r - m_{\omega,a}(P_{o,a,k-1} - P_{ref,a,k-1}) - m_{\omega,a}k_a \cdot P_{bias,k-1} \\ V_{a,k} = V_{a,k-1} - n_{v,a}(Q_{o,a,k-1} - Q_{ref,a,k-1}) - n_{v,a}k_a \cdot Q_{bias,k-1} \end{cases} \quad (7)$$

In this method, a centralized control center (3C) is used to measure and analyze the voltages of AC bus and grid, and send the same P_{bias} and Q_{bias} to every VSI. The principle of phase tracking and voltage tracking can be presented by Fig.6 and Fig.7.

As shown in the two figures, when the grid is normal, 3C will calculate the phase difference θ_{dif} and amplitude difference V_{dif} of U_{bus} and V_{grid} . Subsequently, P_{bias} and Q_{bias} will be assigned a fixed value respectively according to the polarity of θ_{dif} and V_{dif} . The fixed value should guarantee U_{bus} can synchronize with V_{grid} during a given period, and avoid the voltage jump of U_{bus} . When the grid is abnormal or unavailable, 3C will assign 0 to P_{bias} , so every VSI can control freely its own frequency around the rated angular frequency ω_r . Meanwhile, 3C will calculate the amplitude difference of U_{bus} and the rated value V_r and guarantee the amplitude of U_{bus} in a reasonable range by Q_{bias} .

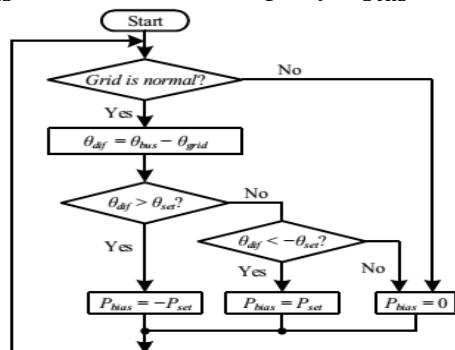

Fig.6. Control method of phase tracking

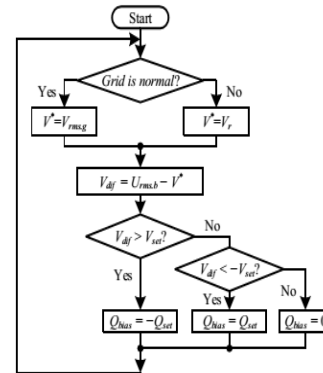

Fig.7. Control method of amplitude tracking

VI. FUZZY LOGIC CONTROLLER

The word Fuzzy means vagueness. Fuzziness occurs when the boundary of piece of information is not clear-cut. In 1965 Lotfi A. Zahed propounded the fuzzy set theory. Fuzzy set theory exhibits immense potential for effective solving of the uncertainty in the problem. Fuzzy set theory is an excellent mathematical tool to handle the uncertainty arising due to vagueness. Understanding human speech and recognizing handwritten characters are some common instances where fuzziness manifests. Fuzzy set theory is an extension of classical set theory where elements have varying degrees of membership. Fuzzy logic uses the whole interval between 0 and 1 to describe human reasoning. In FLC the input variables are mapped by sets of membership functions and these are called as “FUZZY SETS”.

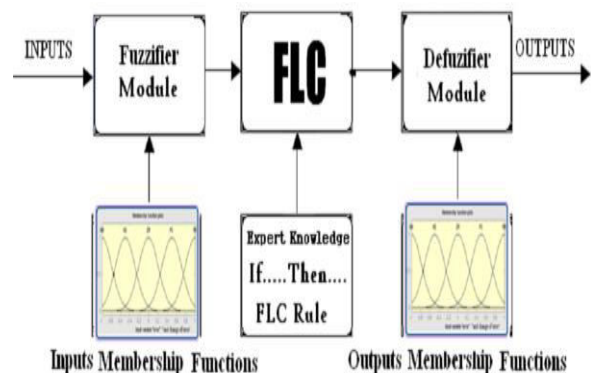

Fig.8. Fuzzy Basic Module

Fuzzy set comprises from a membership function which could be defines by parameters. The value between 0 and 1 reveals a degree of membership to the fuzzy set. The process of converting the crisp input to a fuzzy value is called as “fuzzification.” The output of the Fuzzier module is interfaced with the rules. The basic operation of FLC is constructed from fuzzy control rules utilizing the values of fuzzy sets in general for the error and the change of error and control action.

The results are combined to give a crisp output controlling the output variable and this process is called as “DEFUZZIFICATION.”

TABLE I : FUZZY REULES

Control		e	Δe	NL	NM	NS	ZR	PS	PM	PL
NL	NL	NL	NL	NL	NL	NL	NL	NL	NL	NL
NM	NL	NL	NM	NM	NS	NS	NS	NS	NS	NS
NS	NL	NM	NM	NS	NS	NS	ZR	ZR	ZR	ZR
ZR	ZR	ZR	ZR	ZR	ZR	ZR	ZR	ZR	ZR	ZR
PS	ZR	PS	PS	PS	PM	PM	PM	PM	PL	PL
PM	PS	PS	PS	PM	PM	PL	PL	PL	PL	PL
PL	PL	PL	PL	PL	PL	PL	PL	PL	PL	PL

VII. HYBRID FUZZY CONTROLLER

The hybrid fuzzy controller designed to control the outlet temperature of shell and tube heat exchanger system. Figure 4.6 shows the parallel form of PID controller where all the elements(proportional, integral and derivative) are summed together to produce the control effect.

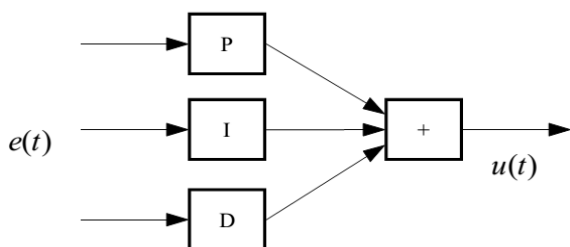

Fig.9. Parallel form of PID controller

The conventional design of PID controller was some what modified and a new hybrid fuzzy PID controller was designed. Instead of

summation effect a Mamdani based fuzzy inference system is implemented. The inputs to the mamdani based fuzzy inference system are error and change in error. Figure 3.8 shows the fuzzy inference system developed for hybrid fuzzy controller.

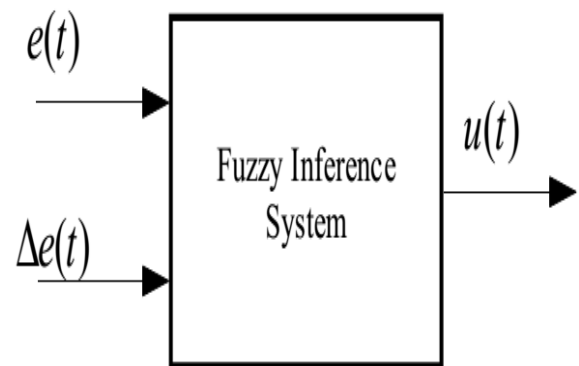

Fig.10. Mamdani based fuzzy inference system

Figure.11 shows the structure of hybrid fuzzy logic controller, which keeps the general architecture of PID controller as shown in figure 4.6 with some slight modifications. A mamdani based fuzzy inference system is implemented in between proportional and derivative term. The integral term is then added to the output of fuzzy inference system.

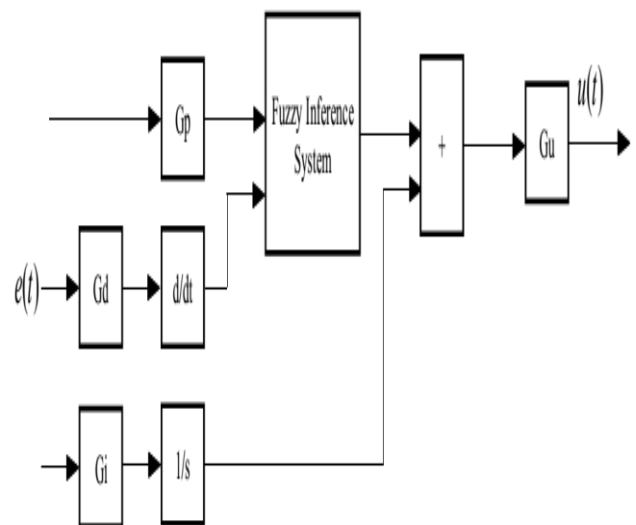

Fig.11. Structure of hybrid fuzzy controller

VIII. MATLAB/SIMULATION RESULTS

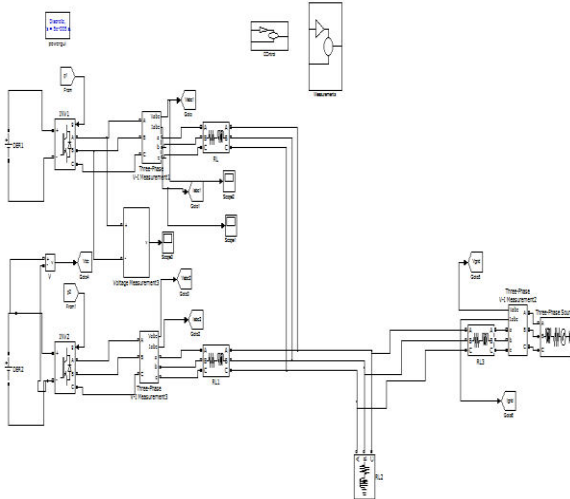

Fig.12. Matlab and Simulink Circuit diagram for GTM

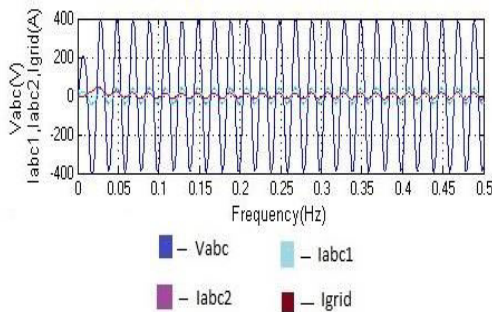

Fig.13. Simulation results for GTM:Phase voltages (Vabc), Phase currents (Iabc1, Iabc2) and Grid current (Igrid)

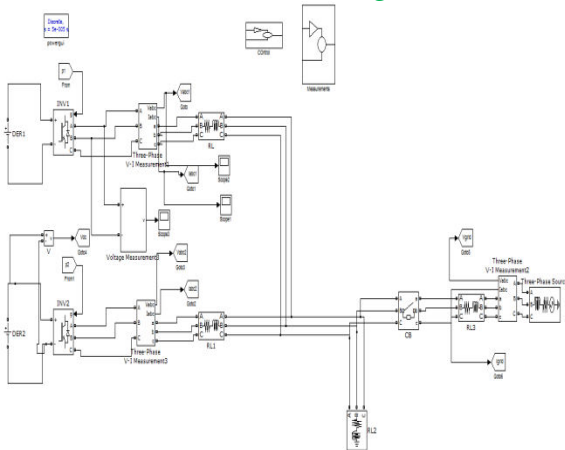

Fig.14. Matlab and Simulink circuit for grid-tracking in ILM

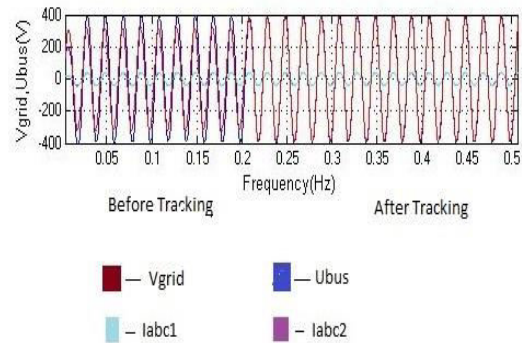

Fig.15. Simulation results for grid-tracking in ILM : Phase voltages (Vabc), Phase currents (Iabc1, Iabc2) and Grid current (Igrid)

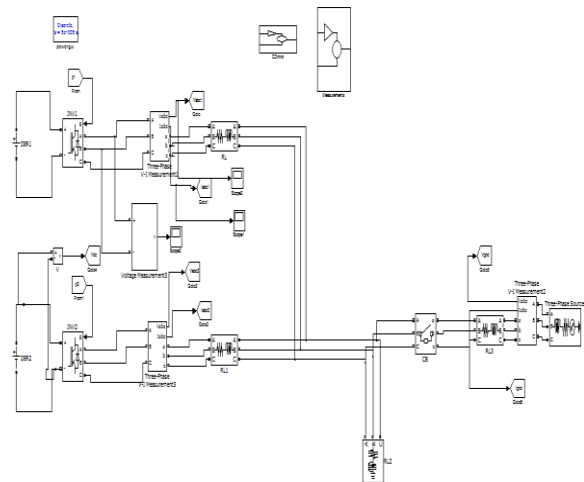

Fig.16. Matlab and Simulink circuit for mode transfer from ILM to GTM

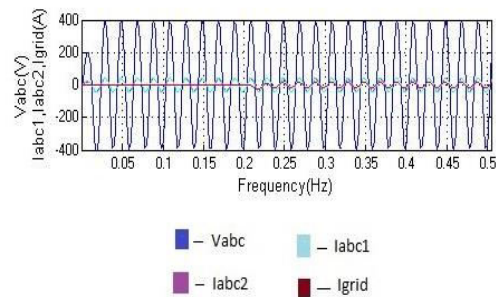

Fig.17. Simulation results for mode transfer from ILM to GTM: Phase voltages (Vabc), Phase currents (Iabc1, Iabc2) and Grid current (Igrid)

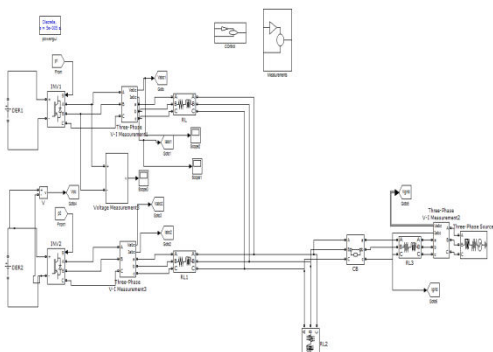

Fig.18. Matlab and Simulink circuit for mode transfer from GTM to ILM

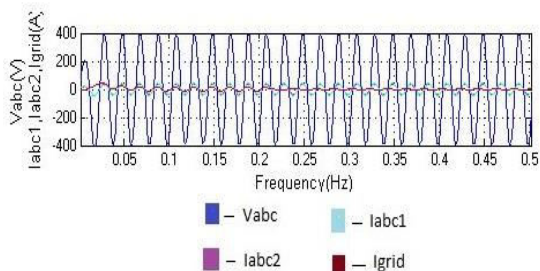

Fig.19. Simulation results for mode transfer from GTM to ILM: Phase voltages (Vabc), Phase currents (Iabc1, Iabc2) and Grid current (Igrid)

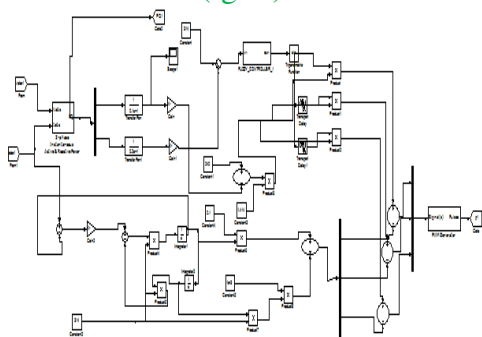

Fig.20. Matlab and Simulink Control circuit for fuzzy logic controller

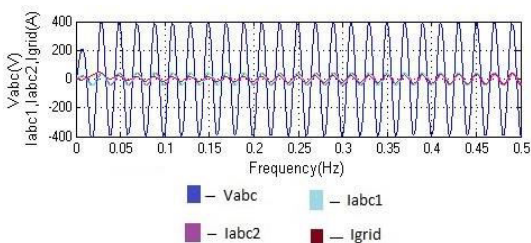

Fig.21. Simulation waveform of GTM with Fuzzy logic controller

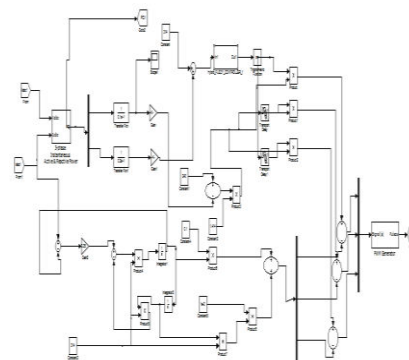

Fig.22. Matlab and Simulink Control circuit for GTM with Hybrid Fuzzy logic controller

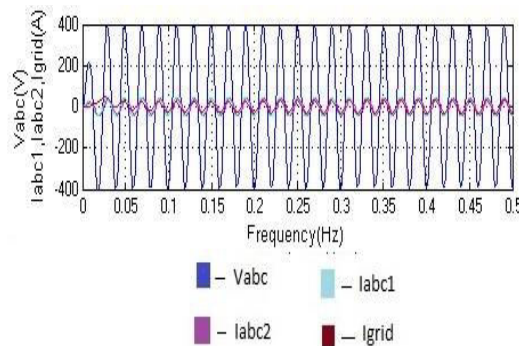
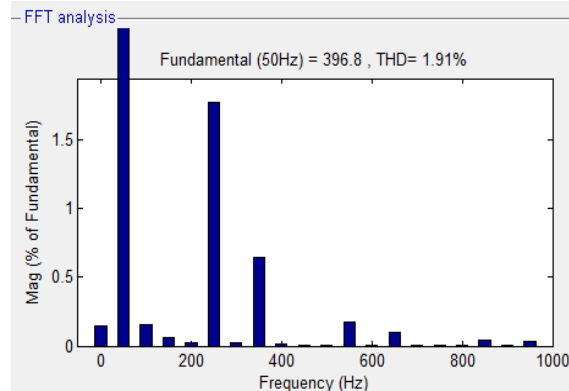
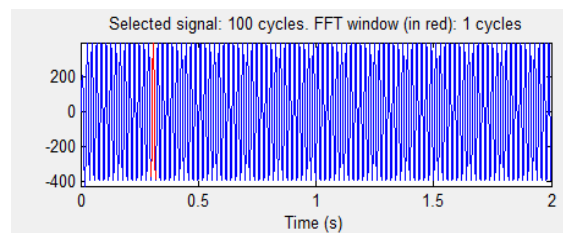
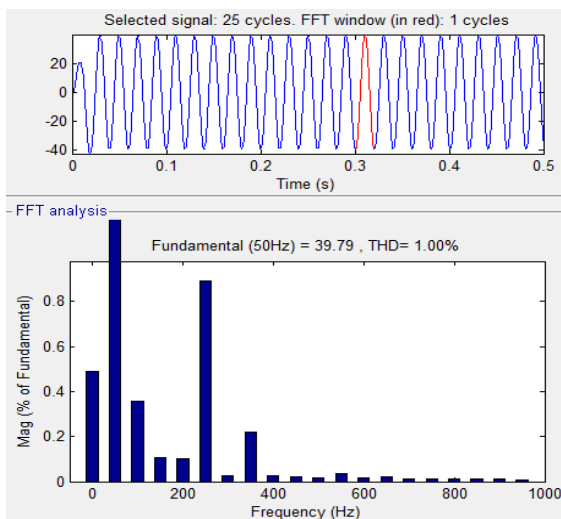

Fig.23. Simulation waveform of GTM with Hybrid Fuzzy Logic controller



(a) PI Controller



(b) Fuzzy logic controller

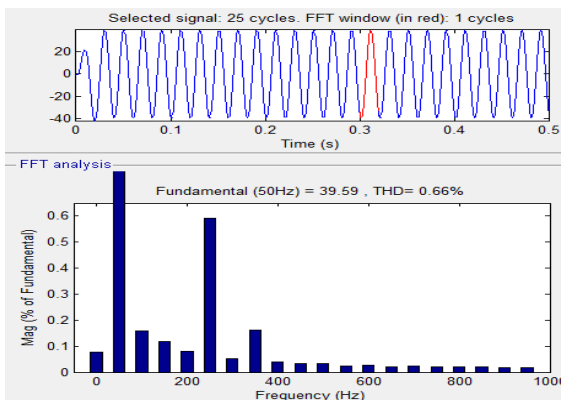

(c) Hybrid fuzzy logic controller

Fig.24. THD waveforms for the GTM with PI, Fuzzy and Hybrid fuzzy controller

IX. CONCLUSION

In this project a complete control system of smart microgrid is proposed in this project, in order to realize the seamless mode transfer of the GTM and ILM. In the system, every DG unit will work as the voltage source and use the same control method of output voltage, whatever in GTM or ILM. The only difference of GTM and ILM is how to regulate of the reference voltage of the voltage source control. Therefore, this control system can easily realize the seamless mode transfer of the control methods between the GTM and ILM, and avoids the vibration and distortion of AC

bus voltage simultaneously. The proposed GTM is further implemented with fuzzy and Hybrid fuzzy controllers. By using these controllers connected to GTM is compared and attained good results in case of THD is reduced and better results obtained for seamless mode transfer.

REFERENCES

- [1] D. Prasad rao, A. Ravi Kumar and T. GiriBabu, "Enhancement of Microgrid Control In Distribution System Using Fuzzy Logic Technique," International Journal of Advanced Technology in Engineering and Science, Vol. No.4, Issue No. 09, September 2016.
- [2] SolankeTirupati U, Kulkarni Anant A, "Effective Microgrid Synchronization in Islanded Mode: Controlled Input/output PI-Fuzzy-PI Algorithm," International Journal of Computer Applications (0975 – 8887) Volume 75 – No.16, August 2013.
- [3] Peng, F.Z., Yun Wei Li, Tolbert, L.M., "Control and protection of power electronics interfaced distributed generation systems in a customer driven microgrid," Power & Energy Society General Meeting, 2009. PES '09.IEEE , pp.1-8, 26-30 July 2009
- [4] Zhilei Yao, Lan Xiao, Yangguang Yan, "Seamless Transfer of SinglePhase Grid-Interactive Inverters Between Grid-Connected and StandAlone Modes," Power Electronics, IEEE Transactions on , vol.25, no.6, pp.1597-1603, June 2010
- [5] J.M. Guerrero, Loh P C, Tzung-Lin Lee, MukulChandorkar, "Advanced control architectures for intelligent microgrids—Part II: Power quality, energy storage, and AC/DC microgrids," Industrial Electronics, IEEE Transactions on, 2013, 60(4): 1263-1270.
- [6] Mingzhi Gao, Canhui Zhang, MaohangQiu, Weiheng Li, Min Chen, Zhaoming Qian, "An accurate power-sharing control method based on circulating-current power model for voltage-source-inverter parallel system," 2015 IEEE APEC, pp.1815-1821, 15-19 March 2015



International Journal for Innovative Engineering and Management Research

A Peer Reviewed Open Access International Journal

www.ijemr.org

- [7] Yunwei Li, D.M. Vilathgamuwa, Poh Chiang Loh, "Design, analysis, and real-time testing of a controller for multibusmicrogrid system," *Power Electronics, IEEE Transactions on*, vol.19, no.5, pp.1195-1204, Sept. 2004
- [8] Yang Fu, Lisha Huang, Jingjing Zhao, "Micro-Grid Seamless Switchover Method Based on Controller State Following," *Journal of Power and Energy Engineering*, 2015, 3, 128-135.