



International Journal for Innovative Engineering and Management Research

A Peer Reviewed Open Access International Journal

www.ijiemr.org

COPY RIGHT

2017 IJIEMR. Personal use of this material is permitted. Permission from IJIEMR must be obtained for all other uses, in any current or future media, including reprinting/republishing this material for advertising or promotional purposes, creating new collective works, for resale or redistribution to servers or lists, or reuse of any copyrighted component of this work in other works. No Reprint should be done to this paper, all copy right is authenticated to Paper Authors

IJIEMR Transactions, online available on 12th Dec 2017. Link

[:http://www.ijiemr.org/downloads.php?vol=Volume-6&issue=ISSUE-12](http://www.ijiemr.org/downloads.php?vol=Volume-6&issue=ISSUE-12)

Title: **DUAL BUCK INVERTER WITH SERIES CONNECTED DIODES AND SINGLE INDUCTOR**

Volume 06, Issue 12, Pages: 414–422.

Paper Authors

D.PRASADA RAO, S.PRIYANKA

Ellenki Engineering College, patelguda; sangareddy (Dt); Telangana, India.



USE THIS BARCODE TO ACCESS YOUR ONLINE PAPER

To Secure Your Paper As Per **UGC Guidelines** We Are Providing A Electronic Bar Code

DUAL BUCK INVERTER WITH SERIES CONNECTED DIODES AND SINGLE INDUCTOR

¹D.PRASADA RAO, ²S.PRIYANKA

¹Assistant Professor, Dept of E.E.E, Ellenki Engineering College, patelguda; sangareddy (Dt); Telangana, India

²M-tech Scholar, Dept of E.E.E, Ellenki Engineering College, patelguda; sangareddy (Dt); Telangana, India

Abstract- This invention relates to a dual buck converter used to reduce an unregulated high input voltage without a ground reference to a regulated output voltage. This is accomplished by coupling the inductors of two independent buck converters. The input voltage is split across the dual buck converter and the midpoint is balanced by coupling the inductors and switching the two switches at the same time. The inductors are wound on a single core, with the windings magnetically coupled, to form a new coupled inductor. A low cost, multiple output buck converter is provided using a single inductor, a single pulse width modulator integrated circuit, and two MOSFETs plus one additional MOSFET and capacitor for each voltage output. A kind of novel dual buck inverter with series connected diodes and single inductor is introduced. The novel inverter retains the dual buck topologies' advantage of high reliability and can make full use of the inductance. In order to improve the magnetic utilization of the dual buck inverter, a kind of single inductor dual buck topology was proposed in. Compared with the traditional full bridge inverter, two extra switches are applied in the proposed topology. The novel topology has the following advantages: firstly, retains the advantages of the traditional dual buck inverters, secondly, makes full use of the inductance, thirdly, the proposed inverter saves two switches compared to the traditional single inductor topology, which makes a lower conducting loss and a simpler controlling strategy. In this project additional fuel cell is integrated with PV system to increase the generation capability.

I INTRODUCTION

The fast development of the clean energy power generation requires the inversion system, especially the inverters, to be more and more reliable. Yet shoot through problem of the power devices is a Major threaten to the reliability. As is known, a traditional method to solve the shoot through issue is by setting dead time. However, the dead time will cause a distortion of the output current. Also, during the dead time, the current may flow through the body diode of the switch which can cause

the failure of the reverse recovery [1]. For the purpose of solving the above problems, the dual buck topologies are proposed in a lot of research. By combining two unidirectional buck circuits, the dual buck inverters will not suffer the threaten of shoot through problem and the freewheeling current will flow through the independent diodes which can solve the reverse recovery problem of the MOSFET's body diodes. However, the major drawback of the dual buck topologies is the magnetic utilization. Only half of the

inductance is used in every working mode. And it will obviously increase the weight and volume of the system [2]. In order to improve the magnetic utilization of the dual buck inverter, a kind of single inductor dual buck topology was proposed in [5]. Compared with the traditional full bridge inverter, two extra switches are applied in the proposed topology. The single inductor topology can make full use of the inductance, but the conducting loss is largely increased because four switches are flown through during the power delivering modes. This paper proposed a kind of novel phase leg topology with series connected diodes and single inductor to highly improve the reliability of the inverter, especially for the MOSFET inverter [6]. Applying the phase leg to the single phase inverter, an improved single inductor dual buck inverters are proposed in this paper. The novel topology has the following advantages: firstly, retains the advantages of the traditional dual buck inverters, secondly, makes full use of the inductance, thirdly, the proposed inverter saves two switches compared to the traditional single inductor topology, which makes a lower conducting loss and a simpler controlling strategy. The simulation and experimental results have verified the analysis.

II TRADITIONAL DUAL BUCK TOPOLOGIES

Fig.1 shows the traditional dual buck and dual boost inverters [7]. The most attractive advantage of the dual buck topologies is the high reliability. Firstly, without adding the extra dead time, the dual buck topologies can solve the shoot through problem. Secondly, compared to the traditional H-bridge inverter, the current will not flow through the body

diodes of the switches in the dual buck topologies which means no reverse recovery problem exists in the MOSFET phase legs. Considering the above two aspects, the dual buck topologies can achieve high reliability without the shoot through and reverse recovery issues.

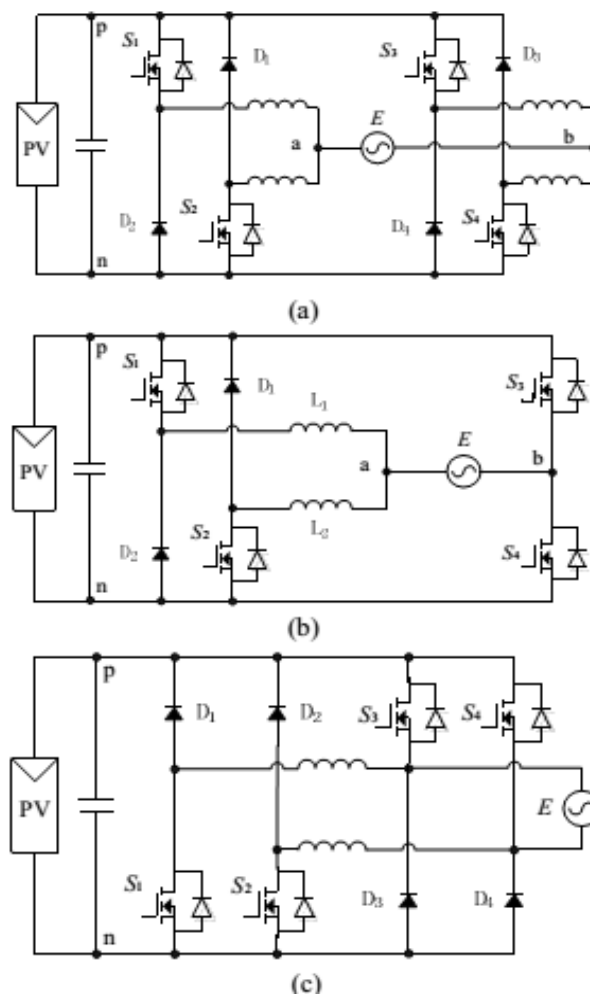

Fig.1. Traditional Dual buck and dual boost full bridge inverters.

However, the main drawback of the dual buck topologies is the low magnetic utilization. In each power delivering and freewheeling modes, the current only flow through half of the inductance, which means the other half of the inductance, is wasted in each working condition. The low utilization of the inductance makes the increasing

of the weight and volume for the whole system. To solve this problem, a concept of single inductor dual buck full bridge inverter [5] is proposed. Fig.2 shows the single inductor topology. The novel topology includes six switches and two diodes. Comparing to the traditional dual buck full bridge inverter, the single inductor topology can save half of the inductance. And the novel topology retains the original advantages of high reliability. Also, there is no need to add the dead time in the high frequency unipolar switching strategy. The inductance can be fully utilized in the single inductor inverter. However, a high level of conduction loss is the main drawback of the novel topology. During the power delivering mode, the current flows through four switches which is a lot more than the traditional full bridge inverters. Besides, compared to the traditional H-bridge inverters, the extra two switches make controlling strategy more complex. And in the dual buck single inductor inverter, the current will flow through the body diodes of the series MOSFET switches which can cause the problem of reverse recovery.

To solve the problem of traditional H-bridge inverter, including the shoot through issue and the reverse recovery of the MOSFET, a kind of dual buck inverter with series connected diodes and single inductor is proposed in this paper. The newly proposed topology retains the advantage of traditional dual buck inverter and solves the problem of low magnetic utilization. Also, the proposed topologies will not invite extra switches which means a simpler controlling strategy compared to the traditional dual buck single inductor full bridge inverter in [5].

III HIGHLY RELIABLE MOSFET INVERTER WITH SINGLE INDUCTOR

This section proposes a kind of novel MOSFET phase leg which maintains the high reliability of the dual buck topology and also makes full use of the dual buck's inductance. Fig.3 shows the traditional dual buck phase leg and the proposed novel MOSFET phase leg. The two inductors in Fig.3 (a) are replaced by two diodes and one inductor just as shown in Fig.3 (b). Applying the proposed phase leg to the full bridge inverter, a novel dual buck MOSFET inverter with series connected diodes and single inductor is proposed then. The novel dual buck inverter is shown in Fig.4. Compared to the traditional single inductor dual buck inverter in Fig.2, the proposed topologies save two switches which mean a simpler control strategy. Meanwhile, in the power delivering mode, the current of the novel topology only flows through one switch and two diodes which is less than the traditional one in Fig.2.

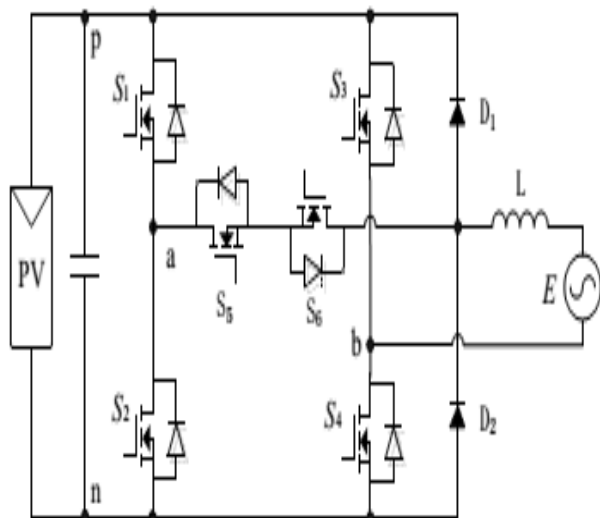

Fig.2. Traditional Dual buck full bridge inverter with single inductor.

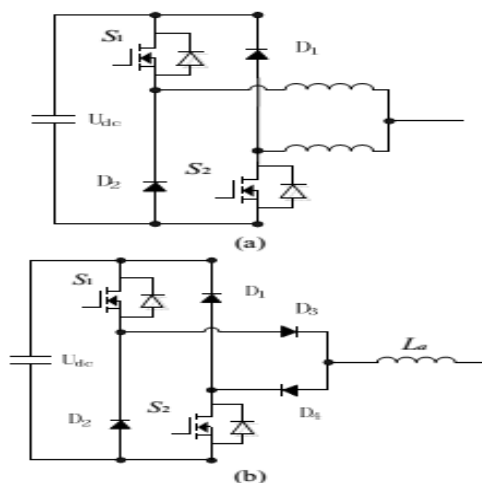

Fig.3. (a) Traditional dual buck phase leg (b) proposed dual buck phase legs with series connected diodes and single inductor.

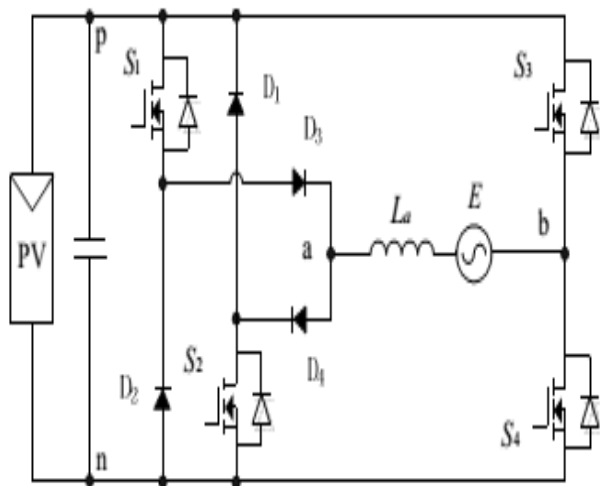

Fig.4. Proposed dual buck full bridge inverters with single inductor.

So, the proposed single inductor dual buck topologies have the advantages in the aspect of efficiency, control complexity and system cost and size. The operational principle of proposed single inductor dual buck inverter can be illustrated with four operation modes. Fig.5 shows the specific current flow paths during the energy transferring modes and the freewheeling modes. A unipolar SPWM strategy is applied to control the four switches of the novel inverter.

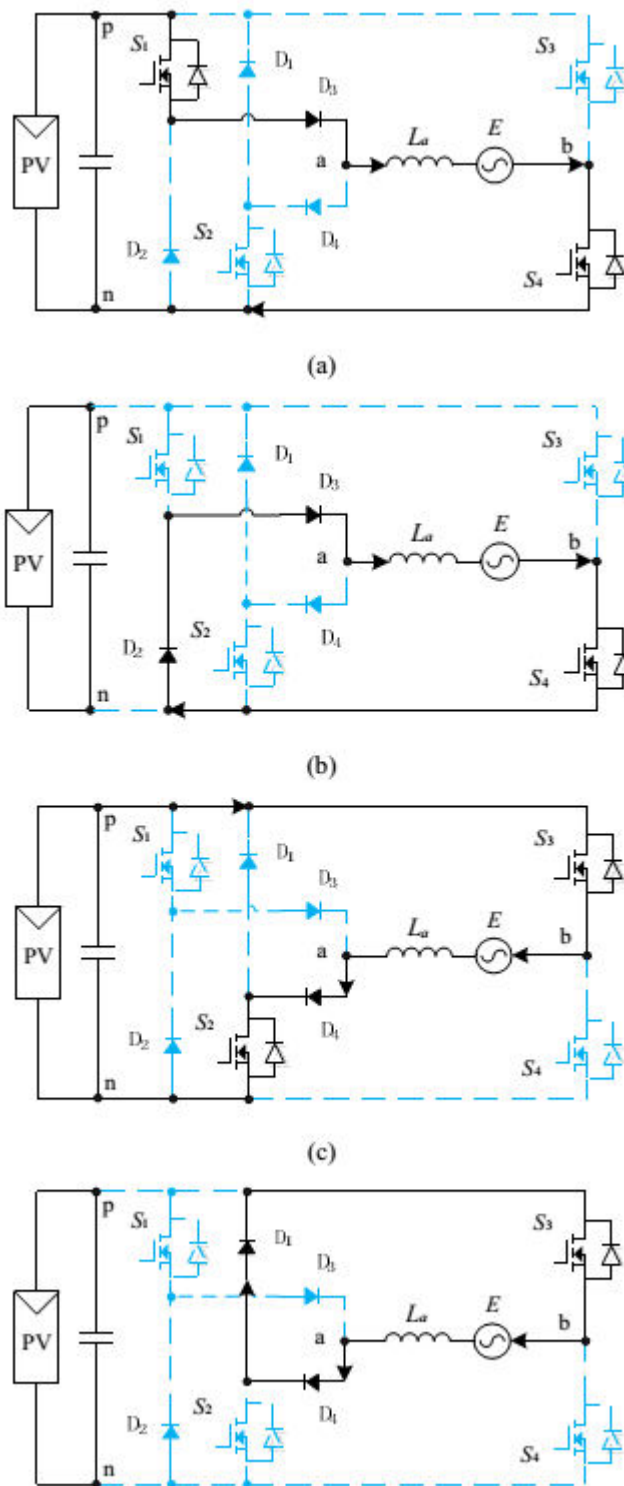

Fig.5. Four working modes of the proposed dual buck full bridge inverter with single inductor in Fig.3.4.

1 Operational Principle of the Proposed Inverter

Mode 1: During positive half period, S_1 is modulated in high frequency, while S_4 is always ON. When S_1 and S_4 are on, the current flows through S_1 , D_3 , grid and S_4 successively.

Mode 2: When S_1 is off, the current flows through D_2 , D_3 , grid and S_4 successively. As shown in Fig.5 (b), in this freewheeling mode, the diode D_4 prevents the current from flowing through the body diode of S_2 , which avoid the failure of the MOSFET's reverse recovery.

Mode 3: During negative half period, S_2 is modulated in high frequency, while S_3 is always ON. When S_2 and S_3 are on, the current flows through S_3 , grid, D_4 and S_2 successively.

Mode 4: When S_2 is off, the current flows through S_3 , grid, D_4 and D_1 successively. As shown in Fig.5 (d), in this freewheeling mode, the diode D_3 prevents the current from flowing through the body diode of S_1 , which can also avoid the failure of the MOSFET's reverse recovery. The switching signals of the proposed inverter are shown in Fig.6. Without the extra two switches of the traditional dual buck single inductor inverter in Fig.2, the proposed dual buck topology with series connected diodes can achieve the high reliability. No dead time is needed in the high frequency of the switches. Thus, the distortion rate of the output current can be decreased.

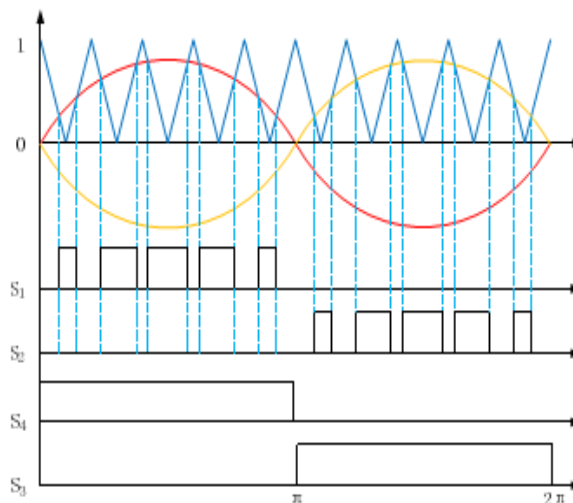

Fig.6. The switching signals of the proposed inverters.

2 Analysis of the Common-mode Characteristic

The transformerless photovoltaic (PV) grid-connected system is an important application for the single phase inverter. However, in a transformerless PV system, the fluctuation of the common mode voltage will excite leakage current in the common mode path which may cause the safety problems and distort the output current. The equivalent common mode circuit of the proposed inverter is shown in Fig.3.7. The red lines represent the flowing path of the leakage current. The value of the leakage current depends on the fluctuating frequency of the common-mode voltage, u_{Cpv} where the C_{pv} represents the equivalent stray capacitance of the PV panel. As is shown in Fig.3.7, in the positive grid period, the upper potential of C_{pv} is equal to the ground. So, the u_{Cpv} is zero in this situation. On the other hand, in the negative grid period, the potential of point p is equal to the ground. Thus, the upper potential of C_{pv} is lower than the ground by u_{dc} . In this situation, the u_{Cpv} is $-u_{dc}$. So, whether in the positive grid period or in the negative grid period, the voltage of the

PV stray capacitance, $u_{C_{pv}}$, is kept constant. The common-mode current i_{cm} is mainly induced by the fluctuation of u_{cm} as expressed in (3.1)

$$i_{cm} = C_{pv} \frac{du_{cm}}{dt} \quad (1)$$

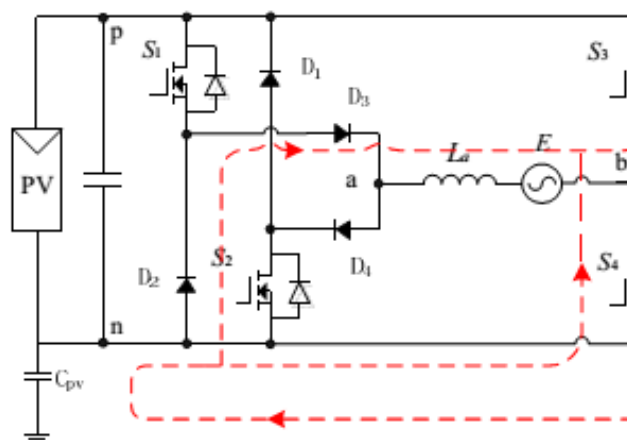

Fig.7. the equivalent common-mode circuit of the proposed single inductor dual buck inverter.

FUEL CELL OPERATION

Pressurized hydrogen gas (H_2) enters cell on anode side. Gas is forced through catalyst by pressure. When H_2 molecule comes contacts platinum catalyst, it splits into two H^+ ions and two electrons (e^-). Electrons are conducted through the anode. Make their way through the external circuit (doing useful work such as turning a motor) and return to the cathode side of the fuel cell. On the cathode side, oxygen gas (O_2) is forced through the catalyst Forms two oxygen atoms, each with a strong negative charge. Negative charge attracts the two H^+ ions through the membrane, Combine with an oxygen atom and two electrons from the external circuit to form a water molecule (H_2O). How a fuel cell works: In the polymer electrolyte membrane (PEM) fuel cell, also known as a proton-

exchange membrane cell, a catalyst in the anode separates hydrogen atoms into protons and electrons. The membrane in the center transports the protons to the cathode, leaving the electrons behind. The electrons flow through a circuit to the cathode, forming an electric current to do useful work. In the cathode, another catalyst helps the electrons, hydrogen nuclei and oxygen from the air recombine. When the input is pure hydrogen, the exhaust consists of water vapor. In fuel cells using hydrocarbon fuels the exhaust is water and carbon dioxide. Cornell's new research is aimed at finding lighter, cheaper and more efficient materials for the catalysts and membranes. A single fuel cell consists of an electrolyte sandwiched between two electrodes, an anode and a cathode. Bipolar plates on either side of the cell help distribute gases and serve as current collectors. In a Polymer Electrolyte Membrane (PEM) fuel cell, which is widely regarded as the most promising for light-duty transportation, hydrogen gas flows through channels to the anode, where a catalyst causes the hydrogen molecules to separate into protons and electrons. The membrane allows only the protons to pass through it. While the protons are conducted through the membrane to the other side of the cell, the stream of negatively-charged electrons follows an external circuit to the cathode. This flow of electrons is electricity that can be used to do work, such as power a motor. On the other side of the cell, air flows through channels to the cathode. When the electrons return from doing work, they react with oxygen in the air and the hydrogen protons (which have moved through the membrane) at the cathode to form water. This union is an exothermic reaction,

generating heat that can be used outside the fuel cell. Fuel cells directly convert the chemical energy in hydrogen to electricity, with pure water and potentially useful heat as the only byproducts. Hydrogen-powered fuel cells are not only pollution-free, but also can have more than two times the efficiency of traditional combustion technologies. The power produced by a fuel cell depends on several factors, including the fuel cell type, size, temperature at which it operates, and pressure at which gases are supplied. A single fuel cell produces barely enough voltage for even the smallest applications. To increase the voltage, individual fuel cells are combined in series to form a stack. (The term “fuel cell” is often used to refer to the entire stack, as well as to the individual cell.) Depending on the application, a fuel cell stack may contain only a few or as many as hundreds of individual cells layered together.

IV SIMULATION RESULTS

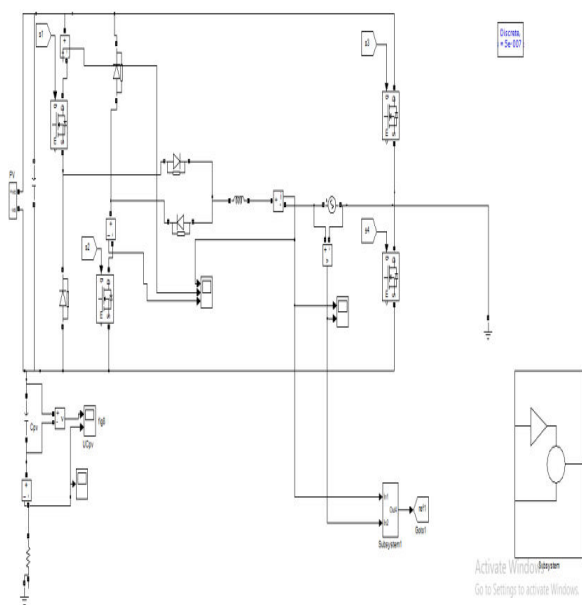

Fig 1: Simulation modeling of dual buck full bridge inverters with single inductor

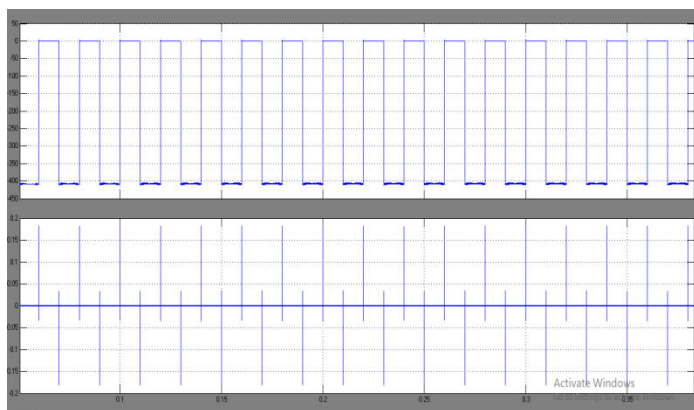

Fig 2: Simulation waveforms of leakage voltage and leakage current

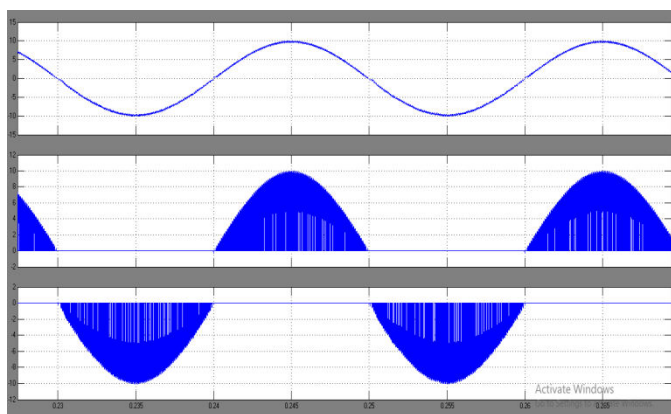

Fig 3: Simulation Waveforms of filtering current and the switching current

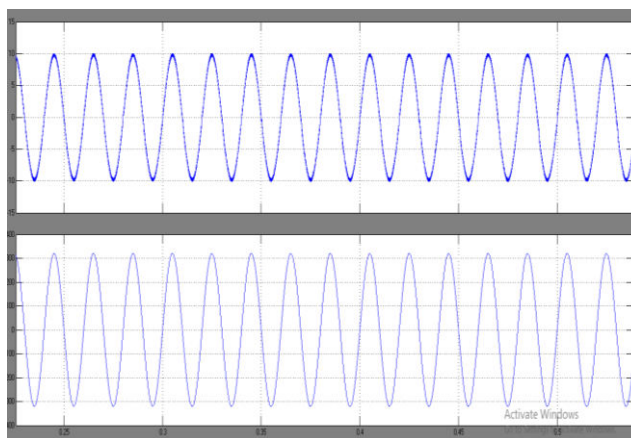

Fig 4: Simulation Waveforms of sourceCurrent and Voltage

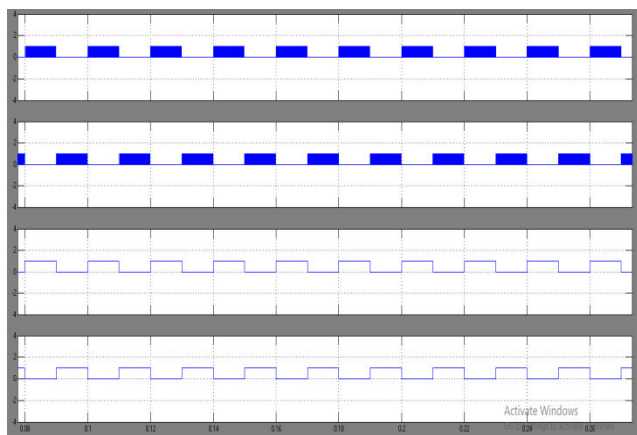

Fig 5: The simulated switching signals or pulses of the dual buck inverters.

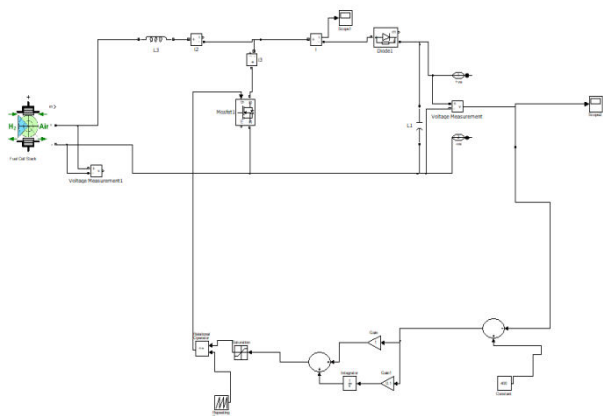

Fig 6: Simulation modeling of Fuel cell Circuit

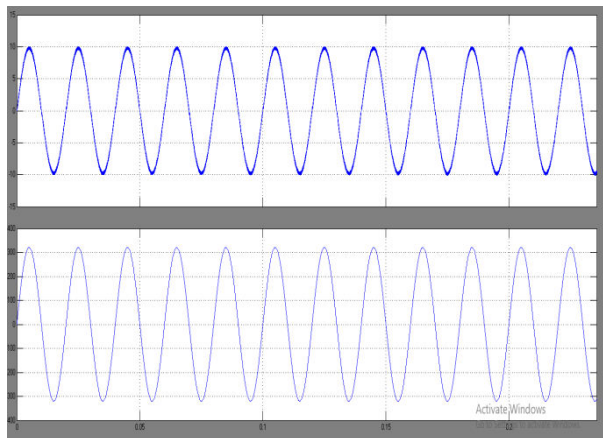

Fig 7: Simulation Waveforms of Fuel cell source Current and Voltage

V CONCLUSION

This paper reviews the already published dual buck topologies. The advantages and disadvantages of the dual buck inverters are specifically analyzed. In order to solve the main drawback of low magnetic utilization, a kind of phase leg topology is proposed. By applying the novel phase leg to the full bridge inverter, the new topology maintains the high reliability of the traditional dual buck inverter and the magnetic utilization is largely improved. Also, compared to the traditional single inductor dual buck inverter, the novel topology has the advantages in conducting loss and controlling complexity. The simulation and experimental results verified the performance of proposed inverter.

REFERENCES

- [1] T. Kerekes, R. Teodorescu, P. Rodriguez, G. Vazquez, E. Aldabas, "A new high-efficiency single-phase transformer less PV inverter topology," *IEEE Trans. Ind. Electron.*, vol. 58, no. 1, pp. 184-191, Jan. 2011.
- [2] Zhu, Chenghua, Fanghua Zhang, and Yangguang Yan, "A novel split phase dual buck half bridge inverter", in *Proc. 20th IEEE Applied Power Electronics Conference and Exposition*, 2005, vol.2, pp.845-849.
- [3] Hong Feng, Ying Pei-pe, Wang Cheng-hua, "Decoupling Control of Input Voltage Balance for Diode-Clamped Dual Buck Three Level Inverter", in *Proc. 28th Annual IEEE Applied Power Electronics Conference and Exposition*, Long Beach, California, USA, March 17-21, 2013, pp.482-488.
- [4] Liu Miao, Hong Feng, Wang Cheng-hua. A Novel Flying-Capacitor Dual Buck Three-

Level Inverter [C], in Proc. 28th Annual IEEE Applied Power Electronics Conference and Exposition, Long Beach, California, USA, March 17-21, 2013, pp.502-506.

[5] Hong Feng, Liu Jun, Ji Baojian, Zhou Yufei, and Wang Jianhua, “Single Inductor Dual Buck Full-Bridge Inverter”, IEEE Trans. Ind. Electron., vol. 62, no. 8, pp. 4869–4877, Aug 2015.

[6] B. F. Chen, B. Gu, L. H. Zhang, Z. U. Zahid, Z. L. Liao, J.-S. Lai, Z. L. Liao and R. X. Hao, “A High Efficiency MOSFET Transformerless Inverter for No-isolated Micro-inverter Application,” IEEE Trans. Power Electron., vol. 30, no. 7, pp. 3610–3622, July. 2015.

[7] B. F. Chen, P. W. Sun, C. Liu, C-L. Chen, J.-S. Lai, and W. Yu, “High efficiency transformer less photovoltaic inverter with wide-range power factor capability”, in Proc. of IEEE 27th Applied Power Electronics Conference and Exposition, Orlando, FL, Feb. 2012.

[8] B. Gu, J. Dominic, J.-S. Lai, C-L. Chen, T. LaBella, and B. F. Chen, “High Reliability and Efficiency Single-Phase Transformerless Inverter for Grid-Connected Photovoltaic Systems,” IEEE Trans. Power Electron, vol.28, no. 5, pp.2235-2245. May, 2013.

[9] T. Kerekes, R. Teodorescu, P. Rodriguez, G. Vazquez, and E. Aldabas, “A new high-efficiency single-phase transformer less PV inverter topology,” IEEE Trans. Ind. Electron., vol. 58, no. 1, pp. 184–191, Jan. 2011.