



International Journal for Innovative Engineering and Management Research

A Peer Reviewed Open Access International Journal

www.ijiemr.org

COPY RIGHT



ELSEVIER
SSRN

2022IJIEMR. Personal use of this material is permitted. Permission from IJIEMR must be obtained for all other uses, in any current or future media, including reprinting/republishing this material for advertising or promotional purposes, creating new collective works, for resale or redistribution to servers or lists, or reuse of any copyrighted component of this work in other works. No Reprint should be done to this paper, all copy right is authenticated to Paper Authors

IJIEMR Transactions, online available on 28th Dec 2022. Link

[:http://www.ijiemr.org/downloads.php?vol=Volume-11&issue=ISSUE-12](http://www.ijiemr.org/downloads.php?vol=Volume-11&issue=ISSUE-12)

DOI: 10.48047/IJIEMR/V11/ISSUE 12/72

Title **DESIGN AND MODELING OF MICROGRID WITH INTEGRATION OF MULTIPLE RENEWABLE ENERGY SOURCES**

Volume 11, Issue 12, Pages: 588-593

Paper Authors:

Dr. J. Ranga, Dr. K R Vadivelu, Mr. B. Ashok Kumar, Mr. V Indra Teja, Dr. S. S. Sarma



USE THIS BARCODE TO ACCESS YOUR ONLINE PAPER

To Secure Your Paper As Per **UGC Guidelines** We Are Providing A Electronic Bar Code

DESIGN AND MODELING OF MICROGRID WITH INTEGRATION OF MULTIPLE RENEWABLE ENERGY SOURCES

Dr. J. Ranga, Professor, EEE Department, Ramachandra College of Engineering, Eluru

Dr. K R Vadivelu, Professor, EEE Department, Ramachandra College of Engineering, Eluru

Mr. B. Ashok Kumar, Associate Professor, EEE Department, Ramachandra College of Engineering, Eluru

Mr. V Indra Teja, Assistant Professor, EEE Department, Ramachandra College of Engineering, Eluru

Dr. S. S. Sarma, Associate Professor, EEE Department, Ramachandra College of Engineering, Eluru

Abstract

This paper presents the design of a control strategy for a direct current micro-grid (DCMG) for integrating various renewable energy sources. The use of renewable resources like the solar energy and various other clean sources of energy has been on an increase in demand in the recent years due to their ease in availability and low and cost. This paper demonstrates how to use the solar energy, wind energy and the kinetic energy from footsteps of people walking over piezo based footboard. The Solar Panel is used to harness the solar power. It converts the solar power into voltage, which when more than the voltage in the battery is able to charge the battery. The power available through the solar panel is sensed by an Atmega family microcontroller which it displays on the LCD. The power available through the wind turbine is measured by an Atmega family microcontroller which it displays on the LCD. Similarly, the power generated through footsteps over Piezo Footboard is shown on the LCD. In this case, the footstep count is also displayed on the LCD along with the voltage generated by that particular footstep. In this way one can charge the battery through solar, wind and footstep energies while simultaneously also monitoring of how much is getting generated with the use of Hybrid Power generating System.

Keywords—DC Micro grid, ATmega, Renewable energy sources, MATLAB, Simulink

1. INTRODUCTION :

Energy is essential to everyone's life no matter when and where they are. This is especially true in this new century, where people keep pursuing

higher quality of life. Among different types of energy, electric energy is one of the most important that people need every day. It is now a globally accepted reality that electrical energy is fundamental for social and economic development. Unfortunately still one third of the world's population lives in developing and threshold countries and have no access to electricity. The statistic shows that the population growth is mostly in developing countries where most of the people live in remote and rural areas. So, to supply the electricity requirements for them, the extension of utility grid is complicated and expensive due to geographical, economical and social barriers. Up to now, mostly diesel generator sets are used for rural electrification. This is not a good solution since, the fuel, maintenance cost is expensive, and it is also not environment friendly. Multi-source alternative energy systems with proper control have great potential to provide higher quality and more reliable power to customers than a system based on a single resource. However, the issues on optimal system configuration, proper power electronic interfaces and power management among different energy sources are not resolved yet. Therefore, more research work is needed on new alternative energy systems and their corresponding control strategies. Renewable energy is any natural source that can replenish itself naturally over a short amount of time, unlike the fossil fuels that are likely to run out in years to come. Recent research and development of renewable energy sources have shown excellent potential as a form of contribution to conventional power generation system. Renewable energy comes from many commonly known sources such as solar power, wind, running water, geothermal energy, piezo crystals and atmospheric fuels like hydrogen, etc., .

2. PROPOSED METHODOLOGY

Combining several different types of power sources will form a system, which is known as "Hybrid Power System". HPS combines two or more energy conversion devices, or two or more fuels for the same device, that when integrated, overcome limitations inherent in either. HPS is available in two modes; namely islanding and grid connected modes. In general, a hybrid power system might contain AC diesel generators-diesel system, an AC or DC distribution system, renewable power sources, energy storage, power converters, dump loads, load management options, or a supervisory

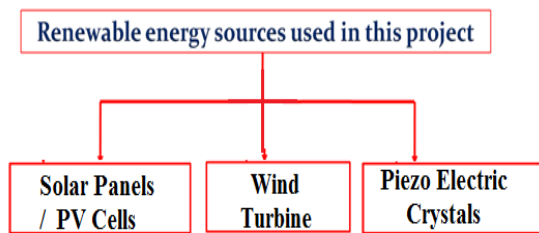

Figure 2.1 Different renewable energy sources used in the proposed HPS

The proposed HPS in this thesis focuses on the combination of renewable energy sources as shown in Figure 2.1, such as Photovoltaic cells, Piezo electric crystals and Batteries. These are clean and abundantly available in nature, offers many advantages over conventional coal based power system, such as low pollution, high efficiency, diversity of fuels, reusability of exhausts, and onsite installation.

2.1 IMPLEMENTATION

A. Solar panel/pv panel: Photovoltaic (PV) cells are made of special materials called semiconductors such as silicon, which is currently the most commonly used. Basically, when light strikes the cell, a certain portion of it is absorbed within the semiconductor material. This means that the energy of the absorbed light is transferred to the semiconductor.

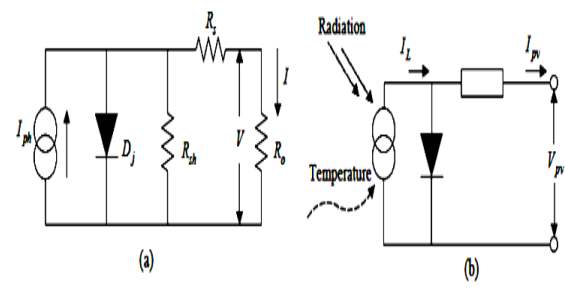

Figure 2.2 Solar cell (a) equivalent circuit (b) simplified circuit

Photovoltaic/solar cell is the device which converts sunlight into electricity directly of which magnitude of current and voltage depends on many factors like temperature, solar radiation, and wave length of incident photon etc. the solar cell produces DC supply.

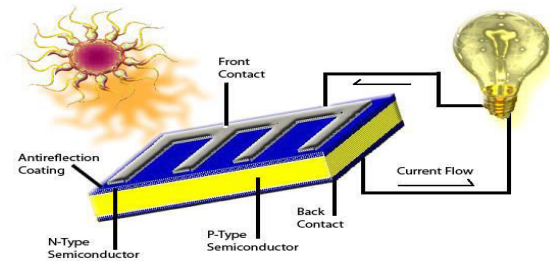

Fig 2.3 Concept of PV generating system

The diode represents the p-n junction of a solar cell. The temperature dependence of the diode saturation current and constant diode ideality factor are included in the modeling. At real solar cells, a voltage loss on the way to the external contacts is observed. This voltage loss is expressed by a series resistance (R_s). Furthermore leakage currents are described by a parallel resistance (R_{sh}). However, the series resistance is very small and the parallel resistance is very large. So we can ignore R_s and R_{sh} . The solar cell simplified circuit is shown in Figure.2.2 The typical PV characteristics are shown in Figure 2.3

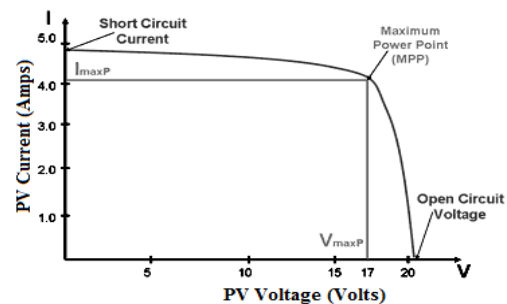

Figure 2.4 PV array V-I characteristics

Maximum-power point tracking: The maximum power point of a photovoltaic varies with incident illumination. For systems large enough to justify the extra expense, a maximum power point tracker tracks the instantaneous power by continually measuring the voltage and current (and hence, power transfer), and uses this information to dynamically adjust the load so the maximum power is always transferred, regardless of the variation in lighting

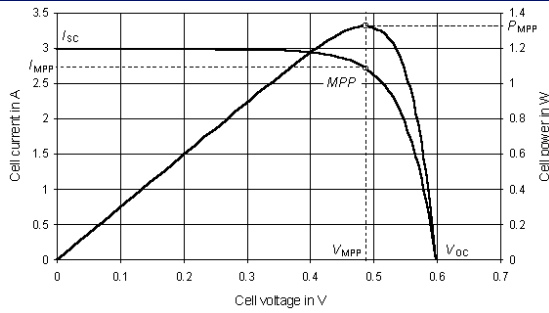

Figure 2.5 P-V/I characteristic of solar panel with MPPT

B. Wind Energy : Wind energy describes the process by which wind is used to generate electricity. Wind turbines convert the kinetic energy in the wind into mechanical power. A generator can convert mechanical power into electricity.

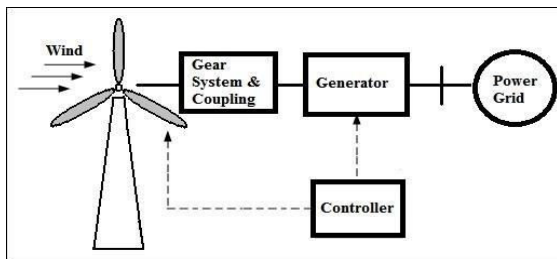

Fig:2.4 wind turbine

Turbine Blade The blade is the most distinctive and visible component of a wind turbine. It is also responsible for carrying out one of the most essential tasks of the energy conversion process: transforming the wind kinetic energy into rotational mechanical energy. Blades have greatly evolved in aerodynamic design and materials from the early windmill blades made of wood and cloth.

Gear Box : The rotor of a large three-blade wind turbine usually operates in a speed range from 6-20 rpm. This is much slower than a standard 4- or 6-pole wind generator with a rated speed of 1500 or 1000 rpm for a 50 Hz stator frequency and 1800 or 1200 rpm for a 60 Hz stator frequency. Therefore, a gearbox is necessary to adapt the low speed of the turbine rotor to the high speed of the generator.

The gearbox conversion ratio also known as the gear ratio, is designed to match the high-speed generator with the low-speed turbine blades. For a given rated speed of the generator and turbine, the gearbox ratio can be determined by

$$r_{gb} = \frac{n_m}{n_M} \cdot \frac{(1-S)60fs}{P.n_M}$$

Where n_m and n_w are the generator and turbine rated speeds in rpm, s is the rated slip, f_s is the rated stator frequency in Hz, and P is the number of

pole pairs of the generator. The rated slip is usually less than 1% for large induction generators, and zero for synchronous generators

Generator : The conversion of rotational mechanical energy to electric energy is performed by the generator. Different generator types have been used in wind energy systems over the years. These include the squirrel cage induction generator (SCIG), doubly fed induction generator (DFIG), and synchronous generator (SG) (wound rotor and permanent magnet) with power ratings from a few kilowatts to several megawatts, The SCIG is simple and rugged in construction. It is relatively inexpensive and requires minimum maintenance. Traditional direct grid-connected wind energy systems are still available in today's market.

C. Piezo electric energy:

Piezoelectric materials belong to a broader class called ferroelectrics. One of the defining traits of a ferroelectric material is that the molecular structure is oriented such that the material has local charge separations, known as electric dipoles.

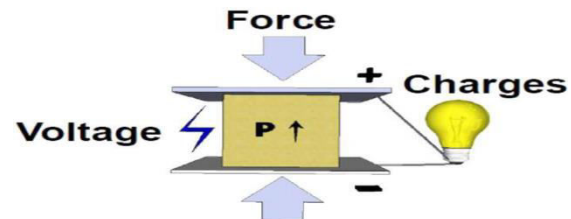

The essence of the piezoelectric effect works as follows: by applying a mechanical stress to a crystal, one can generate a voltage or potential energy difference, and thus a current. Piezoelectric generator principle states that the conversion chain starts from vibration for which a mechanical energy source is required. The vibrations are converted into electricity via piezoelectric element. The electricity produced is then afterward formatted by a static converter before supplying the load (electrical device). Piezoelectric generators work due to the piezoelectric effect. This is the ability of certain materials to create electrical potential when responding to mechanical changes. To make it simpler, we can say that when compressed or expanded or while changing shape a piezoelectric material will give output as some voltage.

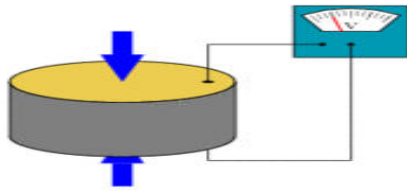

FIG: power generation using Piezo crystal

grid voltage is not fixed for a microgrid. The chosen loads for this project has rated voltage varies in the range from 5 V to 230 V. For ensuring a coherent transition from grid voltage to rated load voltage, an optimum value of grid voltage of 72 V is chosen

Since the majority of the domestic electrical appliances internally needs DC voltage for its operation, which is obtained conventionally by stepping down of rectified AC voltage supply. Renewable energy resources can directly produce this low value of DC voltage. Hence the rectification stage can be avoided if the load is powered with DC. A customary magnitude for DC

3.1 Block Diagram:

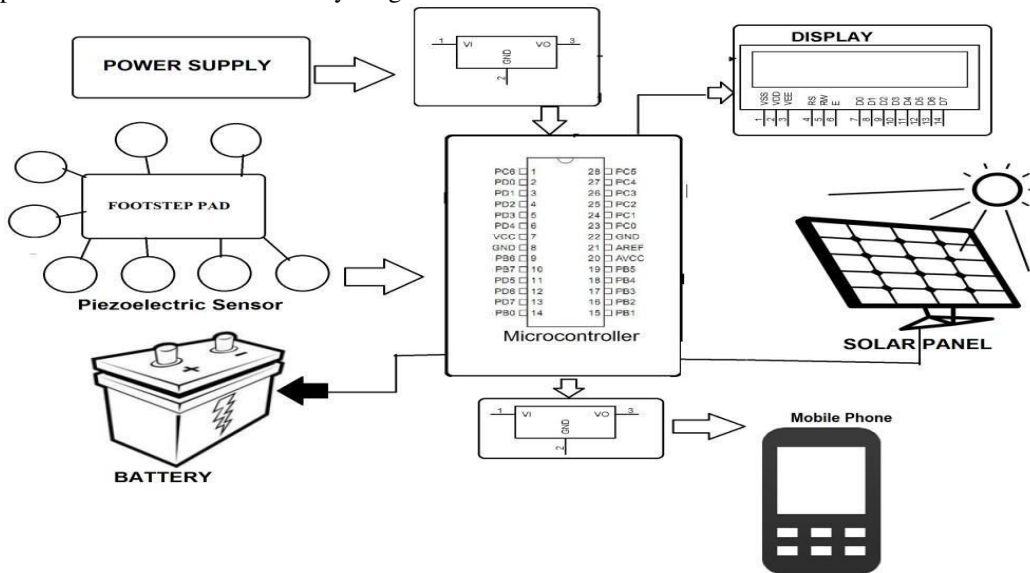
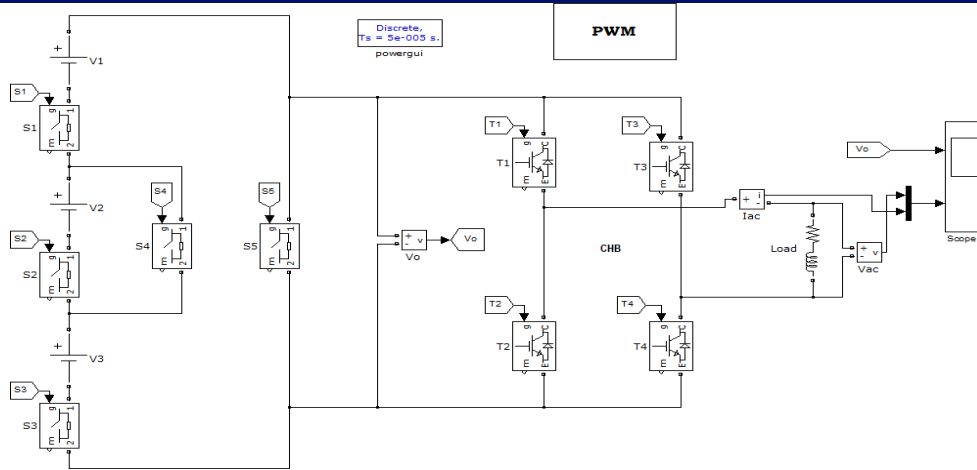
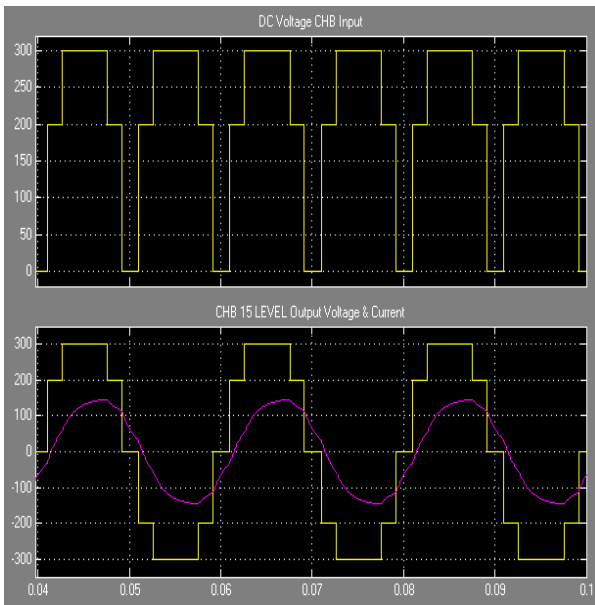

Fig 3.1 Block diagram of the proposed charging system

4.1 SIMULINK MODELING AND DESIGNING



Simulink model of 4.1 outputs :



Proposed basic unit output waveform

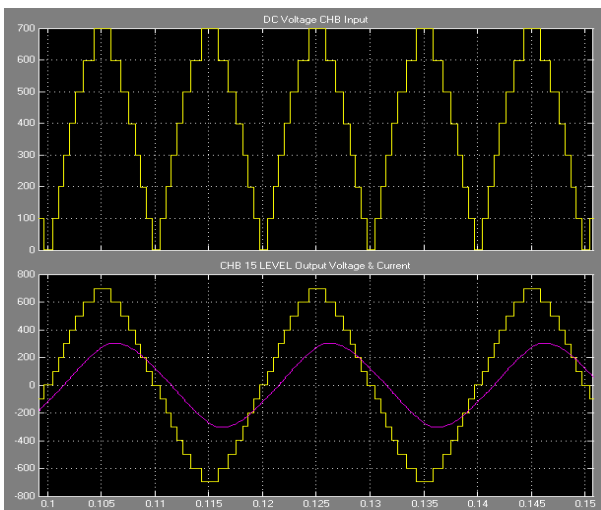

Output voltage waveforms of each unit

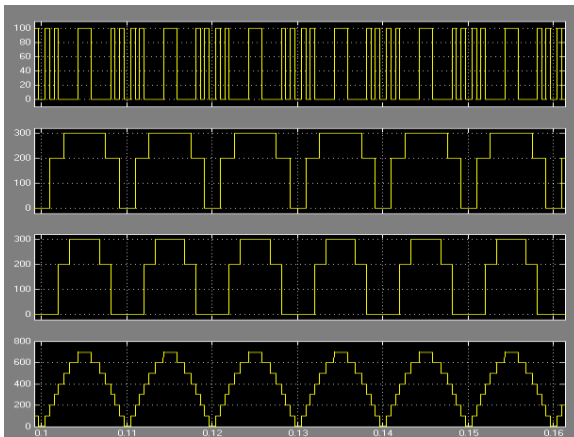

Waveforms of the DC Voltage and load voltage and current

5. CONCLUSION:

This project “DESIGN AND MODELING OF MICROGRID WITH INTEGRATION OF MULTIPLE RENEWABLE ENERGY SOURCES” is successfully tested and implemented which is the best economical affordable energy solution to common people. By using this project we can drive both A.C. as well as D.C loads according to the force we applied on the piezo electric sensor. Our prototype demonstrates that a floor generator can be done.

Proposal for the utilization of waste energy of foot power with human locomotion is very much relevant and important for highly populated countries like India and China. The whole human/bio-energy being wasted if can be made possible for utilization, it will be great invention and crowd energy farms will be very useful energy sources in crowded countries.

The model of wind energy conversion system is simulated for supplying electrical energy to AC and DC loads. The power available from a WECS is very unreliable in nature and hence it cannot ensure uninterrupted power flow to the loads. In order to meet the load requirement at all instants, Suitable storage device is needed. Therefore, hybrid wind battery system is chosen to supply desired power to DC loads. In this project simulation study is done on Wind energy conversion system fed islanded DC load, wind energy conversion system fed stand alone AC load, wind turbine generation fed AC load, Hybrid wind battery system fed AC and DC loads.

REFERENCES:

1. Sieminski, A. Annual Energy Outlook 2015; US Energy Information Administration: Washington, DC, USA, 2015.
2. Loomba, P.; Asgotraa, S.; Podmore, R. DC solar microgrids—A successful technology for rural sustainable development. In Proceedings of the IEEE PES Power Africa, Livingstone, Zambia, 28 June–2 July 2016; pp. 204–208.
3. Jhunjunwala, A.; Aditya, L.; Prabhjot, K. Solar-dc microgrid for Indian homes: A transforming power scenario. *IEEE Electr. Mag.* 2016, 4, 10–19.
4. Chandel, S.S.; Shrivastva, R.; Sharma, V.; Ramasamy, P. Overview of the initiatives in renewable energy sector under the national action plan on climate change in India. *Renew. Sustain. Energy Rev.* 2016, 54, 866–873.
5. Makarabbi, G.; Gavade, V.; Panguloori, R.B.; Mishra, P.R. Compatibility and performance study of home appliances in a DC home distribution system. In Proceedings of the IEEE International Conference on Power Electronics, Drives and Energy Systems (PEDES), Mumbai, India, 16–19 December 2014.
6. R. C. Bansal, —Three-phase self-excited induction generators: An overview, *IEEE Trans. Energy Convers.*, vol. 20, no. 2, pp. 292–299, Jun. 2005.
7. S. C. Tripathy, M. Kalantar, and N. D. Rao, —Wind turbine driven self excited induction generator, *Energy Convers. Manag.*, vol. 34, no. 8, pp. 641–648, 1993.



8. A. Chakraborty, —Advancements in power electronics and drives in interface with growing renewable energy resources,| Renewable Sustainable Energy Rev., vol. 15, no. 4, pp. 1816–1827, May 2011.