



International Journal for Innovative Engineering and Management Research

A Peer Reviewed Open Access International Journal

www.ijiemr.org

COPY RIGHT



ELSEVIER
SSRN

2022IJIEMR. Personal use of this material is permitted. Permission from IJIEMR must be obtained for all other uses, in any current or future media, including reprinting/republishing this material for advertising or promotional purposes, creating new collective works, for resale or redistribution to servers or lists, or reuse of any copyrighted component of this work in other works. No Reprint should be done to this paper, all copy right is authenticated to Paper Authors

IJIEMR Transactions, online available on 28th Sep 2022. Link

[:http://www.ijiemr.org/downloads.php?vol=Volume-11&issue=ISSUE-09](http://www.ijiemr.org/downloads.php?vol=Volume-11&issue=ISSUE-09)

DOI: 10.48047/IJIEMR/V11/ISSUE 09/36

Title **GRID-INTERFACE VARIABLE-SPEED PERMANENT MAGNET WIND TURBINE GENERATORS BASED SOFT SWITCHING TECHNIQUE Z-SOURCE INVERTER**

Volume 11, Issue 09, Pages: 311-317

Paper Authors

Mrs. B. Patrisamma, Mr. Ch S K B Pradeep Kumar, Mrs. Ch. Sabitha, Ms. Ch K T S R Kowstubha, Ms. D Saiprasanthi



USE THIS BARCODE TO ACCESS YOUR ONLINE PAPER

To Secure Your Paper As Per **UGC Guidelines** We Are Providing A Electronic Bar Code

GRID-INTERFACE VARIABLE-SPEED PERMANENT MAGNET WIND TURBINE GENERATORS BASED SOFT SWITCHING TECHNIQUE Z-SOURCE INVERTER

Mrs. B. Patrisamma, Assistant Professor, EEE Department, Ramachandra College of Engineering, Eluru
Mr. Ch S K B Pradeep Kumar, Assistant Professor, EEE Department, Ramachandra College of Engineering, Eluru

Mrs. Ch. Sabitha, Assistant Professor, EEE Department, Ramachandra College of Engineering, Eluru
Ms. Ch K T S R Kowstubha, Assistant Professor, EEE Department, Ramachandra College of Engineering, Eluru
Ms. D Saiprasanthi, Assistant Professor, EEE Department, Ramachandra College of Engineering, Eluru

ABSTRACT- A Z-source inverter based grid-interface for a variable-speed wind turbine related to a permanent magnet synchronous generator is proposed. A manipulate device is designed to reap most wind electricity underneath varied wind situations with using a permanent magnet synchronous generator, a diode-rectifier and a Z-source inverter. Control systems for speed law of the generator and for DC- and AC- aspects of the Z-source inverter are implemented. Simulation effects are used to verify the efficacy of the proposed method.

I INTRODUCTION

RECENT trends in meeting increasing strength demand are shifting closer to generating power with allotted electricity sources, and maximum of them are renewable as they have got extra blessings because of their environmentally pleasant nature and their potential of on-site era. Furthermore, reliability of provider and energy great are more advantageous by using proximity to the consumer. This concept is normally called disbursed technology (DG) and it has gained reputation through the years. The DG enhances centralized technology through having a highly cheaper response to incremental increases in electricity demand, via preventing existing transmission and distribution ability improvements, through locating electricity where it is maximum desired and via having the flexibility to position electricity lower back into the grid at person web sites. Moreover, there are social demands for less expensive, less polluting, more secure and more reliable and sustainable energy for clients, providers, turbines and coverage makers. The DG, inclusive of integration of renewable sources, is a promising method to solve the ones demands.

However, such renewable assets are dispensed and technology and standards essential for their grid interconnection and isolated operation are presently

being evolved. There are severa types of DG energy assets generating electrical electricity at one of a kind voltages and frequencies. Such disparity in output traits may be located even in assets like wind generators, gasoline cells and solar cells, all of them have a excessive capability to be dominant DG resources in future. Hence, it is vital to convert the output voltage and frequency of such sources to conventional values to be compatible with home and business loads.

This can be achieved with a electricity conditioner. Traditionally, there are sorts of inverters used; generally referred to as voltage supply inverter (VSI) and current source inverter (CSI). Both of those inverters have confined working variety despite the fact that each are used in DG applications [1, 2]. To triumph over the confined running variety, both these inverters want to be linked with a separate DC-DC converter stage on the front cease. This enables them to operate in both greenback and raise modes. This topology is usually referred to as a -level inverter. Small scale -degree inverters were developed for home DG programs with gasoline cells [3, 4]. However, two-level inverters aren't price effective and additionally controlling them is understood to be bulky. As a approach to this trouble, Z-source inverter turned into proposed currently [5]. This is a unmarried-degree inverter and it can operate in both greenback and raise modes. The buck-boost feature is done due to the precise impedance network interfacing the inverter with the DC supply. Moreover, it has higher EMI houses because of the absence of the useless-time. Amongst sustainable assets, wind electricity has received speedy development and has made a vast in-avenue into electrical energy systems as a potential source of bulk energy generation. Wind power is derived from small area harnessing schemes as well as huge wind farms that could generate substantial quantity of power to masses [6-8].

Unfortunately, just like different renewable assets which includes solar, wind technology has a tendency to be unsteady because wind velocity is prompted by way of natural and meteorological conditions. Notwithstanding such drawbacks, wind electricity has been located to be a technically and economically possible choice for producing energy. With the advent of high velocity and efficient energy electronic devices and variable-speed direct-pushed mills, a quiet and low-budget wind generation system has turn out to be a reality. Synchronous turbines were used for direct-coupled and occasional-pace wind era applications.

Particularly, permanent magnet (PM) kind synchronous mills had been gaining attractiveness for such applications lately as they're particularly efficient and are of incredibly smaller in diameter. The AC voltage produced by means of PM generators can be rectified to generate a easy DC voltage the use of a simple diode rectifier to lessen the fee. The output of the aggregate of PM generator and diode rectifier is uncontrollable in nature as PM turbines lack excitation control. To interface such widely various DC voltage to the mains grid, a Z-supply inverter based totally single converter degree is proposed on this paper. The proposed topology is competitively priced and much less complicated in comparison to standard -level converter topologies. The control methodologies of the proposed converter topology are supplied along with simulation and experimental effects to expose the efficacy of the proposed approach.

II. SYSTEM CONFIGURATION

The proposed Z-supply inverter based totally PMSG wind turbine device is illustrated in Fig. 1. In the determine, the PMSG converts the wind turbine captured wind electricity to electric shape, which is denoted via P_w . As wind velocity is intermittent in nature, P_w would range with time [8].

The front-cease converter rectifies the generated AC electricity output right into a DC voltage, v_{dc} across the DC-link capacitor, C_1 . The fluctuation in wind power outcomes within the variant of the DC-hyperlink voltage. To convert the variable DC voltage into an AC shape with unique voltage and frequency, the Z-source inverter is proposed as proven in Fig. 1. The Z-source inverter includes Z-source impedance network linked to DC-side of a fashionable PWM voltage source inverter. With a suitably designed controller, the Z-supply inverter can perform beneath varied DC-hyperlink voltage situations while maintaining the value of inverter output voltage, v_o steady.

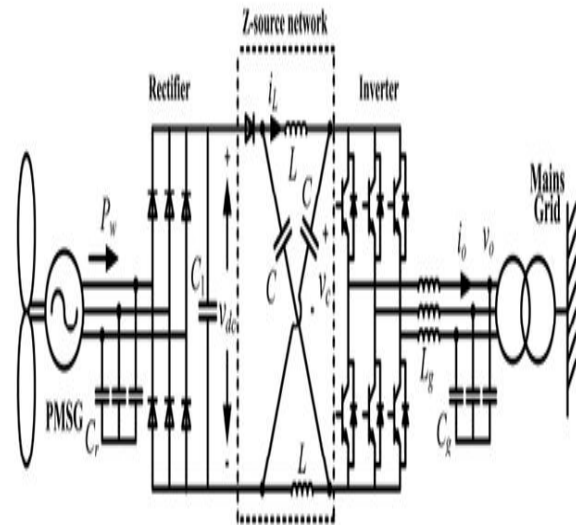

Fig. 1. Wind power generation scheme with Z-source inverter grid interface.

III. CONTROLLER DESIGN

The manipulate machine of the Z-supply inverter based totally wind power machine is proven in Fig. 2.

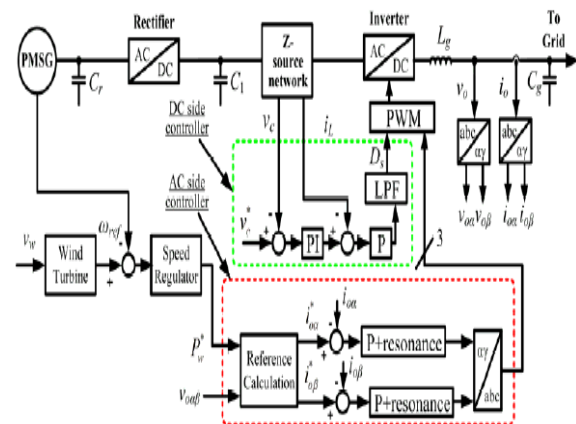

Fig. 2. Control scheme of the Z-source inverter based wind power generation system.

The basic device incorporates of the DC-aspect manage loop and the AC-aspect control loop, as proven in inexperienced- and pink-containers respectively. In the following sub-sections, the details of the two controllers are discussed in element

A. Derivation of reference power component for optimal wind power generation

The mechanical electricity P_w transmitted to the wind turbine shaft is given by means of (1) wherein ρ is density of air, A is place swept by blades, V_w is wind velocity and C_p is turbine electricity coefficient. When the pitch angle of the

blade is consistent, the turbine electricity coefficient C_p is a characteristic simplest of the tip pace ratio λ , which is the ratio of the wind turbine blade tip speed to the wind pace V_w as given in (2). In this equation, R is the radius of the blades and ω is the angular speed of the wind turbine shaft.

The version of the energy coefficient with the end speed ratio for a standard wind turbine is proven in Fig. Three. When λ takes the gold standard price λ_{opt} , the electricity coefficient C_p will become maximum at $C_{p,opt}$. When the top pace ratio λ is maintained at its superior price λ_{opt} regardless of the wind speed, the most mechanical electricity may be derived from wind. The most strength this is derived from the wind turbine $P_{w,opt}$ is given in (3) and $P_{w,opt}$ is proportional to the cubic strength of the turbine shaft velocity. In this best circumstance, the generator Tempo is saved proportional to the wind pace, as proven in (four) in which $K_{\omega} = \lambda_{opt} / R$. Therefore, the preferred generator velocity ω_{ref} is sent to a pace regulator to gain a fee for the reference electricity P_w^* which in turn is used to derive reference present day additives for the grid inverter contemporary manage.

It may be visible that if the speed regulator keeps the generators peed at ω_{ref} , $P_{w,opt}$ is transferred to the grid thru strength flow control of the grid-aspect inverter.

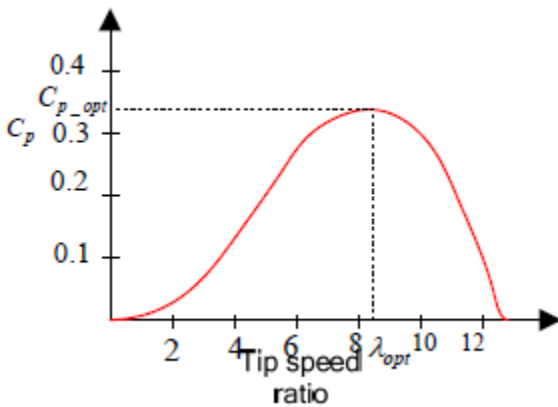

Fig. 3. Variation of power coefficient C_p with tip speed ratio

$$P_w = 0.5\rho AV_w^3 C_p \quad (1)$$

$$\lambda = \frac{RW_w}{V_w} \quad (2)$$

$$P_{w,opt} = \frac{0.5\rho AW_w^3 R^3 C_{p,opt}}{\lambda_{opt}^3} \quad (3)$$

$$\omega_{ref} = K_w V_w \quad (4)$$

B. DC-side controller design

Similar to the controller design proposed in [9], the Z supply inverter inside the proposed scheme is modeled as cascaded sub systems with time scale

decoupling among them. The controllers are designed independently. The AC facet voltage disturbances would have minimal effect at the DC-facet. However, the changes in grid cutting-edge could alter the inductor contemporary of the Z-source impedance network. Grid cutting-edge versions may be taken into consideration as a disturbance inside the AC-side and can be compensated for. However, to prevent the clashes among the dynamics of AC- and DC-sides, the DC aspect dynamics should be made considerably slower. This can be supported by having a higher bandwidth within the AC facet voltage and modern loops. Small sign evaluation is carried out to acquire a linear version of the Z-source impedance network. Its block diagram representation is shown in Fig. Four, which shows the relationship between kingdom variables and shoot-thru responsibility ratio, in which $V_{11}=2V_c-V_{dc}-RIDC$ and $I_{11}=2I_L-IDC$, $DS =$ shoot-thru kingdom obligation-ratio, $DA=$ non shoot-via state obligation-ratio [9]. In contrast to the controller design proposed in [9], controllers here are designed to control the voltage throughout the Z-supply capacitor, because of two reasons. First, the output voltage of Z-source impedance network is pulsating and secondly, this would allow the switches to have minimal voltage stress underneath various conditions and the boosted voltage might be effectively utilized.

From Fig. 4, the transfer function of $(\tilde{V}_c / \tilde{D}_c)$ is derived as proven in (5), but, it has a RHP zero. This is a clean indication of the presence of non-minimum phase. Hence, the layout of closed-loop controllers should be performed cautiously.

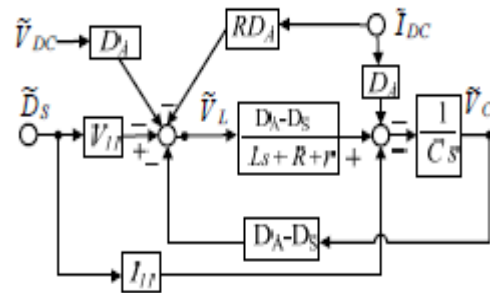

Fig. 4. Block diagram representation of Z-source impedance network.

$$\frac{\tilde{V}_c}{\tilde{D}_s} = \frac{2V_c - V_{dc} - RI_{dc} - (2I_L - I_{dc})(R+r) - L(2I_L - I_{dc})s}{LC_s^2 + (R+r)Cs + (D_A - D_S)^2} \quad (5)$$

$$\frac{\tilde{I}_L}{\tilde{D}_s} = \frac{(2V_c - V_{dc} - RI_{dc})Cs}{(LC_s^2 + (R+r)Cs + (D_A - D_S)^2)} \quad (6)$$

$$\frac{\bar{V}_c}{\bar{I}_L^*} = \frac{K_{LP}((2V_c - V_{dc} - RI_{dc})(D_A - D_S) - (2I_L - I_{dc})(R + r) - L(2I_L - I_{dc})s)}{LC_s^2 + (R + r + 2K_{LP}(V_c - V_{dc} - RI_{dc})(D_A - D_S))Cs + (D_A - D_S)^2} \quad (7)$$

The non-minimum phase hassle is handled with having loops, i.e. Inner contemporary and outer voltage loops, and the technique is generally called indirect controller. A comparable technique is proposed here to gain a solid feedback controller. From Fig. 4, the open-loop switch function of the internal modern loop may be derived and is given in (6).

It has no RHP 0 making inner loop layout less tedious and consequently a proportional controller is employed as proven in Fig. 5. Subsequently, the open loop transfer feature for the outer capacitor voltage loop is derived as in (7) and then to attain the required bandwidth and to maintain balance, a PI controller is cascaded. Selected parameters prevent clashes between the dynamics of AC- and DC-sides, because the crossover frequency of the DC-aspect outer-loop is made very much smaller than that of the outer voltage loop inside the AC-facet.

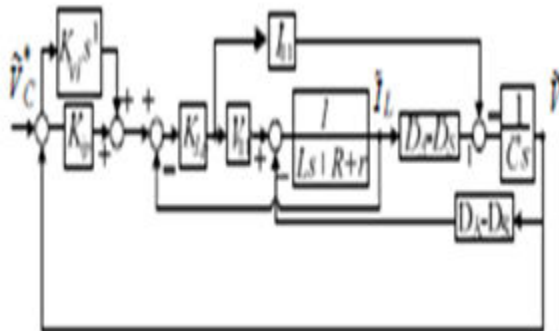

Fig. 5. Block diagram representation of Z-source impedance network with closed current and voltage loops.

C. AC-side controller design

Consider the AC-aspect of Fig. 1 and through making use of KCL and KVL, the mathematical model of the AC-aspect may be derived. The block diagram illustration of the AC-facet is given in Fig. 6. The AC-side output modern is controlled by way of changing the modulation index. The output inverter inductor modern-day size is used because the feed-lower back sign. From Mason's benefit rule, it's far possible to achieve the open-loop switch capabilities for $\alpha\beta$ axes and controllers are designed the usage of the obtained transfer functions.

Recently proposed P+resonance controller is hired to music the contemporary reference [10]. This controller plays like a PI controller designed in

rotating reference frame however with out the computational burden of transformation into the rotating reference frame. In this paper, the aim of the controller design is to supply electricity generated by using the PMSG.

This is carried out by way of injecting the required current into the grid. However, with the modifications in grid voltage and in wind speed, the modern-day reference needs to be changed continuously. The reference currents are generated the use of instantaneous energy theory [11] and are given in (8) and (nine) within the $\alpha\beta$ reference body. * w P is the energy reference from the PMSG regulator and vo α and vo β are the measured grid voltage components inside the stationary reference frame.

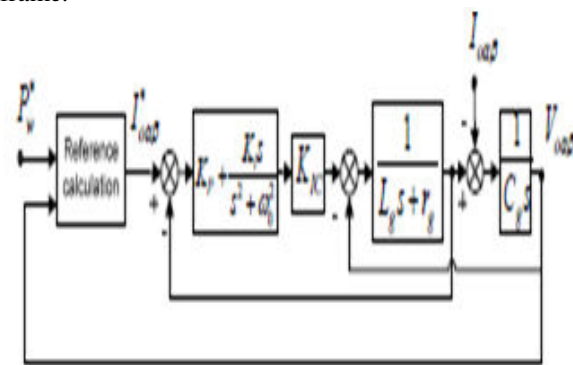

Fig. 6. Block diagram of the AC side closed loop controller

$$I_{O\alpha}^* = \frac{V_{O\alpha}}{V_{O\alpha}^2 + V_{O\beta}^2} P_w^* \quad (8)$$

$$I_{O\beta}^* = \frac{V_{O\beta}}{V_{O\alpha}^2 + V_{O\beta}^2} P_w^* \quad (9)$$

IV SOFT SWITCHING TECHNIQUE

Today tender-switching approach may be very essential in modern era. In this technique 0 voltage and zero modern switching had been used which progressed the performance as compared to difficult-switched PWM Inverter. Soft switching approach advanced from load resonant to quasi resonant mentioned in. In quasi-resonant method resonant network is activated at some point of resonant interval to allow soft-switching. Z source inverter DC link for voltage supply inverter had been mentioned in.

A two transfer resonant hyperlink inverter is reported for operates with team spirit strength thing load. A switch quasi-resonant topology having displacement factor identical to zero.88 legging can be handle passive load. A resonant snubber primarily based topology in is proposed for lively and passive load. The adjust topology of quasi-resonant technique

this adjust topology has a limitation which restrict high strength aspect load operation. A current managed tender-switching inverter which gives accurate sinusoidal waveform of current for induction device in.

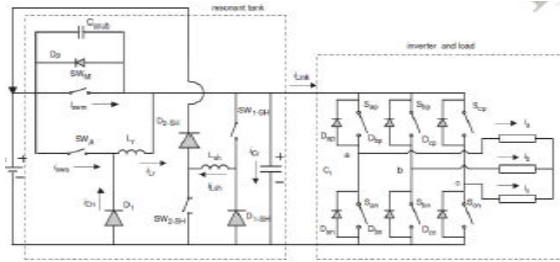

Figure 7 Proposed Quasi-Resonant soft switched three phase inverter

V.SIMULATION VERIFICATIONS

To confirm the effectiveness of the proposed manipulate schemes, the Z-supply inverter based totally wind integration system is constructed inside the MATLAB. The advanced prototype is a scaled down model of the real system and is shown in Fig. 1 with the exception that a DC gadget is used to emulate the wind turbine because the prime mover of PMSG. A 3 phase AC power deliver related to a resistive load financial institution is used to emulate the grid. The simulation system parameters are given in Table I. Figs. 8 and 9 display the simulation consequences received from the matlab.

Table I: Parameters for the simulation

Parameter	Value
L	5 mH
C	2200 μ F
C ₁	6800 μ F
L _z	5 mH
C _z	25 μ F
R _{load}	25 Ω
M-max	0.9
D _r -max	0.35
DC machine, P _{rated}	1.2 kW
DC machine, ω_{rated}	1400 rpm
DC machine stator, V _{rated}	220 V
DC machine stator, I _{rated}	6.0 A
DC machine exciter, V _{rated}	220 V
DC machine exciter, I _{rated}	0.55 A
PMSG, P _{rated}	1.5 kW
PMSG, V _{rated}	400 V
PMSG, Poles	4
PMSG, ω_{rated}	1500 rpm (@ 50 Hz)

The simulation verifications of the AC- and DC-side controllers of the Z-source inverter have been done and the results are given in Figs. 8 and 9 respectively.

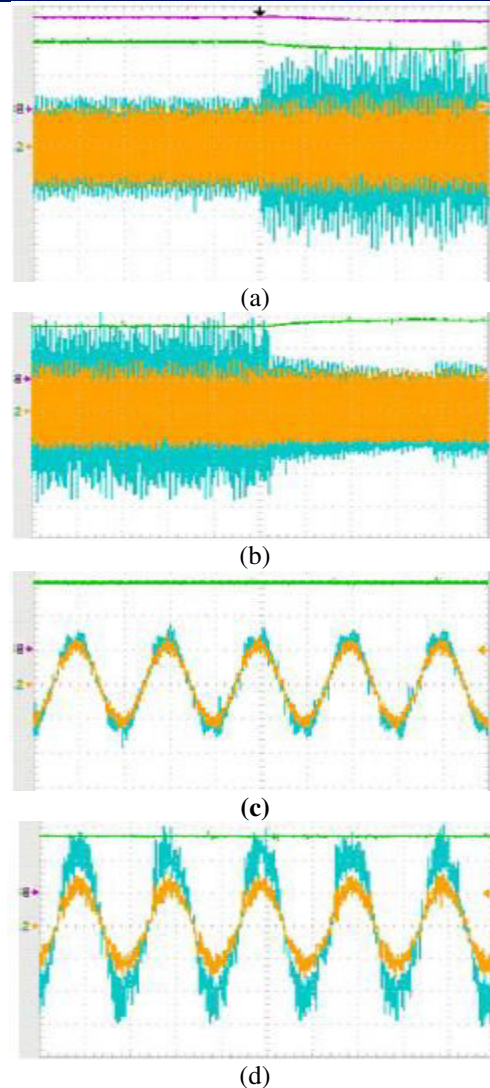
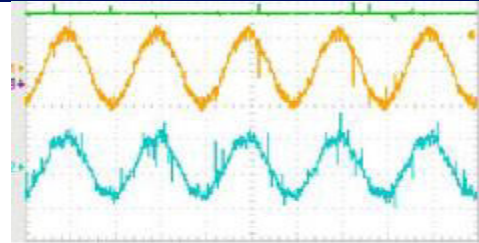
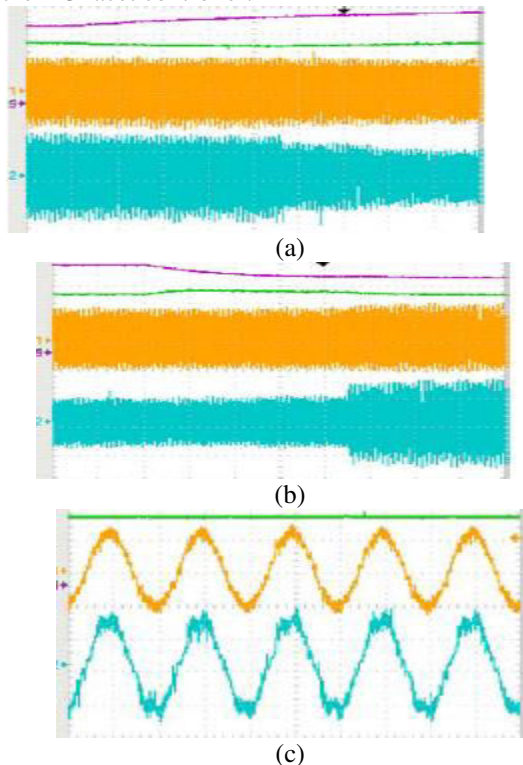

Fig. 8. Simulation results, (a) for a reduction in reference speed, waveforms of the Z-source impedance network capacitor voltage 50 V/div, input DC voltage 50 V/div, output voltage 10 V/div and output current 1 A/div (from top to bottom), (b) for an increase in reference speed, waveforms of the Z-source impedance network capacitor voltage 50 V/div, input DC voltage 50 V/div, output voltage 10 V/div and output current 1 A/div (from top to bottom), (c) AC output voltage 10 V/div (orange) and current 1 A/div (blue) waveforms at the speed of 53 rad/s, and (d) AC output voltage 10 V/div (orange) and current 1 A/div (blue) waveforms at the speed of 50 rad/s.

In the simulation, the Z-supply impedance community capacitor reference voltage is stored consistent and step adjustments within the PMSG reference speed are done. The waveforms of the Z-source impedance network capacitor voltage, input DC voltage, output voltage and output contemporary

at some point of the velocity step-down and step-up transitions are shown in Figs. 8(a) and (b) respectively. From Fig. 8(a), you can still locate that, with the speed reference is decreased from fifty three rad/s to 50 rad/s, the output energy from the DC device is extended as top mover methods its maximum energy with the lower of the speed and therefore, the AC-aspect output cutting-edge is stepped-up.

Though the input DC voltage decreases due to the PMSG velocity is reduced, the Z-source impedance community capacitor voltage is nicely controlled and saved at its unique cost over this transition c programming language. The waveforms reveal that, with the reference pace changes returned from 50 rad/s to 53 rad/s, the AC-side output modern-day is correspondingly restored to its authentic fee. The capacitor voltage is once more well controlled while the input DC voltage is decreased with the discount of the PMSG velocity. The AC output voltage- and present day-waveforms inside the excessive pace (53 rad/s) and low pace (50 rad/s) conditions are highlighted in Figs. 8(c) and (d) respectively. The 2d simulation is achieved to verify the effectiveness of the DC facet controller.



(d)

Fig. 9. Simulation results, (a) for a Z-source capacitor voltage reference increase, waveforms of the Z-source impedance network capacitor voltage 50 V/div, input DC voltage 50 V/div, output voltage 10 V/div, and output current 1 A/div (from top to bottom), (b) for a Zsource capacitor voltage reference decrease, waveforms of the Z-source impedance network capacitor voltage 50 V/div, input DC voltage 50 V/div, output voltage 10 V/div, and output current 1 A/div (from top to bottom), (c) AC output voltage 10 V/div (orange) and current 1 A/div (blue) waveforms at a capacitor voltage of 140 V, and (d) AC output voltage 10 V/div (orange) and current 1 A/div (blue) waveforms at a capacitor voltage of 170 V.

In this simulation, the PMSG reference pace is kept unchanged at fifty three rad/s, even as the Z-source impedance community capacitor voltage reference is changed from one hundred forty V to one hundred seventy V and returned to 140 V. The waveforms of the Z-source impedance community capacitor voltage input DC voltage, output voltage and output modern-day in the course of the step transitions are proven in Figs. 9(a) and (b). At the authentic condition, the input DC voltage is enough to provide the preferred Z-source impedance network capacitor voltage without shoot-through. With the capacitor voltage reference is extended to one hundred seventy V, shoot-thru periods need to be inserted to reinforce up the Z-supply impedance community capacitor voltage at the same time as the DC input voltage is maintained constant with the PMSG velocity is managed unchanged. In this example Dsh for the Z-source is observed to be zero.2 with modulation index = 0.3. In the original situation, modulation index = zero.6 with Dsh = 0. When the capacitor voltage reference is decreased to 140 V, the capacitor voltage decreases as shown in Fig. Nine(b). The DC input voltage stays unchanged, revealing the truth that the PMSG pace is well managed. The waveforms of the AC-side voltage and contemporary for capacitor voltage reference settings of one hundred forty V and one hundred seventy V are given in Figs. 8(c) and (d) respectively.

VI. CONCLUSIONS

A wind power integration topology based on Z-source inverter system is proposed in this paper. With the employment of the proposed Z-source inverter, the AC-aspect voltage is maintained consistent even though the DC-link voltage of the front give up rectifier has a tendency to differ due to the stochastic nature of the wind. The DC- and AC-aspect controllers for the Z-source inverter are designed. The DC-aspect controller includes cascaded sub-systems which can be designed with the usage of time scale decoupling between them. With the usage of certainly selected PI constants, the DC-aspect voltage disturbances might have minimal impact at the AC-aspect. The these days proposed P+resonance controller is carried out to the AC manage device. The output current is managed to track the fluctuating wind electricity generated from the PMSG. The effectiveness of the proposed controllers has been proven by way of Simulation outcomes.

VII. REFERENCES

- [1] E. Twining and D. G. Holmes, "Grid current regulation of a three-phase voltage source inverter with an LCL input filter," *IEEE Transactions on Power Electronics*, vol. 18, no. 3, pp. 888-895, 2003
- [2] Y. Li, D. M. Vilathgamuwa, and P. C. Loh, "Design, analysis, and realtime testing of a controller for multibus microgrid system," *IEEE Transactions on Power Electronics*, vol. 19, no. 5, pp. 1195-1204, 2004.
- [3] A. M. Tuckey and J. N. Krase, "A low-cost inverter for domestic fuel cell applications," in *Proceedings of Power Electronics Specialists Conference*, vol. 1, pp. 339-346 vol.1, 2002.
- [4] J. Wang, et al., "Low cost fuel cell converter system for residential power generation," *IEEE Transactions on Power Electronics*, vol. 19, no. 5, pp. 1315-1322, 2004.
- [5] F. Z. Peng, "Z-source inverter," *IEEE Transactions on Industry Applications*, vol. 39, no. 2, pp. 504-510, 2003.
- [6] F. Blaabjerg and Z. Chen, *Power electronics for modern wind turbines*. San Rafael, Calif.: Morgan & Claypool Publishers, 2006.
- [7] Z. Chen and E. Spooner, "Grid interface options for variable-speed, permanent-magnet generators," *IEE Proceedings: Electric Power Applications*, vol. 145, no. 4, pp. 273-283, 1998.
- [8] S. Heier, *Grid integration of wind energy conversion systems*, 2nd ed., Chichester, England; Hoboken, NJ: Wiley, 2006.
- [9] C. J. Gajanayake, D. M. Vilathgamuwa, and L. Poh Chiang, "Development of a Comprehensive Model and a Multiloop Controller for Z-Source Inverter DG Systems," *IEEE Transactions on Industrial Electronics*, vol. 54, no. 4, pp. 2352-2359, 2007.
- [10] D. N. Zmood and D. G. Holmes, "Stationary frame current regulation of PWM inverters with zero steady-state error," *IEEE Transactions on Power Electronics*, vol. 18, no. 3, pp. 814-822, 2003.
- [11] H. Akagi, S. Ogasawara, and K. Hyosung, "The theory of instantaneous power in three-phase four-wire systems: a comprehensive approach," in *Proceedings of IEEE Industry Applications Society Annual Conference 1999*, vol. 1, pp. 431-439 vol.1, 1999.