



International Journal for Innovative Engineering and Management Research

A Peer Reviewed Open Access International Journal

www.ijiemr.org

COPY RIGHT



ELSEVIER
SSRN

2023 IJIEMR. Personal use of this material is permitted. Permission from IJIEMR must be obtained for all other uses, in any current or future media, including reprinting/republishing this material for advertising or promotional purposes, creating new collective works, for resale or redistribution to servers or lists, or reuse of any copyrighted component of this work in other works. No Reprint should be done to this paper, all copy right is authenticated to Paper Authors

IJIEMR Transactions, online available on 18th Feb 2022. Link

[:http://www.ijiemr.org/downloads.php?vol=Volume-12&issue=Issue 02](http://www.ijiemr.org/downloads.php?vol=Volume-12&issue=Issue 02)

DOI: 10.48047/IJIEMR/V12/ISSUE 02/69

Title Ambulance Clearance Smart IoT System

Volume 12, ISSUE 02, Pages: 434-438

Paper Authors

D. Srinivasa Reddy, J.P. Kanti, G.Jyothsna, MD. Imdaad



USE THIS BARCODE TO ACCESS YOUR ONLINE PAPER

To Secure Your Paper As Per **UGC Guidelines** We Are Providing A Electronic Bar Code

Ambulance Clearance Smart IoT System

D. Srinivasa Reddy¹, J.P. Kanti², G.Jyothsna³, MD. Imdaad⁴

Asst. Professor, Dept. of Electronics, P.B. Siddhartha College of Arts & Science, Vijayawada¹

H.O.D, Dept. of Electronics, Sri Durga Malleswara Siddhartha Mahila Kalasala, Vijayawada²

Lecturer, Dept. of Electronics, Sri Durga Malleswara Siddhartha Mahila Kalasala,
Vijayawada³

U.G, Student, Dept. of Electronics, P.B. Siddhartha College of Arts & Science, Vijayawada⁴

Email: dsrinivasareddy@pbsiddhartha.ac.in

Abstract

The obtainable time based traffic management system is not suitable and friendly for the present day traffic. Due to this many emergency service vehicles like fire service; ambulance was prevented from doing their services on time. The increase in Vehicle population demands a major change in the current Traffic management systems. There are some systems which uses image processing technology for efficient traffic management in urban areas. But these technologies are usable only in developing countries as they are more complex and expensive. This project addresses the given problem statement by automating the traffic signal control from the ambulance's driver end. The ambulance driver will have a mobile app installed in his mobile which will have the emergency mode toggle. When the emergency mode is on, the device will find the nearest traffic signal using GPS and it will send request to the control room for getting the current signal status. If the signal is already green, it will get the remaining time and based on the remaining time, the app will automatically control the signal and freezing the signal till the ambulance crosses with the help of Blynk. And if the signal is red, again based on the time left, the system will calculate the distance of ambulance from the signal and then it will send the data to Blynk for opening that particular route where the ambulance is running. This will help the ambulance drivers to run freely without getting locked in the traffic. Due to Lack of traffic control leads to loss of lives due to ambulances getting stuck in traffic jams. To overcome this situation, we propose Global Position based Automatic Lane Clearance System. The function of this is to reduce the delay in arrival of the ambulance to the hospital by automatically clearing the lane in which ambulance is travelling, before it reaches the traffic signals. This can be possible by turning the traffic signal, in the path of the ambulance, to green when the ambulance is at a certain distance from the traffic junction. The communication gap among the traffic signal and the ambulance is done through transceivers and GPS. The system is fully automated and not requires any human intervention at the traffic junctions.

Keywords: Internet of Things (IoT); ESP32; NodeMCU; Traffic Lights; Global Positioning System;

Introduction

All countries are very strict in traffic rules, but we all know that ambulances need not to follow the traffic rules during emergency situation as they are a lifesaver. But the problem is, if an ambulance is in a traffic signal and 100 vehicles are in front of ambulance, it is not possible for every vehicle to give way

to the ambulance. If signal waiting time is 3 minutes, the ambulance at least has to wait for 3 minutes to cross the signal. In an emergency situation, even these 3 minutes play a vital role in saving a life. Hence, we come up with an idea to control the traffic signal with the help of ambulance driver's Smartphone itself. This will considerably reduce the waiting

time of the ambulance in signals and therefore we can save lot of lives.

Ambulance Clearance Using IOT System uses this technology in day-to-day life by the hospital authorities. Normal people, cab operators, and other owned vehicle are also use IoT technology. Now-a-days GPS is used in utmost vehicles which we seen around us especially in ambulances, police jeeps, and rental cars. In India, most of the government vehicles such as local buses, bank vans, and petroleum carrying vehicle are using GPS technology that provides the tracking information of vehicle like status and exact location.

In general, GPS tracking technology found in vehicles to ensures the safety of the passengers, prevent theft and to rescue devices. Our intention to the society is to provide faster access to reach the spot of accident and to reach the hospital by clearing the traffic signals as long as ambulance reaches the signal of traffic which is easily pass through. Time is very valuable in medical emergencies this technology will save many human lives.

Related Work

India is most populous country in the World and also a fast growing economy. It seems dreadful road blocking problems in the cities. Growth of Infrastructure is slow when compared with growth in number of vehicles, due to cost and space constraints also Indian traffic is non lane based and messy. It needs a solution to control traffic, which should be unique from the developed Countries. Intelligent traffic management flows can reduce the pessimistic impact of blockage. In recent times, wireless connections are commonly used in the road transport as they provide more gainful option. GPS based traffic control can provide cost valuable solution. GPS modules have very small processors and minimal antennas that directly receive data sent by satellites from keen RF frequencies. It will receive timestamp from each nearby satellite, along with other useful data.

Proposed System

The main components of this diagram are ESP-32, Node MCU, Traffic Module, GPS Module, LCD Display with I2C

Fig 1. Receiving Section

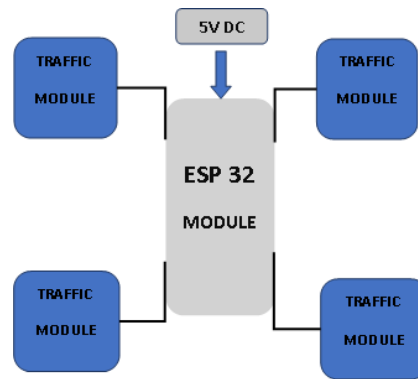

Fig1. The above diagram shows Receiving part of Ambulance Clearance Using IOT System. The main components are:

ESP-32, Traffic Modules (4). The four traffic modules are connected to ESP-32 Controller.

Circuit Diagram For Receiving Part

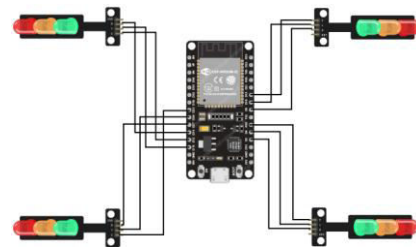

Fig 2. Transmitting Section

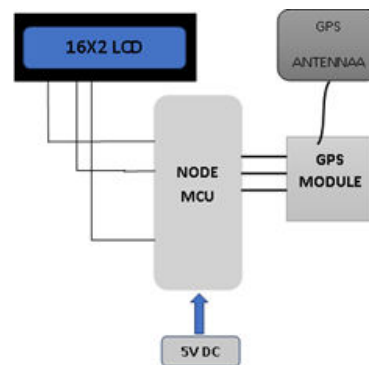
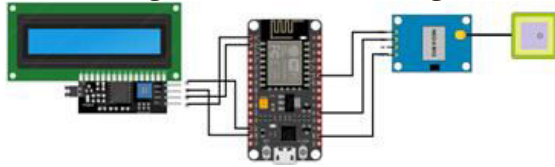

Fig2. The above diagram shows Transmitting part of Ambulance Clearance Using IOT System. The main components are:

NODE MCU (ESP 8266), GPS Module, LCD Display with I2C

Circuit Diagram For Transmitting Part



Devices in the system

Sensor is a device, is to detect actions or changes in the surroundings and send the information to other electronics, commonly a computer processor. In other way the sensors are the device which converts the physical parameter into the electric signal.

1. ESP-32



The heart of the system is CPU is a 32-bit LX6 microprocessor, operates at 160 or 240 MHz and performs up to 600DMIPS. Ultra-low power (ULP) co-processor, with Memory (320 KiB RAM, 448 KiB ROM), also with Wireless connectivity features like Wi-Fi: (802.11 b/g/n) and Bluetooth: v4.2 BR/EDR and BL (shares the radio with WiFi), and with Security features like IEEE 802.11 standard security features all supported, including WPA, WPA2, WPA3 (depending on version) and WLAN Authentication and Privacy Infrastructure (WAPI), Secure boot, Flash encryption and Power management features like Internal low-dropout regulator, Individual power domain for RTC, 5 μ A deep sleep current.

2. NODEMCU



It consists of Microcontroller with Tensilica 32-bit RISC CPU, Operates a voltage of 3.3V and extended with input voltage is 5-12V, it contains 16 DIO pins and one ADC pin, 1-UART, 1-SPI, 1-I2C having flash memory of 4 MB, and 64KB SRAM, 80Mhz-Clock Speed and Wi-Fi-IEEE 802.11 b/g/n

3. GPS Module



The Neo-6M GPS unit is compact and lightweight, offering a range of features at a low price. Its position update rate is five times per second, making it ideal for battery-powered devices with limited resources, Its hot start time 1s and Cold start time is 38s and the default baud rate is 9600.

4. LCD Display with I2C



The LCD has two rows of 16 characters each, and the operating voltage of this LCD is 4.7V-5.3V, The current utilization is 1mA with no backlight. Every character is built with 5 x 8-pixel boxes. There are two modes of like 4 bit & 8 bit, these are obtainable in Blue and Green backlight, it displays few custom generated characters.

5. Traffic Module



The Traffic Module consists of large 8mm Red, Yellow, and Green LEDs that are

active HIGH with built-in current limiting resistors.

IOT Platform - BLYNK

The Blynk app is designed for the Internet of Things and can display sensor data, store data, visualize it, and do many other cool things: This platform consists of three major components.

1. Blynk-App. **2.** Blynk-Server and **3.** Blynk-Libraries

Writing an Node MCU Program:

The Node MCU programming can be done in Arduino IDE software which is free ware firm. When it comes to an Arduino program, there are three sections that make up the program. The first section is at the beginning, and is where you will declare all of your variables. These variables can be values that will be used later on, the number for the ports that will be used, or any other values you will need to have stored for later use. These variables can be of many different types, some of which are: int, float, double, string, Boolean, etc. These data types are the same as those used in other programming languages, and operate the same way. As you can see, variables can be used to describe the numbers that will be used for sensors. This is a more efficient method because if at any point, a pin needs to be changed, one must only change this value at the beginning to change all the values. There are also variables for voltages, which are values that will be used later on for the incoming and outgoing data, and are a good way to keep track of which sensor is giving you what data.

Working Principle

There are mainly two parts in this project

- Transmitter part
- Receiver part

The transmitter part is placed in the Ambulance and it contains GPS module, 16x2 lcd display with I2C both of these are connected to a NODEMCU/ESP8266 & The Receiver part is placed near the traffic signal as shown in the block diagram.

Module 1: Analysis of traffic signal

Firstly, give a 5v DC supply to the NODEMCU and connect it with Wi-Fi Hotspot which is assigned in the sketch at

the same time also give input 5v DC supply to ESP-32 which is in the Receiver part. The longitude and latitude values are shown in the LCD display with the help of GPS module.

The Receiver part is placed near traffic lights, Whenever the ambulance is near a signal i.e., 500 meters behind a signal, an automatic request will be triggered from the app to the control room server for checking the current status of the signal and the waiting time for a change in signal. This module is a recurring one, and it will always alert whenever the ambulance finds a signal.

Module 2: Decision making to switch signal

There are multiple scenarios are possible in this current module. If the signal is already green, and the waiting time is more than 5 seconds then there will be no more requests have been processed from the app. Else if the signal is green and waiting time is less than 5 seconds, then a request will be sent automatically to the server for freezing the signal in green itself till the ambulance crosses the signal. Else if the signal is red then again, a request will be sent to the server to change the signal to green and to freeze it on green, till ambulance crosses.

Module 3: Turning back to normal flow

Once the ambulance crosses the signal, it will be detected using GPS and again a request will be triggered automatically to set back the signal to the normal mode.

Hardware Part & Result

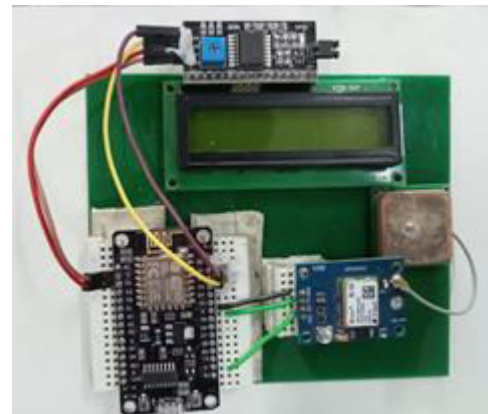

Transmitter Part

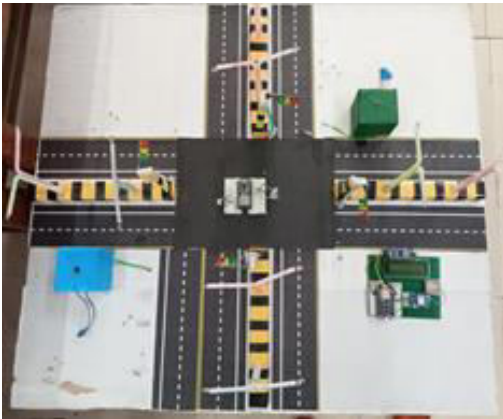

Receiver Part

stationary environments based on multi agent Q-learning,” in Proc.14th Int. IEEE Conf. Intell. Transp. Syst., Oct. 2011, pp. 580 –1585

[4]. V. Srinivasan, Y. Priyadharshini Rajesh, S. Yuvaraj, and M. Manigandan, “Smart traffic control with ambulance detection,” IOP Conf. Ser. Mater. Sci. Eng., vol. 402, no. 1, 2018

[5]. Mohammad Moazum Wani, Samiya Khan, Mansaf Alam, “IoT - Based Traffic Management System for Ambulances”, in research gate

Conclusion

Using this system, traffic police can give the ambulance the right of way when there is heavy traffic. In this technique, the design and operation are openly aimed at traffic management, so emergency vehicles on the road can get to their destinations in less time and without human interference. It is very smart to locate the emergency vehicle and get a clear path to pass. The traffic signal control system for ambulance is proposed successfully and can able to assure millions of lives by saving time in traffic signal. An idea is proposed in this paper for saving patient's life in a fastest manner. So, whenever the ambulance is 500 meters before the signal, the mobile app sends request to the server. Depending on the direction of ambulance, the server changes that specific signal to green. The system has been improved to reduce the death rate in emergencies by taking into consideration the real-time situation.

References

- [1]. D. Ahir, S. Bharade, P. Botre, S. Nagane, and M. Shah, “Intelligent Traffic Control System for Smart Ambulance,” Int. Res. J. Eng. Technol., vol. 5, no. 6, p. 5, 2018
- [2]. K.Manikandan, J. Rizwana,G. Swathi, S. Suhana Safreen, “IOT based Stolen Vehicle Detection and Ambulance Clearance System” in Special Issue – 2017, International Journal of Engineering Research & Technology (IJERT), ISSN: 2278-0181, Volume 5, Issue 13,
- [3]. M. Abdoos, N. Mozayani, and A. L. C. Bazzan, “Traffic light control in non-