



International Journal for Innovative Engineering and Management Research

A Peer Reviewed Open Access International Journal

www.ijiemr.org

COPY RIGHT



ELSEVIER
SSRN

2021 IJIEMR. Personal use of this material is permitted. Permission from IJIEMR must be obtained for all other uses, in any current or future media, including reprinting/republishing this material for advertising or promotional purposes, creating new collective works, for resale or redistribution to servers or lists, or reuse of any copyrighted component of this work in other works. No Reprint should be done to this paper, all copy right is authenticated to Paper Authors

IJIEMR Transactions, online available on 28th March 2021. Link

<https://ijiemr.org/downloads/Volume-10/ISSUE-3>

DOI: 10.48047/IJIEMR/V10/I03/117

Title: **DESCRIPTION OF TEST BENCH AND METHOD FOR MEASURING THE RIGIDITY AND STABILITY OF THIN LAMELLAR KNIVES.**

Volume 10, Issue 03, Pages: 543-546.

Paper Authors:

Barakaev Nusratilla Rajabovich¹, Urinov Nasillo Fayzilloevich², Sohibov Ibodullo Adizmurodovich³, Salliev Ismat Ismatovich⁴



USE THIS BARCODE TO ACCESS YOUR ONLINE PAPER

To Secure Your Paper As Per **UGC Guidelines** We Are Providing A Electronic Bar Code

DESCRIPTION OF TEST BENCH AND METHOD FOR MEASURING THE RIGIDITY AND STABILITY OF THIN LAMELLAR KNIVES.

Barakaev Nusratilla Rajabovich¹, Urinov Nasillo Fayzilloevich², Sohibov Ibodullo Adizmurodovich³, Sailiev Ismat Ismatovich⁴

Doctor of technical sciences, professor. Rector of Bukhara Engineering-Technological Institute¹.
Candidate of technical sciences, associate professor, head of Department of Mechanical Engineering, Bukhara Engineering-Technological Institute².

Doctoral student of Department of Mechanical Engineering, Bukhara Engineering-Technological Institute³.

Lecturer-probationer of Department of Mechanical Engineering, Bukhara Engineering-Technological Institute⁴.

E-mail: urinov1960@mail.ru

Abstract: The article covers the technological reliability of thin lamellar knives in terms of dimensional accuracy and shape of the cut blanks, the main reasons causing the deviation of the cutting edge from the cutting plane have been identified, structural diagram of the lateral deviation of the lamellar knife and experimental setup have been developed.

Keywords: static stability, diagram of technological forces, thin lamellar knife, cutting edge, inertial forces, knife tension, strain modifier, knife stability.

Introduction

Cutting is determined as technological process of material treatment by dividing it into parts under the pressure of a cutting tool [1, 2]. Cutting semi-finished food products in general is a variety of destruction of materials, and is distinguished by the features of technological process, which consists in dividing the product with a cutting tool into parts with certain predetermined dimensions and quality of the cut surface.

The accuracy of the dimensions obtained when cutting blanks is determined by the ability of the cutting body to resist the loads acting on it during operation, which is assessed by its rigidity and stability. Rigidity is characterized by the deflection of the knife under the action of lateral force, and stability is characterized by the ability of the knife to maintain the flat shape of the blade curvature under the action of cutting and feed forces.

Static and dynamic stability should be distinguished when studying the operation of cutting bodies. Static stability is estimated by the value of the critical force at which the blade loses its flat shape and bulges to the side.

Dynamic stability is determined by the conditions of occurrence of resonant parametric oscillations of lamellar knife under the action of variable loads during cutting, in which it loses the ability to resist cutting and feed forces, therefore maintaining the straightness of the cut becomes impossible.

Main part.

For experimental study of potential lateral deviation of cutting edge of lamellar knives, an installation, as well as a method for measuring the lateral deviation under the action of forces arising in the process of cutting semi-finished food products have been developed and manufactured. The need for experimental verification and specification of existing methods for determining P_{kp} and j_H is justified by the features of fastening the lamellar knives in the knife frame, their relatively small thicknesses, special sharpening, as well as the presence of difficult considerable factors.

Schematic diagram of installation is shown in Fig. 1. The installation consists of the following parts: base, knife attachment unit,

tensioning mechanism and units that loading with normal R_2 and lateral R_3 forces.

Knife under the study 2 is fixed in two holders 3 so that its cutting edge faces down to the base 1. The holders have the ability to move in the slots made in the base. This allows using lamellar knives of different lengths in experiments.

The tension of the knife to the value specified by the conditions of the experiment is carried out by means of a screw mechanism 4, connected with one of the movable holders 3.

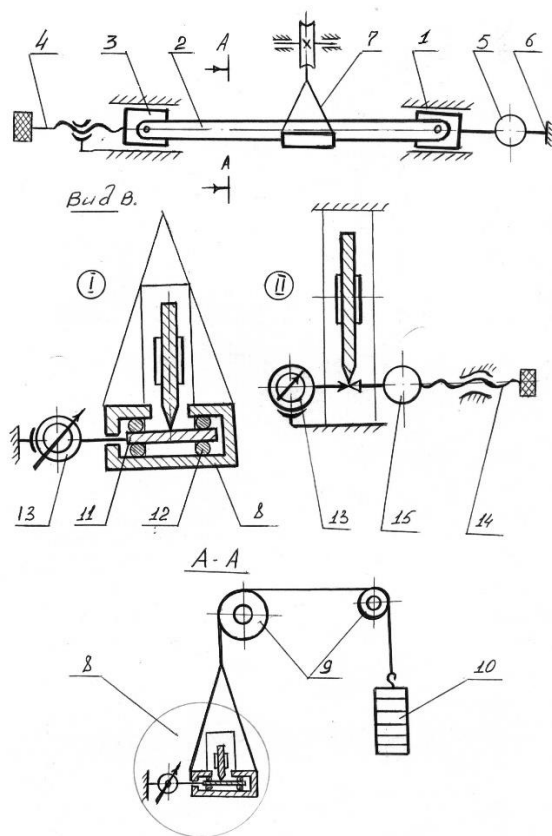

Fig. 1. Schematic diagram of the experimental installation

The value of the knife tension was measured using a strain modifier glued to an elastic ring 5 and located between movable 3 and fixed 6 holder. The measurement scheme and calibration of the strain modifier corresponded to the methods adopted in the practice of strain gauging [3, 4]. The vertical force applied to the knife blade 2 is created using a loading

mechanism 7, consisting of a contact plug 8, blocks 9 and loads 10 suspended on a thread.

In the groove of the plug, there is a board 11, which is in contact with the blade of the lamellar knife 2 and supported through the balls 12 on the horizontal edges of the plug. A 13-hour indicator, the tip of which rests against the movable plate of the contact plug, records the deflection of the knife in the horizontal plane under the action of the applied load.

The lateral force R_3 was applied to the cutting edge of the knife in its middle using a shifter and a screw mechanism 14 with a load-fixing ring strain modifier 15. When conducting research on the stiffness of lamellar knives, the vertical loading unit was dismantled by force R_2 . In this series, indicator 13 recorded the deformation of the samples in the plane of least rigidity.

Fig. 1 shows two variants of load nodes: the first is when measuring stability; the second is when measuring the bending stiffness of a thin lamellar knife.

In consideration of the need to determine, in addition to the initial, also the working stiffness of the lamellar knife, that is, its stability characteristics with the simultaneous action of the forces R_2 and R_3 , one of the series of experiments was carried out using mechanisms 7 and 14. Due to the absence of the possibility of applying the vector R_3 directly to the blade, this load was applied in experiments to the side surface of the knife 2 over the contact plug 8. The possible error of such a replacement was taken into account by reducing the value of the real load R_3 by 20% in the calculations j_p .

In the general case, the stiffness of the lamellar knife was determined from the expression

$$j = \frac{R_3}{y}; \quad (1)$$

If $R_2=0$, then the calculated value corresponds to the initial stiffness j_H . If $R_2 - 0$ and $R_2 < P_{kp}$, then this characteristic is the working rigidity j_p .

The stability of the knife was characterized by the value of the critical force P_{kp} . Under the critical force, we mean the ultimate load acting in the plane of the greatest rigidity of the knife, upon reaching which the knife loses the stability of the flat form of bending [5].

Based on preliminary experiments, a technique for measuring the stability of the cutting edge of thin lamellar knives was developed, which consisted of the following.

First, a series of experiments was carried out to study the initial bending stiffness j_H of knives under the action of the force R_3 . As indicated above, in this series, the loading mechanism 7 was dismantled. The calibration of the annular strain blocks 5 and 15 was carried out on a laboratory press P5 with a stepwise load application. A lamellar knife with certain geometric characteristics was installed in holders 3 to exclude a possible rotation of its cross-section at the attachment points. This was achieved due to special spacers mounted between the blade of the knife and the sides of the holder groove.

After reaching the required force N of the knife tension by the mechanism 4, which was controlled by the secondary device of the strain measurement circuit, the lateral load R_3 was applied by the screw device 14. With a sequential increase in the load R_3 , the indicator 13 recorded the corresponding lateral deviations of the cutting edge in the plane of least rigidity. Empirically, a nonlinear dependence $y=f(R_3)$ has been established, which is primarily explained by the displacement of the point of load application relative to the longitudinal axis of the lamellar knife and the points of its attachment. To unify all experiments in this series, a constant lateral deviation of the cutting edge $y = 1$ mm was chosen, which corresponded to different values of R_3 , depending on the initial parameters of the knife (thickness and width of the blade, length, magnitude and eccentricity of the tension force). Thus, in each experiment of this series,

after reaching $y = 1$ mm, the value of the force R_3 was fixed.

In the next series of experiments, the stability of the cutting edge was studied under the action of the normal component of the total cutting force R and the feed force R_2 . Accordingly, for the possibility of installing the loading mechanism 7, the screw device 14 was dismantled. The knife tension was determined in the way described above. The knife blade 2 was installed in the notch of the plate 11, and after sequential loading with increasing force R_3 the indicator 13 recorded the characteristic lateral deviation of the knife from the position of elastic equilibrium. This deviation corresponded to the onset start of nonlinear growth y when the knife was loaded in equal steps, and corresponded to the moment of loss of stability of the flat shape of the knife bend, i.e. a rather sharp turn of the section of a thin plate knife and a noticeable bending of its cutting edge in the lateral direction.

Experiments with eccentric tension of thin lamellar knives were carried out in the following order. In this series, lamellar knife with the following geometrical parameters was used: length - 250 mm, blade width - 20 mm, thickness - 0.5 mm, eccentricity of the tension line - 5 mm; the diameter of the mounting holes is 4 mm. The same knife, but with a symmetrical arrangement of the tension line ($e=0$), was used to calibrate the strain sensors.

Strain sensors with a base of 5 mm and an active electrical resistance of 50 Ohm were glued to the previously prepared surfaces of the knives. Initially, the calibration knife ($e=0$) was fixed with special holders on the P-5 testing machine and loaded with a step load (after 250 N). The unbalance current of the measuring bridges of each point was amplified by a specific channel of the electronic amplifier and recorded on a 0-0.5 scale of the AVO-63 device. Then a knife with an eccentricity of the tension line $z=5$ mm was installed in the holder of the testing machine. The obtained values of the unbalance current for each knife allows, after comparing them with the calibration data,

to obtain the values of the voltages acting at different points along the width of the blade. The tensile load was increased in the following order: 250, 500, 750, 1000, and 1250 N. Each point of the knife blade corresponded to its own amplifier channel, in which the sensors were calibrated earlier.

Conclusions

Experimental installation and methods have been developed, the measurements of critical force P_{kp} , initial j_H and operational j_p rigidity of thin lamellar knives have been carried out. The calculations and experiments carried out have shown that the thickness δ is the most significant factor influencing the operational rigidity and stability.

Literature:

1. Armarego I.J., Brown R.H. Metal treatment by cutting. - M: Mechanical Engineering, 1977, p. 429.
2. Kapustin I.I. Cutting process and cutting tools in leather and footwear production. - M.: Gizlegprom, 1950, p. 172.
3. Katsnelson M.U. and others. Strain measurement of food production machines. - M.: Mechanical engineering, 1968, p. 230.
4. Strain measurement in mechanical engineering. Reference manual. / edited by Makarov R.A. - M.: Mechanical engineering, 1975, p.261.
5. Timoshenko S.P. Stability of elastic systems.-M.: Gostechizdat, 1955, p.567.