

## EXPERIMENTAL AND ANALYTICAL INVESTIGATING DIE CASTING PROCESS PARAMETERS

VOOTLA ASHOK KUMAR<sup>1</sup>, MD. EZAZ KHAN<sup>2</sup>, MD. ZAHEERUDDIN<sup>3</sup>,  
U. SRIKANTH<sup>4</sup>

<sup>1</sup>Associate Professor & Head of Dept of ME, Mother Theresa College of Engg. & Tech, Peddapalli, Telangana.

<sup>2</sup>Assistant Professor, Dept of ME, Mother Theresa College of Engineering & Technology, Peddapalli, Telangana.

<sup>3</sup>Assistant Professor, Dept of ME, Mother Theresa College of Engg. & Tech, Peddapalli, Telangana.

<sup>4</sup>Assistant Professor, Dept of ME, Mother Theresa College of Engg. & Tech, Peddapalli, Telangana.

### ABSTRACT:

As population increases with the increasing in demand for producing the plastic products in different and sizes with high precision. A case study on plastic electrical switch box is considered to investigate on producing best quality of products to satisfy the demands from the customers. In this thesis, the focus on the optimization of process parameters (temperature, pressure, time) is carried out for injection moulding machine. Quality of characteristic (shrinkage) of the injection moulding product is made by polycarbonate material is calculated by using minitab software for the data obtained. Comparison of the experimental data and analytical results show that there is no significant difference in artificial neural network, and taguchi method was used confidently. An analytical approach is (cfd) discussed by using ansys software and the model of component design, cooling profile, assembling, runner and gate location is done in 3d modelling software creo.

**Key words:** Die Casting, Injection Moulding, Shrinkage, Thaguchi, ANSYS.

### I. INTRODUCTION TO INJECTION MOLDING

**Injection moulding** is a special manufacturing technique used to make parts from plastic materials. In order to accomplish this, the molten plastic is injected into a mold at a high pressure. The mould it is injected into is the inverse design of the desired shape in order to produce the shape in the way it needs to be designed.

**Process:** Injection moulding is a cyclic process of forming plastic into a desired shape by forcing the material under pressure into a cavity. The shaping is achieved by cooling (thermoplastics) or by a chemical reaction (thermoses). It is one of the most common and

versatile operations for mass production of complex plastics parts with excellent dimensional tolerance. It requires minimal or no finishing or assembly operations. In addition to thermoplastics and thermo sets, the process is being extended to such materials as fibres, ceramics, and powdered metals, with polymers as binders.

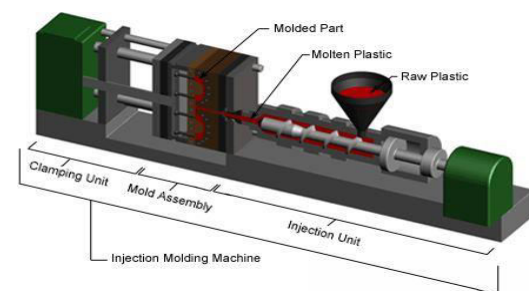

## Injection moulding Machine overview

Injection moulding machines have many components and are available in different configurations, including a horizontal configuration and a vertical configuration. However, regardless of their design, all injection moulding machines utilize a power source, injection unit, mould assembly, and clamping unit to perform the process cycle.

### CAPABILITIES

	Typical	Feasible
<b>Shapes:</b>	Thin-walled:	Flat
	Complex Solid:	Thin-walled:
	Cylindrical Solid:	Cylindrical Thin-walled:
	Cubic Solid:	Cubic
	Complex	
	<b>Part size:</b>	Weight: 0.5 oz - 500 lb
<b>Materials:</b>	Metals	
	Aluminum	
	Lead	Copper
	Magnesium	
	Tin	
<b>Surface finish - Ra:</b>	Zinc	
	32 - 63 $\mu$ in	16 - 125 $\mu$ in
<b>Tolerance:</b>	$\pm$ 0.015 in.	$\pm$ 0.0005 in.
<b>Max wall thickness:</b>	0.05 - 0.5 in.	0.015 - 1.5 in.
<b>Quantity:</b>	10000 - 1000000	1000 - 1000000
<b>Lead time:</b>	Months	Weeks

**Advantages:**

- Scrap can be recycled
- Can produce large parts
- Can form complex shapes
- High strength parts
- Very good surface finish and accuracy
- High production rate
- Low labor cost

**Disadvantages:**

- High tooling and equipment cost
- Limited die life
- Long lead time

**Applications:**

- Engine components, pump components, appliance housing

### Machine specifications

Both hot chamber and cold chamber die casting machines are typically characterized by the tonnage of the clamp force they provide. The required clamp force is determined by the projected area of the parts in the die and the pressure with which the molten metal is injected. Therefore, a larger part will require a larger clamping force. Also, certain materials that require high injection pressures may require higher tonnage machines. The size of the part must also comply with other machine specifications, such as maximum shot volume, clamp stroke, minimum mold thickness, and platen size.

### CASTING DEFECTS

**Hot spots** –thick sections cool slower than other sections causing abnormal shrinkage. Defects such as voids, cracks and porosity are created.

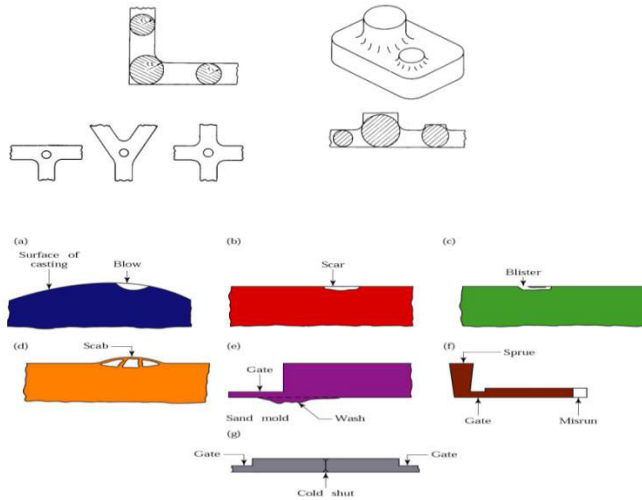

These defects can be eliminated by proper mold preparation, casting design and pouring process.

## II. LITERATURE REVIEW

In the paper by Mohammad Sadeghi, et al<sup>[1]</sup>, die temperature in high-pressure die casting of A380 alloy is optimized by experimental observation and numerical simulation. Ladder frame (one part of the new motor EF7) with a very complicated geometry was chosen as an experimental sample. Die temperature and melt temperature were examined to produce a sound part. Die temperatures at the initial step and the final filling positions were measured and the difference between these values was calculated. ProCAST software was used to simulate the fluid flow and solidification step of the part, and the results were verified by experimental measurements. It is shown that the proper die temperature for this alloy is above 200°C. In the paper by Rajesh Rajkolhe, et al<sup>[2]</sup>, Foundry industries in developing countries suffer from poor quality and productivity due to involvement of number of process parameter. Even in completely controlled process, defect in casting are observed and hence casting process is also known as process of uncertainty which challenges explanation about the cause

of casting defects. In order to identify the casting defect and problem related to casting, the study is aimed in the research work. This will be beneficial in enhancing the yield of casting. Beside this, standardization (optimization) of process parameter for entire cycle of manufacturing of the critical part is intended in the proposed work. This study aims to finding different defects in casting, analysis of defect and providing their remedies with their causes. In this paper an attempt has been made to list different types of casting defects and their root causes of occurrence. This paper also aims to provide correct guideline to quality control department to find casting defects and will help them to analyze defects which are not desired.

## III. INTRODUCTION TO CAD

**Computer-aided design (CAD)** is the use of computer systems (or workstations) to aid in the creation, modification, analysis, or optimization of a design. CAD software is used to increase the productivity of the designer, improve the quality of design, improve communications through documentation, and to create a database for manufacturing. CAD output is often in the form of electronic files for print, machining, or other manufacturing operations. The term **CADD** (for Computer Aided Design and Drafting) is also used.

## INTRODUCTION TO CREO

PTC CREO, formerly known as Pro/ENGINEER, is 3D modeling software used in mechanical engineering, design, manufacturing, and in CAD drafting service firms. It was one of the first 3D CAD modeling applications that used a rule-based parametric system. Using parameters, dimensions and features to capture the behavior of the product, it can optimize the development product as well as the design itself.

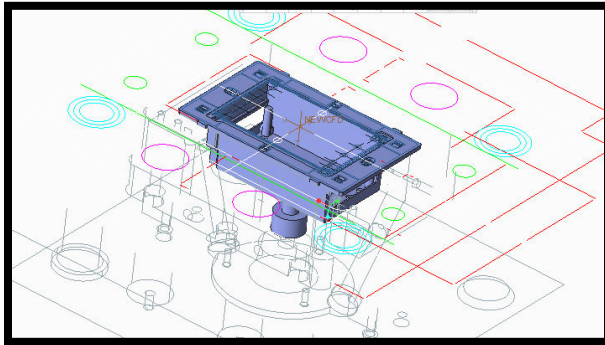

## IV. INTRODUCTION TO FEA

Finite element analysis is a method of solving, usually approximately, certain problems in engineering and science. It is used mainly for problems for which no exact solution, expressible in some mathematical form, is available. As such, it is a numerical rather than an analytical method. Methods of this type are needed because analytical methods cannot cope with the real, complicated problems that are met with in engineering.

## INTRODUCTION TO ANSYS

ANSYS is general-purpose finite element analysis (FEA) software package. Finite Element Analysis is a numerical method of deconstructing a complex system into very small pieces (of user-designated size) called elements. The software implements equations that govern the behaviour of these elements and solves them all; creating a comprehensive explanation of how the system acts as a whole.

## CFD ANALYSIS OF SWITCH BOX

### AT TIME- 8 SEC

→→Ansys → workbench→ select analysis system → fluid flow fluent → double click

→→Select geometry → right click → import geometry → select browse →open part → ok

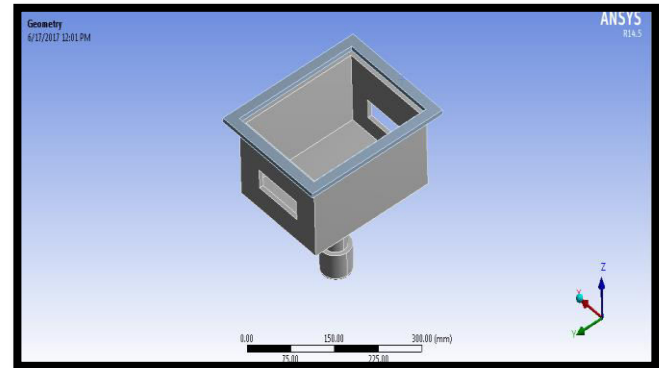

→→ select mesh on work bench → right click  
→edit → select mesh on left side part tree → right click → generate mesh →

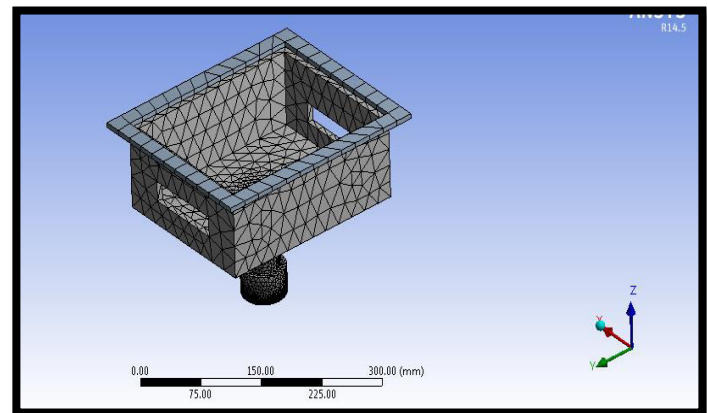

Select faces → right click → create named section → enter name → water inlet

Select faces → right click → create named section → enter name → water outlet

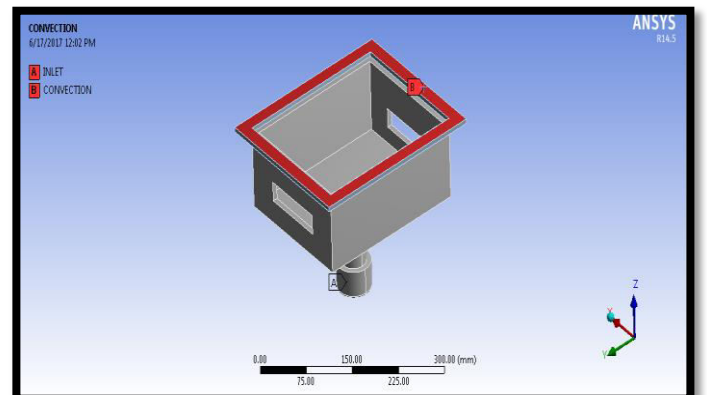



## PRESSURE

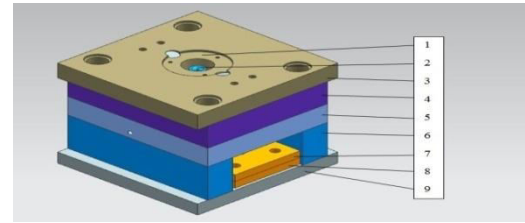
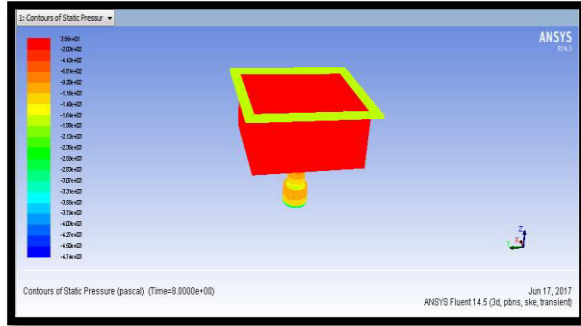

Mould construction

## TEMPERATURE

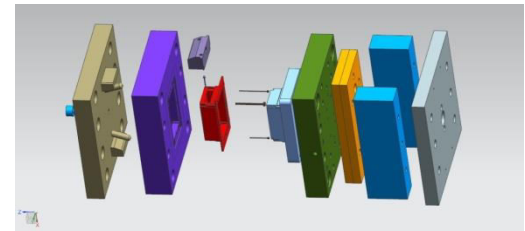
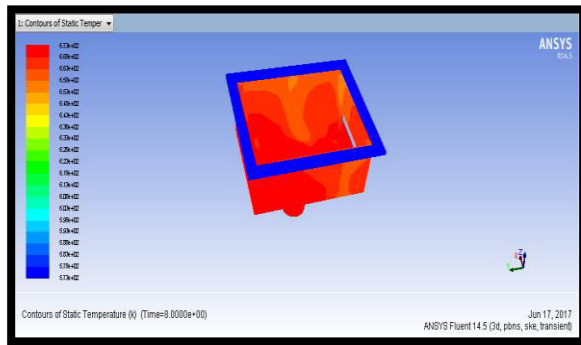

Exploded view

## HEAT TRANSFER COEFFICIENT

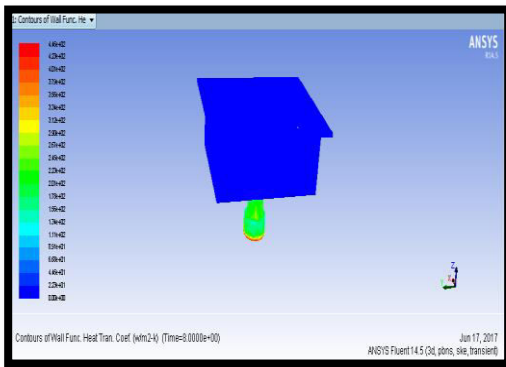

## Manufacturing techniques

The mould core and mould cavity are each mounted to the mould base, it can be manufacturing by using following Machinery.

S.NO	Item of equipment / Machine	capacity	Accuracy achievable
1.	CNC milling	10HP	0.01
2.	EDM sparking	5HP	0.01
3.	Wire cut machine	15HP	0.01
4.	cylindrical grinding	5HP	0.01
3.	Conventional Milling	5HP	0.05
4.	Surface grinding	3HP	0.01
5.	Lathe machine	3hp	0.05
6.	Drilling machines	2HP	0.05
7.	Plastic injection moulding machine	25HP	---

## Using Machinery List

## Assembled Mould



## V. EXPERIMENTAL SETUP

### Mould Design:

Molding or moulding is the process of manufacturing by shaping liquid or pliable raw material using a rigid frame called a mold or matrix.



Injection moulding machine

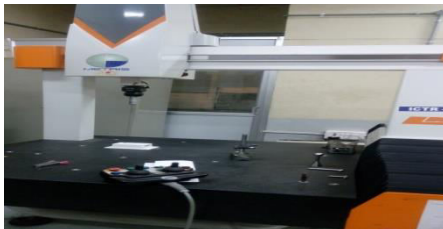

COMPONENTS

TESTING MACHINE

Using CMM Machine to testing the shrinkage values

## VI. INTRODUCTION TO TAGUCHI TECHNIQUE

- Taguchi defines Quality Level of a product as the Total Loss incurred by society due to failure of a product to perform as desired when it deviates from the delivered target performance levels.
- This includes costs associated with poor performance, operating costs (which changes as

a product ages) and any added expenses due to harmful side effects of the product in use.

## RESULTS

	C1	C2	C3	C4	C5	C6	C7
	PRESSURE	TEMPERATURE	CYCLE TIME	SHRINKAGE	SHRINKAGE1	SNRA1	MEAN1
1	50	280	40	0.2430	0.2431	12.2861	0.24305
2	50	290	45	0.2450	0.2452	12.2131	0.24510
3	50	300	50	0.2572	0.2576	11.7878	0.25740
4	55	280	45	0.2601	0.2603	11.6939	0.26020
5	55	290	50	0.2626	0.2627	11.6125	0.26265
6	55	300	40	0.2632	0.2635	11.5893	0.26335
7	60	280	50	0.2695	0.2696	11.3872	0.26955
8	60	290	40	0.2786	0.2789	11.0957	0.27875
9	60	300	45	0.3206	0.3205	9.8821	0.32055

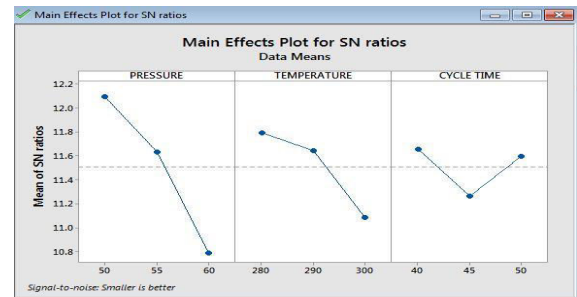

S/N ratio

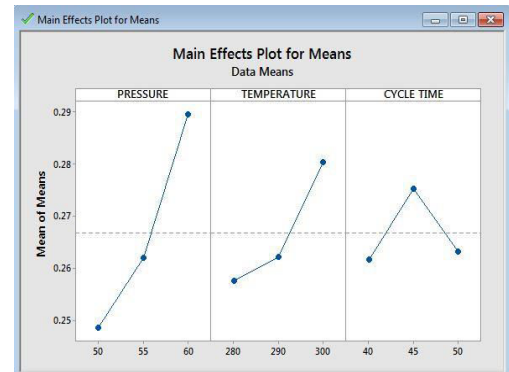

Mean value

**VII. CONCLUSION:** The optimum filling time, injection pressure and die temperature for better solidification of the filling material are analyzed by taking the input parameters molten metal (Pc) temperature, Pressure, and Cycle time. Solidification is done in using thermal and CFD analysis.



# International Conference on Latest Research in Engineering Science

12 & 13 August 2017

[www.ijrugc.org/Conference](http://www.ijrugc.org/Conference)

**From the results, the following conclusions can be made:**

✓ The better solidification occurs at 40 secs injection time, 50 Psi pressure and 280<sup>0</sup>C die temperature. Solidification of molten metal at high pressure and less die temperature increases we get low shrinkage value i.e 0.243.

## REFERENCES

1. Subramanian, N. R., Lin Tingyu and Yak Aik Seng. 2005. Optimizing warpage analysis for an optical housing. *Mechatronics*. 15(1):111–127, 2005). <https://doi.org/10.1016/j.mechatronics.2004.05.004>, Crossref
2. Lucia Zema, Giulia Loreti, Alice Melocchi, Alessandra Maroni and Andrea Gazzaniga. 2012. Injection molding and its application to drug delivery. *Journal of*

*Controlled Release*. 159: 324–331, (2012). <https://doi.org/10.1016/j.jconrel.2012.01.001>, Crossref, CAS

3. Kazmer, D. O. (ed). *Injection Molding*, Encyclopedia of Chemical Processing. Marcel Dekker, Sunggyu (K.B.) Lee, (2005). Google Scholar

4. Strong, A.B. *Plastics: Material and Processing*. (2nd edition). New Jersey: Prentice hall, Inc.,(2000).

5. Alireza Akbarzadeh and Mohammad Sadeghi. Parameter study in plastic injection molding process using statistical methods and IWO algorithm. *International Journal of Modelling and Optimization*. 1(2):141–145, (2011). <https://doi.org/10.7763/IJMO.2011.V1.25>, Crossref