



International Journal for Innovative Engineering and Management Research

A Peer Reviewed Open Access International Journal

www.ijiemr.org

COPY RIGHT



ELSEVIER
SSRN

2021IJIEMR. Personal use of this material is permitted. Permission from IJIEMR must be obtained for all other uses, in any current or future media, including reprinting/republishing this material for advertising or promotional purposes, creating new collective works, for resale or redistribution to servers or lists, or reuse of any copyrighted component of this work in other works. No Reprint should be done to this paper, all copy right is authenticated to Paper Authors

IJIEMR Transactions, online available on 3rdMar2021. Link

[:http://www.ijiemr.org/downloads.php?vol=Volume-10&issue=ISSUE-03](http://www.ijiemr.org/downloads.php?vol=Volume-10&issue=ISSUE-03)

DOI: 10.48047/IJIEMR/V10/I03/13

Title **A FUZZY CONTROLLER BASED MULTI-INPUT HIGH STEP-UP CONVERTER FOR RENEWABLE ENERGY-DRIVE SYSTEMS**

Volume 10, Issue 03, Pages: 94-103.

Paper Authors

K Swetha, R VASANTHI



USE THIS BARCODE TO ACCESS YOUR ONLINE PAPER

To Secure Your Paper As Per **UGC Guidelines** We Are Providing A Electronic Bar Code

A FUZZY CONTROLLER BASED MULTI-INPUT HIGH STEP-UP CONVERTER FOR RENEWABLE ENERGY-DRIVE SYSTEMS

K Swetha

M-tech student Scholar Department of Electrical & Electronics Engineering, Velaga Nageswara Rao College of Engineering, Ponnuru; Guntur (Dt); A.P, India.

R VASANTHI M-Tech

Assistant Professor Department of Electrical & Electronics Engineering, Velaga Nageswara Rao College Of Engineering, Ponnuru; Guntur (Dt); A.P,

ABSTRACT: This paper proposes a multiple input power conditioner topology with Fuzzy controller to integrate intermittent nature of renewable sources such as solar, wind, etc. Solar PV and wind generator are utilized as the primary energy source to meet the load demand and well-regulated output voltage is obtained from the multiple input power conditioners. The high step-up voltage conversion gain, approximately 30 times, can be achieved from the proposed converter. The generated high output voltage is then fed the three-phase inverter driving the PMSM. The control strategies for the proposed multi-input converter and the PMSM drive system will be described. Simulation results show the effectiveness of the proposed multi-input high step-up converter for renewable energy-drive systems under different operating conditions. Performance evaluation of the proposed converter shows that the proposed fuzzy controller tune the parameters of dc/dc converter to obtain well regulated output voltage to the load from the intermittent nature of source.

Keywords- DC/DC converter, Fuzzy logic, Hybrid energy system, Renewable energy, Solar photovoltaic Wind energy.

I INTRODUCTION

Many converter topologies are reported in the literature to provide a good match between different voltage and current characteristic renewable energy resources. In series connected topology [1]. Output voltage and current regulation is difficult for the intermittent nature of renewable sources. Parallel connected topology [2] is inherently complex and results high cost due to multiple number of converters and communication devices between individual converters. There is a supreme need for integrated power converters that are capable of interfacing, and concurrently, controlling several power terminals with low cost and compact structure. The multiple-input dc/dc converter is useful for combining several energy sources whose power capacity and/ or voltage levels are maintained dissimilar [3,4]. An ideal multiple-input power supply could accommodate a variety of sources and combine their advantages automatically, such that the inputs are interchangeable.

Several multiple-input converters have been reported in the literature. A general multiple-input converter, which only utilizes one inductor, has been reported in literature [5]. Characteristic and properties of multiple-input converters are also presented. Power sources can be put in parallel by using the coupled transformer to implement the

multiple input converter and the regulated dc output voltage can be achieved [6]. Multiple input power conditioner to integrate solar-PV and wind energy sources, is proposed to achieve the regulated output voltage and described in detail in this paper [7]. Design of intelligent controller for the power converter is essential to harvest maximum energy form the nonlinear v-i characteristic renewable energy based sources.

In this paper, the multi-input high step-up dc-dc converter for renewable energy PMSM drive system applications is proposed. The multi-input high step-up dc-dc converter topology is introduced for generating the high output voltage of 600Vdc from the low input about 20Vdc. The control strategy based on PI controller for the proposed multi-input high step-up dc-dc converter is described in order to obtain the high output voltage at the desired level. By connecting the three-phase inverter between the proposed converter and the three-phase PMSM, the satisfactory operations of the motor drive system can be achieved under different operating conditions. The indirect vector control based on PI controller is employed in order to regulate the speed of the motor. The overview structure of the proposed multi-input high step-up dc-dc converter for renewable energy-PMSM drive system is shown in Fig. 1. As can be seen, the multi-input renewable energy sources such as fuel cells, PV modules and wind turbines are supplied

to the proposed multi-input converter in order to deliver the power to the PMSM load.

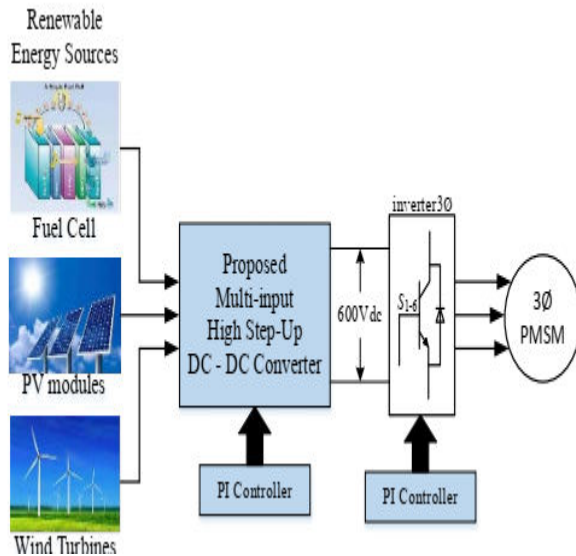

Figure 1. Overview structure of the proposed multi-input high step-up DC-DC converter for renewable energy-PMSM drive system.

2 MULTI-INPUT HIGH STEP-UP DC-DC CONVERTER

The proposed multi-input high step-up dc-dc converter topology is shown in Fig. 2. The proposed high step-up dc-dc converter is the combination between the quadratic boost converter and Cuk converter in order to generate the high voltage conversion ratio. As can be seen, two input sources, V_{in1} and V_{in2} , are used to connect in parallel to the power circuit in order to increase the power, transferring to the load.

The first power source (V_{in1}) is supplied to the first quadratic boost converter which consists of two inductors (L_{11} , L_{12}), two diodes (D_{11} , D_{12}), one capacitor (C_{11}) and one power switch (S_1). Similarly, the second power source (V_{in2}) is connected to the second quadratic boost converter which consists of two inductors (L_{21} , L_{22}), two diodes (D_{21} , D_{22}), one capacitor (C_{21}) and one power switch (S_2). By parallelconnecting the increased power is delivered the resistor load(R) through Cuk converter which comprises of two capacitors (C_2 , C_3), three diodes (D_3 , D_4 , D_5). The output voltage (V_o) is the voltage across the output capacitor (C_o). In order to increase the power to the load the more input sources can be used to supply the proposed multi-input high step-up converter.

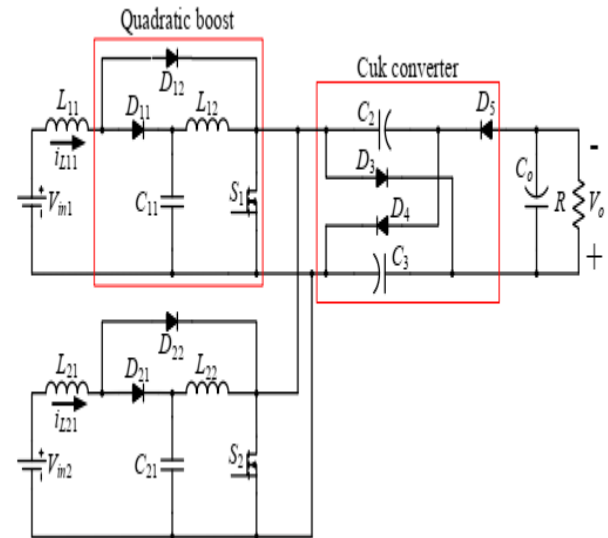

Figure 2. The proposed multi-input high step-up dc-dc converter.

The step-up voltage conversion ratio (M) can be obtained by analyzing the operation modes of the power switch. In [7] the single-input high step-up dc-dc converter with its conversion ratio is described. By considering the proposed multi-input high step-up dc-dc converter, the voltage conversion ratio between the output voltage and each input source voltage can be expressed as

$$M = \frac{V_o}{V_{inn}} = \frac{2}{(1 - D_n)^2} \quad (1)$$

Where D_n is the duty cycle of the power switch associated with the input voltage V_{inn} .

3 CONTROL STRATEGY OF PROPOSED CONVERTER

The control structure of the proposed multi-input high step-up dc-dc converter is presented in Fig. 3. As can be seen the proposed control strategy is based on the PI control technique for the voltage and current regulation. By employing two power sources the duty cycles of the switches (S_1 , S_2) need to be controlled properly in order to achieve the high output voltage at the desired constant level. One PI voltage controller and two PI current controllers are designed in order to generate the proper duty cycles for the power switches.

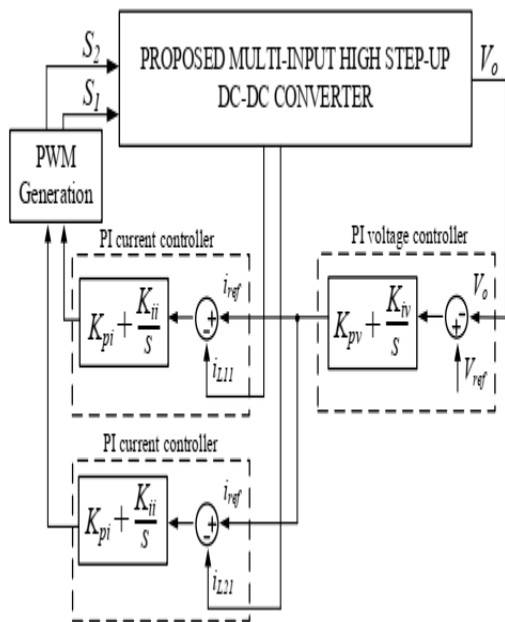

Figure 3. Control scheme of proposed multi-input high step-up dc-dc converter.

As can be seen in Fig. 3, the measured output voltage of the proposed multi-input high step-up converter is compared to the reference output voltage. The PI voltage controller provides the appropriate reference current for the current control loops. Each measured input current will be compared to the reference current. Two PI current controllers are considered because the converter is supplied by two input sources. Therefore, the number of current loops depends on the number of the power sources. In the case that the converter parameters for each input source are designed identically, the control parameters for all the current loops can be designed similarly. Therefore, the parameter gains (K_{pv} , K_{iv} , K_{pi} , K_{ii}) of the PI voltage controller and the PI current controller shown in Fig. 3 are designed as expressed in (2) and (3.3), respectively.

$$K_{pv} = 2\zeta\omega_n C_o - \frac{1}{R}, \quad K_{iv} = \omega_n^2 C_o \quad (2)$$

$$K_{pi} = \frac{2\zeta\omega_{ni} L_{11}}{V_{in1}}, \quad K_{ii} = \frac{\omega_{ni}^2 L_{11}}{V_{in1}} \quad (3)$$

where ζ is the damping ratio, ω_n and ω_{ni} are the natural frequency for the voltage and current loops, respectively.

4. THREE PHASE PMSM DRIVE SYSTEM

Fig. 4 shows the structure of the multi-input high step-up dc-dc converter for three-phase PMSM drive system. The multi power sources with low voltage about 20V-50V are supplied to the proposed multi-input high step-up converter. By employing the proposed control strategy the high constant output voltage of 600V is achieved for the three phase inverter, driving the three-phase PMSM. In order to obtain a high performance PMSM drive, the indirect vector control technique is employed as shown in Fig. 5, consisting of one outer speed-loop PI controller and two inner current loop PI controllers. The measurements of the stator currents and rotor position are needed for the control scheme.

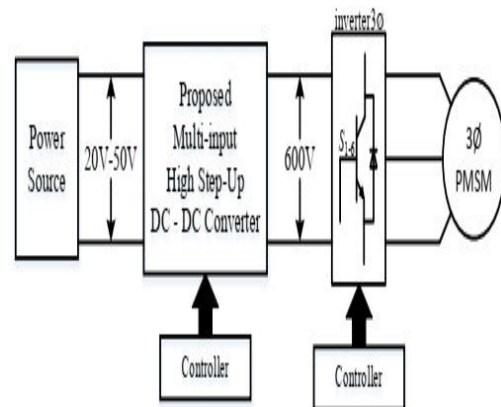

Figure 4. The multi-input converter for PMSM drive system

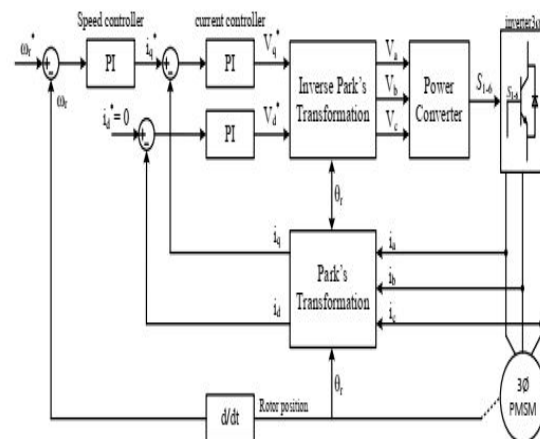

Figure 5. The indirect vector control scheme for the PMSM drive

The block diagrams of the speed controller for the PMSM and the current controllers for both the d-axis and qaxis components of the stator currents are shown in Fig. 6 and 7, respectively.

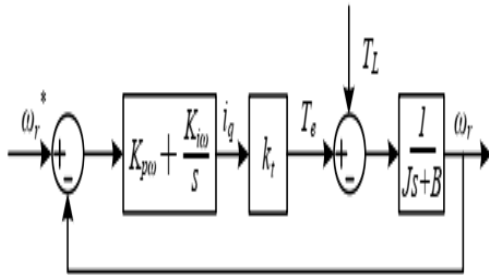

Figure 6. Block diagram of the PI speed controller for the PMSM.

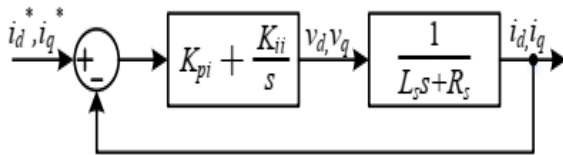

Figure 7. Block diagram of the PI current controller for the PMSM.

Considering Fig. 6 and 7, the torque constant (k_t) and the parameter gains ($K_{p\omega}$, $K_{i\omega}$) for the speed controller and the parameter gains (K_{pi} , K_{ii}) for the current controllers can be obtained by (4) and (5), respectively. It is required that the bandwidth of the current control loop needs to be at least ten times faster than the speed control loop.

$$k_t = \frac{3}{2} \frac{p}{2} \lambda_{pm}, K_{p\omega} = \left(2\zeta\omega_n - \frac{B}{J} \right) \frac{J}{k_t}, K_{i\omega} = \frac{J}{k_t} \omega_n^2 \quad (4)$$

$$K_{pi} = 2\zeta\omega_n L_s - R_s, K_{ii} = L_s \omega_n^2 \quad (5)$$

(5) Proposed work:

A IMPORTANCE OF FUZZY LOGIC

Fuzzy logic is all about the relative importance of precision: use as Fuzzy Logic

Toolbox software with MATLAB technical computing software as a tool for solving problems with fuzzy logic. Fuzzy logic is a fascinating area of research because it does a good job of trading off between significance and precision something that humans have been managing for a very long time.

In this sense, fuzzy logic is both old and new because, although the modern and methodical science of fuzzy logic is still young, the concept of fuzzy logic relies on age-old skills of human reasoning.

B USAGE OF FUZZY LOGIC

Fuzzy logic is a convenient way to map an input space to an output space. Mapping input to output is the starting point for everything. Consider the following examples:

- With information about how good your service was at a restaurant, a fuzzy logic system can tell you what the tip should be.
- With your specification of how hot you want the water, a fuzzy logic system can adjust the faucet valve to the right setting.
- With information about how far away the subject of your photograph is, a fuzzy logic system can focus the lens for you.
- With information about how fast the car is going and how hard the motor is working, a fuzzy logic system can shift gears for you.

To determine the appropriate amount of tip requires mapping inputs to the appropriate outputs. Between the input and the output, the preceding figure shows a black box that can contain any number of things: fuzzy systems, linear systems, expert systems, neural networks, differential equations, interpolated multidimensional lookup tables, or even a spiritual advisor, just to name a few of the possible options. Clearly the list could go on and on.

Of the dozens of ways to make the black box work, it turns out that fuzzy is often the very best way. As Lotfi Zadeh, who is considered to be the father of fuzzy logic, once remarked: "In almost every case you can build the same product without fuzzy logic, but fuzzy is faster and cheaper".

C CONVENIENCE OF FUZZY LOGIC

Fuzzy logic is not a cure-all. When should you not use fuzzy logic? The safest statement is the first one made in this introduction: fuzzy logic is a convenient way to map an input space to an output space. Fuzzy logic is the codification of common sense — use common sense when you implement it and which will probably make the right decision. Many controllers, for example, do a fine job without using fuzzy logic. However, it takes the time to become familiar with fuzzy logic, it can be a very powerful tool for dealing quickly and efficiently with imprecision and nonlinearity.

D The Fuzzy Logic Concept

Fuzzy logic arose from a desire to incorporate logical reasoning and the intuitive decision making of an expert operator into an automated system. The aim is to make decisions based on a number of learned or predefined rules, rather than numerical calculations. Fuzzy logic incorporates a rule-based structure in attempting to make decisions. However, before the rule-based can be used, the input data should be represented in such a way as to retain meaning, while still allowing for manipulation. Fuzzy logic is an aggregation of rules, based on the input state variables condition with a corresponding desired output. A mechanism must exist to decide on which output, or combination of different outputs, will be used since each rule could conceivably result in a different output action.

Fuzzy logic can be viewed as an alternative form of input=output mapping. Consider the input premise, x , and a particular qualification of the input x represented by A_i . Additionally, the corresponding output, y , can be qualified by expression C_i . Thus, a fuzzy logic representation of the relationship between the input x and the output y could be described by the following:

R1: IF x is A_1 THEN y is C_1

R2: IF x is A_2 THEN y is C_2

.....

Rn: IF x is A_n THEN y is C_n

where x is the input (state variable), y is the output of the system, A_i are the different fuzzy variables used to classify the input x and C_i are the different fuzzy variables used to classify

the output y . The fuzzy rule representation is linguistically based.

Thus, the input x is a linguistic variable that corresponds to the state variable under consideration. Furthermore, the elements A_i are fuzzy variables that describe the input x . Correspondingly, the elements C_i are the fuzzy variables used to describe the output y . In fuzzy logic control, the term “linguistic variable” refers to whatever state variables the system designer is interested in. Linguistic variables that are often used in control applications include Speed, Speed Error, Position, and Derivative of Position Error. The fuzzy variable is perhaps better described as a fuzzy linguistic qualifier. Thus the fuzzy qualifier performs classification

(qualification) of the linguistic variables. The fuzzy variables frequently employed include Negative Large, Positive Small and Zero. Several papers in the literature use the term “fuzzy set” instead of “fuzzy variable”, however; the concept remains the same. Table 4.1 illustrates the difference between fuzzy variables and linguistic variables. Once the linguistic and fuzzy variables have been specified, the complete inference system can be defined. The fuzzy linguistic universe, U , is defined as the collection of all the fuzzy variables used to describe the linguistic variables.

i.e. the set U for a particular system could be comprised of Negative Small (NS), Zero (ZE) and Positive Small (PS). Thus, in this case the set U is equal to the set of [NS, ZE, PS]. For the system described by, the linguistic universe for the input x would be the set $U_x = A_1 A_2 \dots A_n$. Similarly,

TABLE 1 Fuzzy and linguistic variables

Linguistic Variables	Fuzzy Variables (Linguistic Qualifiers)
Speed error (SE)	Negative large (NL)
Position error (PE)	Zero (ZE)
Acceleration (AC)	Positive medium (PM)
Derivative of position error (DPE)	Positive very small (PVS)
Speed (SP)	Negative medium small (NMS)

The linguistic universe for the output y would be the set $U_y = \{C_1, C_2, \dots, C_n\}$.

The Fuzzy Inference System (FIS) The basic fuzzy inference system (FIS) can be classified as: Type 1 Fuzzy Input Fuzzy Output (FIFO)

Type 2 Fuzzy Input Crisp Output (FICO)

Type 2 differs from the first in that the crisp output values are predefined and, thus, built into the inference engine of the FIS. In contrast, type 1 produces linguistic outputs. Type 1 is more general than type 2 as it allows redefinition of the response without having to redesign the entire inference engine. One drawback is the additional step required, converting the fuzzy output of the FIS to a crisp output. Developing a FIS and applying it to a control problem involves several steps:

1. Fuzzification
2. Fuzzy rule evaluation (fuzzy inference engine)
3. Defuzzification.

The total fuzzy inference system is a mechanism that relates the inputs to a specific output or set of outputs. First, the inputs are categorized linguistically (fuzzification), then the linguistic inputs are related to outputs (fuzzy inference) and, finally, all the different outputs are combined to produce a single output (defuzzification). Figure 8 shows a block diagram of the fuzzy inference system.

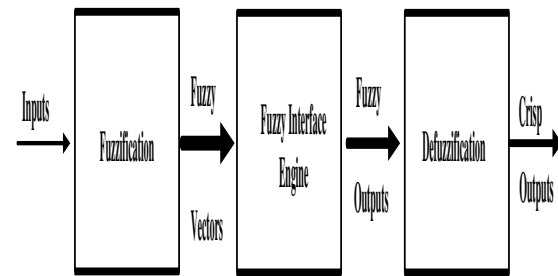

Fig .8 Fuzzy inference system.

E Fuzzification:

Fuzzy logic uses linguistic variables instead of numerical variables. In a control system, error between reference signal and output signal can be assigned as Negative Big (NB), Negative Medium (NM), Negative Small (NS), Zero (ZE), Positive small (PS), Positive Medium (PM), Positive Big (PB). The triangular membership function is used for fuzzifications. The process of fuzzification convert numerical variable (real number) to a linguistic variable (fuzzy number). Simply the process of converting a numerical variable (real number) convert to a linguistic variable (fuzzy number) is called fuzzification.

F.Defuzzification:

The rules of fuzzy logic controller generate required output in a linguistic variable (Fuzzy Number), according to real world requirements; linguistic variables have to be transformed to crisp output (Real number). This selection of strategy is a compromise between accuracy and computational intensity.

The rules of FLC generate required output in a linguistic variable (Fuzzy Number), according to real world requirements, linguistic variables have to be transformed to crisp output (Real number).

Database: the Database stores the definition of the membership Function required by fuzzifier and defuzzifier.

Rule Base: the elements of this rule base table are determined based on the theory that in the transient state, large errors need coarse control, which requires coarse in-put/output variables; in the steady state, small errors need fine control, which requires fine input/output variables. Based on this

the elements of the rule table are obtained as shown in Table 4.2, with 'Vdc' and 'Vdc-ref' as inputs.

G FUZZY LOGIC CONTROLLER

Fuzzy logic is a method of rule-based decision making used for expert systems and process control that emulates the rule-of-thumb thought process used by human beings. The basis of fuzzy logic is fuzzy set theory which was developed by Lotfi Zadeh in the 1960s. Fuzzy set theory differs from traditional Boolean (or two-valued) set theory in that partial membership in a set is allowed. Traditional Boolean set theory is two-valued in the sense that a member belongs to a set or does not and is represented by 1 or 0, respectively. Fuzzy set theory allows for partial membership, or a degree of membership, which might be any value along the continuum of 0 to 1. A linguistic term can be defined quantitatively by a type of fuzzy set known as a membership function. The membership function specifically defines degrees of membership based on a property such as temperature or pressure. With membership functions defined for controller or expert system inputs and outputs, the formulation of a rule base of IF-THEN type conditional rules is done. Such a rule base and the corresponding membership functions are employed to analyze controller inputs and determine controller outputs by the process of fuzzy logic inference. By defining such a fuzzy controller, process control can be implemented quickly and easily. Many such systems are difficult or impossible to model mathematically, which is required for the design of most traditional control algorithms. In addition, many processes that might or might not be modeled mathematically are too complex or nonlinear to be controlled with traditional strategies. However, if a control strategy can be described qualitatively by an expert, fuzzy logic can be used to define a controller that emulates the heuristic rule-of-thumb strategies of the expert. Therefore, fuzzy logic can be used to control a process that a human can control manually with expertise gained from experience. The linguistic control rules that a human expert can describe in an intuitive and general manner can be directly translated to a rule base for a fuzzy logic controller.

Figure 9 shows the internal structure of the control circuit. The control scheme consists of Fuzzy

controller, limiter, and three phase sine wave generator for reference current generation and generation of switching signals. The peak value of reference currents is estimated by regulating the DC link voltage. The actual capacitor voltage is compared with a set reference value. The error signal is then processed through a Fuzzy controller, which contributes to zero steady error in tracking the reference current signal. A fuzzy controller converts a linguistic control strategy into an automatic control strategy, and fuzzy rules are constructed by expert experience or knowledge database. Firstly, input voltage V_{dc} and the input reference voltage V_{dc-ref} have been placed of the angular velocity to be the input variables of the fuzzy logic controller. Then the output variable of the fuzzy logic controller is presented by the control Current I_{max} . To convert these numerical variables into linguistic variables, the following seven fuzzy levels or sets are chosen as: NB (negative big), NM (negative medium), NS (negative small), ZE (zero), PS (positive small), PM (positive medium), and PB (positive big) as shown in Figure 10.

The fuzzy controller is characterized as follows:

- 1) Seven fuzzy sets for each input and output;
- 2) Fuzzification using continuous universe of discourse;
- 3) Implication using Mamdani's 'min' operator;
- 4) De-fuzzification using the 'centroid' method.

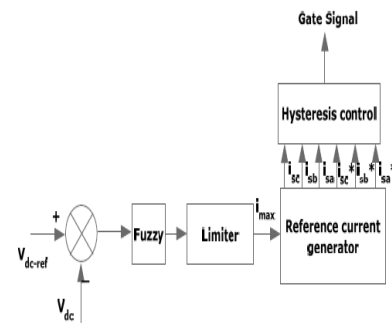

Fig.9. Conventional fuzzy controller

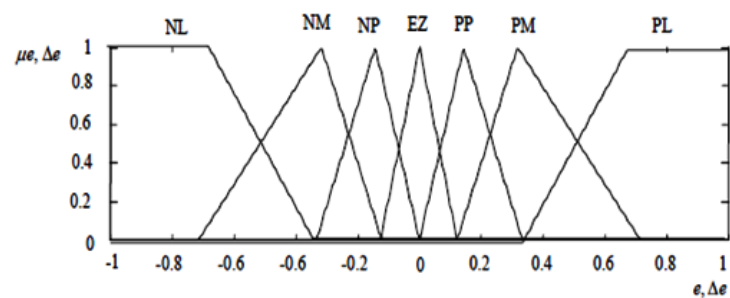
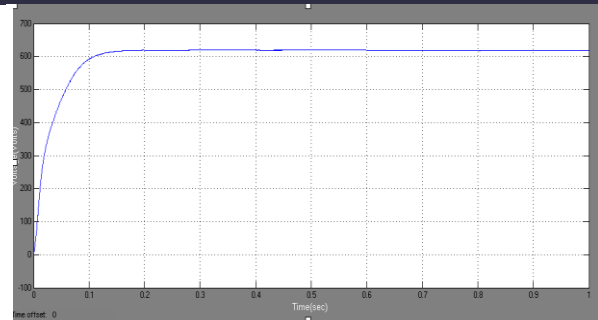

Fig.10. Input V_{dc} normalized membership function;

Table 2: Rules for Fuzzy System

Δe \ e	NL	NM	NS	EZ	PS	PM	PL
NL	NL	NL	NL	NL	NM	NS	EZ
NM	NL	NL	NL	NM	NS	EZ	PS
NS	NL	NL	NM	NS	EZ	PS	PM
EZ	NL	NM	NS	EZ	PS	PM	PL
PS	NM	NS	EZ	PS	PM	PL	PL
PM	NS	EZ	PS	PM	PL	PL	PL
PL	NL	NM	NS	EZ	PS	PM	PL



(b) Voltage

(6) SIMULATION RESULTS

Fig 12 Performance of the multi-input converter with the PMSM drive operating at different speeds.

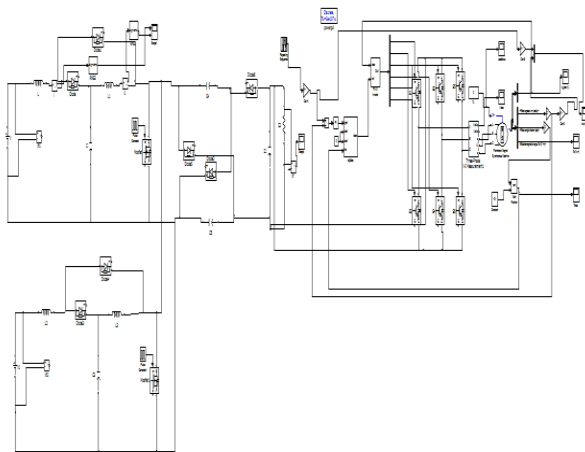
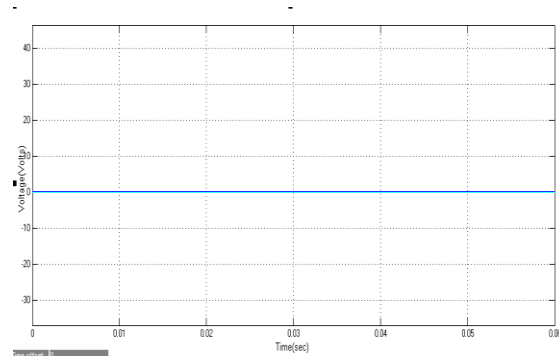
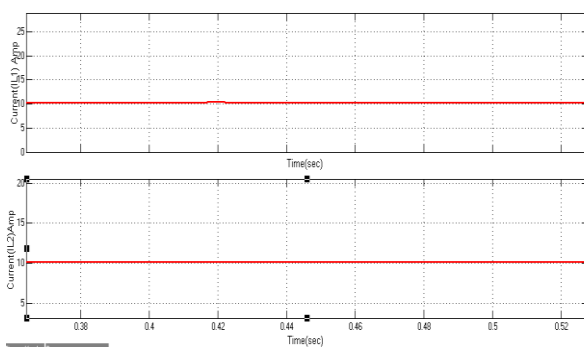

Fig 11 simulink diagram of proposed system



(a) PMSM Vabc Voltage



(a) Inductor Currents

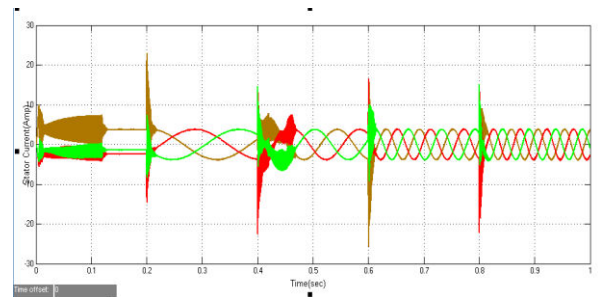

(b) PMSM Iabc Stator current

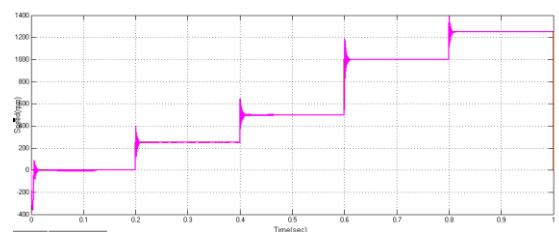

(c) PMSM Speed

Figure 13. Performance of the PMSM operating at different speeds.

In order to demonstrate the performance of the multi input high step-up converter with its control strategy for the PMSM drive system, the various system operating conditions have been investigated. Fig. 12 and 13 show the simulation results obtained from the multi-input converter and the PMSM, respectively, under the variation in speeds with no-load torque. The input voltages for both power sources of the multi-input converter are defined at 20V. As can be seen in Fig. 12 and 13, the multi-input converter with its control strategy can step the low input voltage of 20V up to desired output voltage level of 600V.

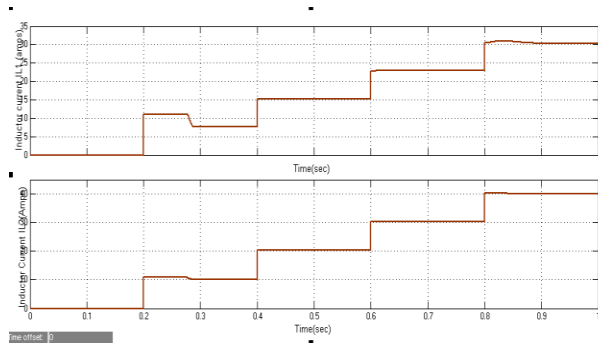

(a) Inductor Currents

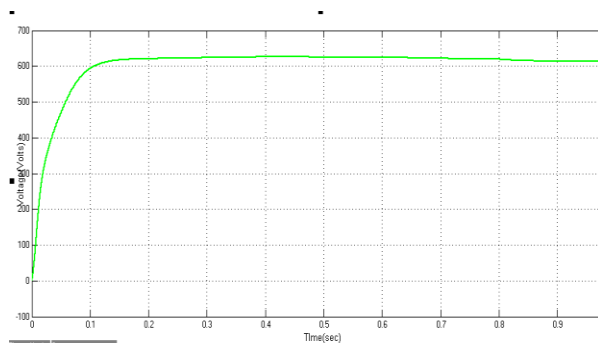

(b) Voltage

Figure 14. Performance of the multi-input converter with the PMSM drive operating at different speeds.

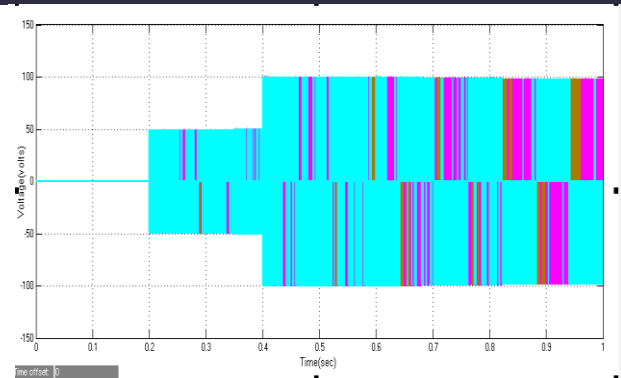

(a) PMSM Vabc Voltage

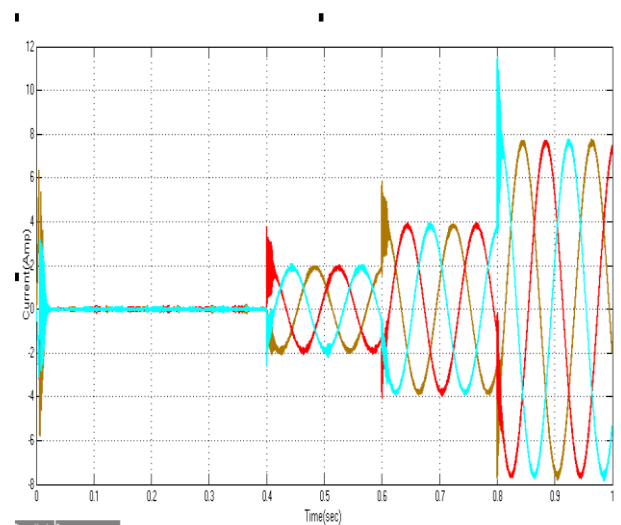

(b) PMSM Iabc Stator current

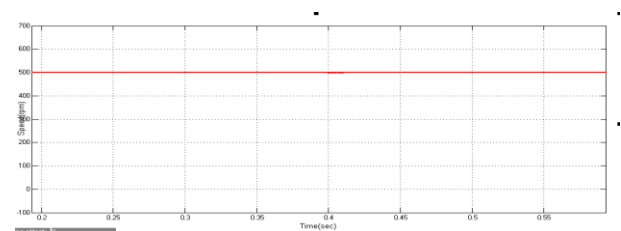

(a) PMSM Speed

Figure 15. Performance of the PMSM operating at different speeds.

Fig. 14 and 15 present the performance of the multi-input converter for the PMSM drive system, operating with a variation of applied load torque. Under no-load torque operation, the converter output voltage is controlled at the command level of 600V and the input currents are about 10A. The PMSM is regulated at 500rad/s with the small three-phase motor currents. A 1Nm load torque is

applied to the motor at the time $t = 4s$. Consequently, the speed of PMSM decreases during transient operation.

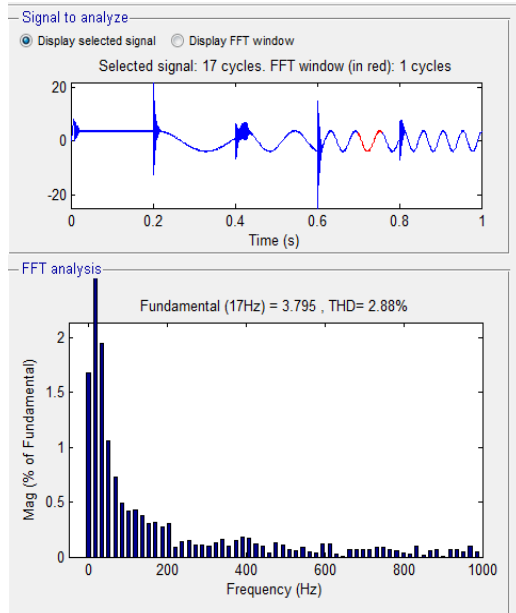

Fig 16 THD of the PI controller based proposed system

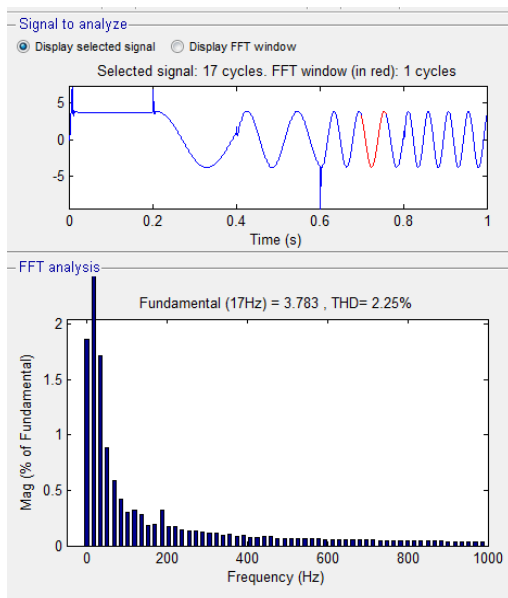

Fig 17 THD of the fuzzy controller based proposed system

(7) CONCLUSION

This paper has been proposed the multi-input high stepup dc-dc converter for renewable energy-PMSM drive systems. The multi-input

configuration is introduced to the high step-up dc-dc converter, providing the higher power to the load with very high voltage conversion ratio, approximately 30 times. The proposed multi-input topology is suitable for the renewable energy applications, where the high output voltage and the high power are needed. The control strategy for the proposed multi-input converter is based on the PI &Fuzzy controller, consisting one voltage-control loop and multi current-control loops. The designed controller can regulate the output voltage at the desired level of 600V. The three-phase inverter is connected to the proposed multiinput converter in order to drive the three-phase PMSM. The PI &Fuzzy speed controller and the PI &Fuzzy current controllers are designed to control the speed and torque of the PMSM. The simulation results show that the proposed multi-input high step-up dc-dc converter for the three-phase PMSM drive system can achieve the satisfactory performance under various system operating conditions.

REFERENCES

- [1] K. Tseng, C. Huang and W. Shih, "A High Step-Up Converter With a Voltage Multiplier Module for a Photovoltaic System," in IEEE Transactions on Power Electronics, vol. 28, no. 6, pp. 3047-3057, June 2013.
- [2] N. Husna, A.W., Siraj, S.F. and M. Z. Ab Muin, "Modeling of DCDC converter for solar energy system applications," 2012 IEEE Symposium on Computers & Informatics (ISCI), Penang, pp. 125-129, 2012.
- [3] R. Gules, L. L. Pfitscher and L. C. Franco, "An interleaved boost DCDC converter with large conversion ratio," 2003 IEEE International Symposium on Industrial Electronics, Rio de Janeiro, Brazil, vol. 1, pp. 411-416, 2003.
- [4] Qun Zhao and F. C. Lee, "High-efficiency, high step-up DC-DC converters," in IEEE Transactions on Power Electronics, vol. 18, no. 1, pp. 65-73, Jan. 2003.
- [5] S. Khwan-on and K. Kongkanjana, "The control of a multi-input boost converter for renewable energy system applications," 2017 International Electrical Engineering Congress (iEECON), Pattaya, Thailand, pp.1-4, March 2017.
- [6] N. Smith and R. McCann, "Analysis and simulation of a multiple input interleaved boost converter for renewable energy applications," IEEE 36th International Telecommunications Energy Conference (INTELEC), Vancouver, BC, pp. 1-7, 2014.
- [7] S. Vatcharasukpo and S. Khwan-on. "A High Step-Up DC-DC Converter for Renewable Energy System Applications" World Academy of Science, Engineering and Technology Electrical and Computer Engineering Vol:1, No:5, 1-6 PP, 2014.