



# International Journal for Innovative Engineering and Management Research

A Peer Reviewed Open Access International Journal

www.ijiemr.org

## COPY RIGHT

**2017 IJIEMR.** Personal use of this material is permitted. Permission from IJIEMR must be obtained for all other uses, in any current or future media, including reprinting/republishing this material for advertising or promotional purposes, creating new collective works, for resale or redistribution to servers or lists, or reuse of any copyrighted component of this work in other works. No Reprint should be done to this paper, all copy right is authenticated to Paper Authors

IJIEMR Transactions, online available on 27<sup>th</sup> Nov 2017. Link

[:http://www.ijiemr.org/downloads.php?vol=Volume-6&issue=ISSUE-11](http://www.ijiemr.org/downloads.php?vol=Volume-6&issue=ISSUE-11)

Title: **POWER FACTOR CORRECTION USING BRIDGELESS BOOST AC-DC CONVERTER FED INDUCTION MOTOR DRIVE**

Volume 06, Issue 11, Pages: 292–301.

Paper Authors

**G.MURALI KRISHNA, G.SRI HARSHA**

MVR College of Engineering and Technology, Paritala; Krishna (DT); A.P, India.



USE THIS BARCODE TO ACCESS YOUR ONLINE PAPER

To Secure Your Paper As Per **UGC Guidelines** We Are Providing A Electronic Bar Code

## POWER FACTOR CORRECTION USING BRIDGELESS BOOST AC-DC CONVERTER FED INDUCTION MOTOR DRIVE

<sup>1</sup>G.MURALI KRISHNA, <sup>2</sup>G.SRI HARSHA

<sup>1</sup>M-tech Student Scholar, Department of E.E.E, MVR College of Engineering and Technology, Paritala; Krishna (DT); A.P, India.

<sup>2</sup>Assistant Professor, Department of E.E.E, MVR College of Engineering and Technology, Paritala; Krishna (DT); A.P, India.

**Abstract:** In this work a bridgeless Power Factor Correction (PFC) boost ac-dc converter is proposed to reduce harmonic current of an induction motor. The aim of the work is to improve the input power factor of induction motor drive. Conventional bridged PFC topology is replaced by bridgeless PFC topology. Conventional VSI fed induction motor suffers from the high conduction loss in the input rectifier-bridge. The bridgeless boost converter is used to avoid conduction loss. Higher efficiency can be achieved by using the bridgeless boost topology. The simulation results with bridgeless boost converter show that there is an improvement in power factor.

**Key Words:** Bridge boost ac-dc converter, Continuous Conduction Mode, Power Factor Correction (PFC), Bridgeless boost ac-dc converter, Total Harmonic Distortion (THD), Induction Motor

### I. INTRODUCTION

There are two factors that provide the quantitative measure for the quality of power supply in an electrical network. They are the Power Factor and Total Harmonic Distortion (THD). The Power Factor (PF) of the system predominantly decides the amount of useful power to be consumed by an electric network [1]. The reward of Power Factor Correction includes less energy and distortion losses, reduced losses in the system at the time of distribution, improved voltage regulation and can supply the power demand. This paper deals with the Power Factor Correction thereby improving the Power Quality at ac mains. The input bridge rectifier in the conventional Power Factor Corrector converters reduces the efficiency of the converter. In order to reduce the losses associated with the rectifier, the rapidly developing power electronic strategies

are employed [2] [3]. Some of the limitations are Stresses across the switch, since a single switch for both the period of conduction, conduction losses, etc [4]. The induction motor has well-known advantages of simple construction, reliability, ruggedness and low cost. While comparing with dc motor, it can be used in hazardous environment since there are no problems with spark and corrosion [5-7]. In the past Induction motors and synchronous motors are employed mainly for constant speed applications because variable speed application of this drives are either too expensive or had very poor efficiency. But with development of semiconductor converters employing thyristors, power transistors, IGBTs and GTOs they are widely used now a day's [8]. The present proposal aims at minimizing ripples in DC bus voltage and the peak current flowing

through the rectifier diodes by interleaving of bridgeless converters [9]. The converter improves power factor and VFD employed will reduce the power consumption. It can be employed in applications requiring operation at variable speeds ranging from small appliances to the medium power applications [10]. The Active Front End Inverter refers to the power converter system consisting of the line-side converter with active switches such as MOSFETs, the dc link capacitor bank, and the load-side inverter. An improved front end converter was proposed in [11-13]. But this converter is being replaced by interleaved bridgeless boost converter. The line-side converter normally functions as a rectifier also known as PWM rectifier, since it can be switched using a suitable pulse width modulation technique.

## **II. BRIDGE TYPE BOOST PFC CONVERTER**

For the active Power Factor Correction in ac-dc converters we mostly use dc-dc converter. Among all the basic dc-dc converters, the boost converter is more effective than others in PFC applications. Mostly we use dc-dc boost converter with the output of ac-dc converter to get power factor approaching unity. This process also has simplicity, higher conversion efficiency and lower harmonic distortion as compared to the other converters. The dc-dc converter which steps up the voltage is known as boost dc-dc converter. This type of converters requires some energy storage element such as inductors, along with switching elements; diodes and transistors. Most of the times the boost PFC type ac-dc converter do not require much filtering because it gets continuous current from the ac source. Only a simple filter

consisting of a capacitor can fulfill the requirement of filtering for such converter. However, higher level of filtering is required for all other converters such as buck and buck-boost. This is because their input current is pulsating type. So the BOOST converter used for PFC is our main focus in this paper. In this paper we will analyze different operating modes and controlling of this topology to obtain the best possible results with this topology. We will also do some modifications in the structure of conventional boost PFC and its control. In this PFC technique bridge rectifier is followed by a Boost converter. We can control the output dc voltage and the power factor by controlling this boost converter. This converter can operate in different regions that are defined on the basis of inductors current behavior. The regions in which a boost converter can operate are the continuous conduction mode (CCM) and discontinuous conduction mode (DCM). In DCM, the inductor current ripples are very high due to which power losses are high so the DCM operation restricts it to low power applications [13]. At the other end in CCM, the inductor current ripples are very small due to which power losses are low, which makes it optimal for medium and high power applications. Moreover in case of DCM we just have to use the voltage control loop but in case of CCM operation of boost PFC converter, we have to use both the current and the voltage control loops. The current control loop is used to force the input line current to follow the input line voltage while the voltage control loop is used to regulate the output dc voltage. DCM operation offers a number of advantages such as inherited power factor correction and simple control of power electronic switches. Moreover it also

reduces reversed recovery losses of the diode due to soft turn off of freewheeling diode. On the other hand, in CCM, complex controller is required to control voltage and current simultaneously but the inductor current ripples are very low. Therefore, at the cost of complex control strategy the size of inductor is reduced. Whereas, DCM requires a high-quality boost inductor for extremely high current ripples. The control of this system is divided into two loops; the output voltage control loop and the input current control loop. Fig.1 shows the block diagram of the control strategy in which one loop calculates the voltage error and the other loop calculates the current error. Both of these errors are then fed to PI controller.

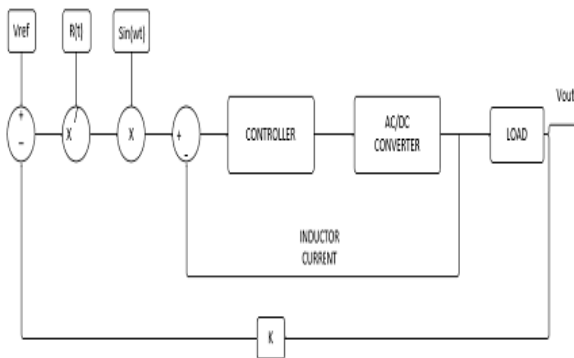

Fig.1. Block diagram of the control methodology of Boost PFC converter

As discussed earlier, there are two states of this system; capacitor voltage and inductor current. In this particular system both of these states need to be controlled but there is only one control input available for controlling the system so this is an under actuated electric system.

### III. CONTROLLER AND RESISTOR OBSERVER

The control strategy of Boost PFC AC-DC Converter is designed in such a way that, first it calculates the error between the reference and

the output voltage and then this DC value is converted to the reference current that follows the input voltage by multiplying it with the rectified sinusoidal wave and dividing it with the load resistance. Now this reference current is then subtracted from the actual inductor current to get an error, which is then fed to the controller to achieve our goal of tracking. Fig.2 is the schematic diagram of Boost PFC with Diode Bridge and controller. In equation (1) PI controller is shown which is applied on the error obtained by subtraction of reference current  $i_{ref}$  from inductor current  $i_L$ . In equation (2) the reference current  $i_{ref}$  waveform is generated using required output DC voltage, connected load and the sinusoidal waveform of AC voltage.  $V_{ref}$  is the desired output voltage of the converter and  $V_o$  is the actual output voltage. The variable resistive load is denoted by  $R(t)$  and  $k_1, k_2$  are the gains.

$$u = K_p(i_{ref} - i_L) + K_i \int (i_{ref} - i_L) dt \quad (1)$$

$$i_{ref} = \frac{(V_{ref} - k_1 V_o)}{k_2 R(t)} |\sin(\omega t)| \quad (2)$$

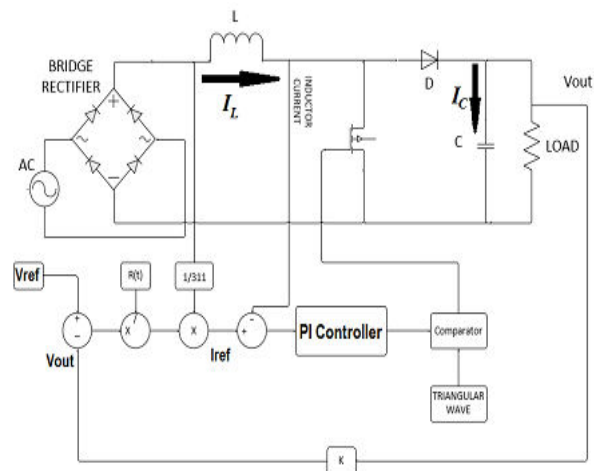

Fig.2. Schematic diagram of Boost PFC converter with control diagram

As output of the controller has to switch the power electronic switch of boost converter so we have to convert  $u$  into PWM. In this paper, fixed frequency Sinusoidal PWM (SPWM) is used. As this converter is designed for variable switching load so we have to observe the value of load. As the equation of controller totally depend upon the generation of reference signal and reference signal depends upon connected load so value of load must be known. The load observer can be described as:

$$R(t) = \frac{V_{ref}}{I_o} \quad (3)$$

$V_{ref}$  is reference dc voltage and  $I_o$  is defined as:

$$I_o = (i_L - i_C) \bar{u} \quad (4)$$

$i_L$  is the current passing through inductor and  $i_C$  is the current passing through capacitor.

$$i_C = C \frac{dV_C}{dt} \quad (5)$$

## IV. BRIDGELESS BOOST PFC CONVERTER

As the requirement of high power quality is always there so it is an active research area. Therefore, efforts are always made to get higher power factor and lower total harmonic distortion. Previously, boost power factor correction converter has been widely used because of its simplicity, inherent PFC capability and high output power. But this topology has harmonic distortions and low efficiency due to number of semiconductor switches in the line. To lower the losses and to increase the efficiency single phase bridgeless boost PFC converter was introduced [12]-[13]. In the literature bridgeless boost AC-DC converter is also called as dual-boost converter.

In this converter the conduction losses are reduced due to reduction in the semiconductor switches in the path of current. Bridgeless boost PFC converter is highly efficient topology because in this topology bridge-rectifier is omitted and there are only two nonlinear switches in any given conduction path. This bridgeless topology consists of two boost converter circuits. The control strategy is same as Boost PFC converter, but the only difference is during positive half cycle one boost circuit is used and during negative half cycle second boost circuit is used. Where as in boost PFC, first negative half cycle is converted to positive half cycle by using bridge rectifier and then it is fed to the boost converter. Fig.3 shows the schematic diagram of bridgeless boost PFC converter.

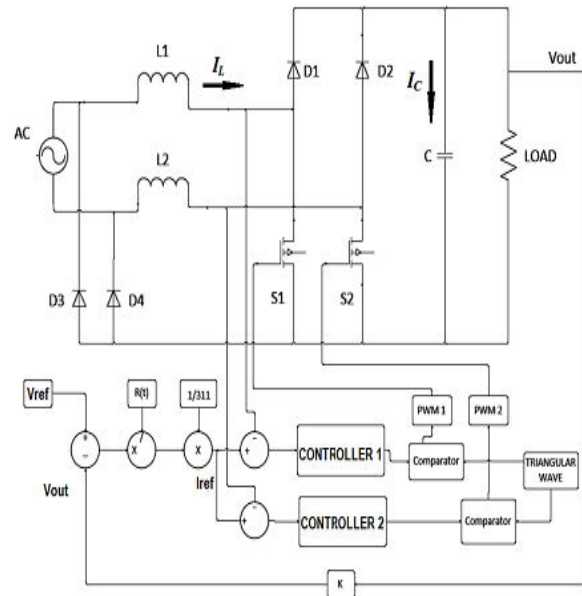

Fig.3. Schematic diagram of Bridgeless Boost PFC converter

### A. Working principle of Bridgeless PFC converter

This bridgeless topology is actually made from two converters that's why it is also known as dual boost converter. In conventional boost

converter DC is fed to the inductor but in bridgeless topology AC is directly fed between the inductors of two DC converters. There are four modes of operation of bridgeless power factor correction converter. Positive half cycle of the ac line voltage consists of Modes I and II while negative half cycle of ac line voltage consists of modes III and IV.

### 1) Positive half cycle

For the duration of the positive half cycle of the ac line voltage, the current follows the path of first dc/dc boost converter; L1-D1-S1-D4. Diode D4 completes the circuit without including the inductor L2 and connecting the output ground. Furthermore, there are two modes of operation of positive half cycle.

Fig.4 shows the working principle of mode I. The switch S1 is turned on to store the energy in inductor L1. The path  $V_{in}$ -L1-S1-D4 is followed in this mode.

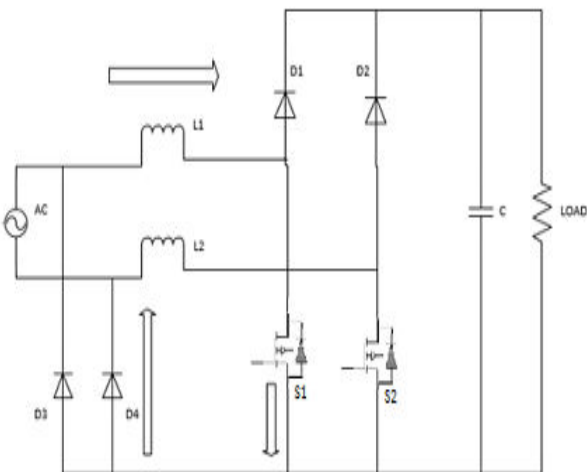

Fig.4. Mode I positive half cycle

Fig.5 shows the working principle of mode II in which switch S1 is in off state. As S1 is turned off so the current uses the path of diode D1 to pass through the load. In this mode the charged inductor L1 of mode I gets discharged by using the path of diode D1, load and diode D4.

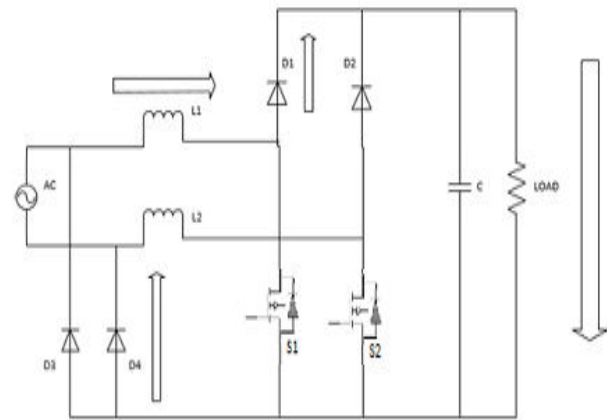

Fig.5. Mode II positive half cycle

### 2) Negative half cycle

For the duration of the negative half cycle of the ac line voltage, the current follows the path of second dc/dc boost converter; L2-D2-S2-D3. Diode D3 completes the circuit without including the inductor L1. This diode also connects the ground with the diode D3. Same like positive half cycle there are two modes of operation of negative half cycle (Mode III and Mode IV). Fig.6 shows the operation of mode III. The switch S2 is turned on to store the energy in inductor L2. The path followed during this operation mode, consists of  $V_{in}$ -L2-S2-D3.

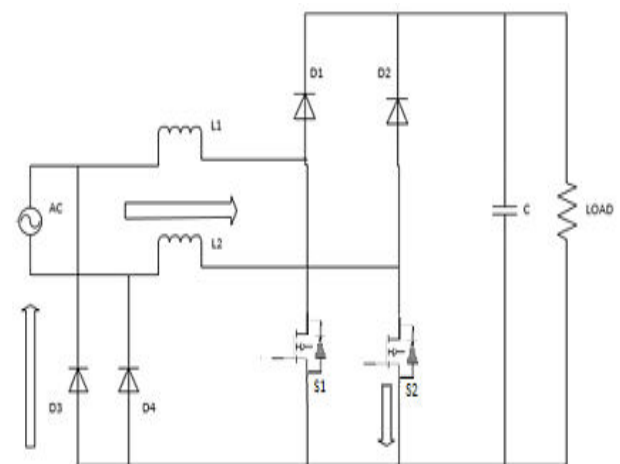

Fig.6. Mode III negative half cycle

Fig.7 shows the mode IV of operation in which switch S2 is turned off. As switch S2 is off so

the current uses the path of diode D2 to pass through the load. In this mode the charged inductor is discharged through the path of diode D2, load and diode D3.

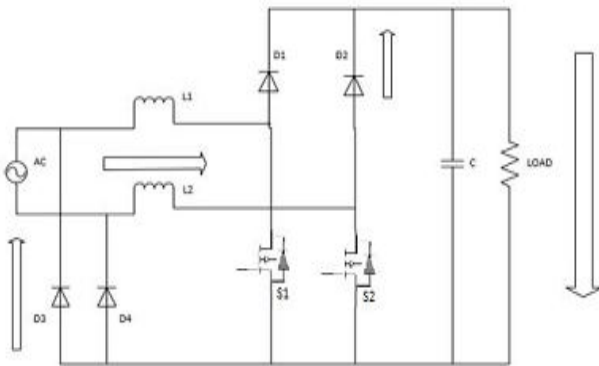

Fig.7. Mode IV positive half cycle  
**V. INDUCTION MOTOR**

An asynchronous motor type of an induction motor is an AC electric motor in which the electric current in the rotor needed to produce torque is obtained by electromagnetic induction from the magnetic field of the stator winding. An induction motor can therefore be made without electrical connections to the rotor as are found in universal, DC and synchronous motors. An asynchronous motor's rotor can be either wound type or squirrel-cage type. Three-phase squirrel-cage asynchronous motors are widely used in industrial drives because they are rugged, reliable and economical. Single-phase induction motors are used extensively for smaller loads, such as household appliances like fans. Although traditionally used in fixed-speed service, induction motors are increasingly being used with variable-frequency drives (VFDs) in variable-speed service. VFDs offer especially important energy savings opportunities for existing and prospective induction motors in variable-torque centrifugal fan, pump and compressor load applications. Squirrel cage induction motors are very widely used in both

fixed-speed and variable-frequency drive (VFD) applications. Variable voltage and variable frequency drives are also used in variable-speed service. In both induction and synchronous motors, the AC power supplied to the motor's stator creates a magnetic field that rotates in time with the AC oscillations. Whereas a synchronous motor's rotor turns at the same rate as the stator field, an induction motor's rotor rotates at a slower speed than the stator field. The induction motor stator's magnetic field is therefore changing or rotating relative to the rotor. This induces an opposing current in the induction motor's rotor, in effect the motor's secondary winding, when the latter is short-circuited or closed through external impedance. The rotating magnetic flux induces currents in the windings of the rotor; in a manner similar to currents induced in a transformer's secondary winding(s). The currents in the rotor windings in turn create magnetic fields in the rotor that react against the stator field. Due to Lenz's Law, the direction of the magnetic field created will be such as to oppose the change in current through the rotor windings. The cause of induced current in the rotor windings is the rotating stator magnetic field, so to oppose the change in rotor-winding currents the rotor will start to rotate in the direction of the rotating stator magnetic field. The rotor accelerates until the magnitude of induced rotor current and torque balances the applied load. Since rotation at synchronous speed would result in no induced rotor current, an induction motor always operates slower than synchronous speed. The difference, or "slip," between actual and synchronous speed varies from about 0.5 to 5.0% for standard Design B torque curve induction motors. The induction machine's essential character is that it is created

solely by induction instead of being separately excited as in synchronous or DC machines or being self-magnetized as in permanent magnet motors. For rotor currents to be induced the speed of the physical rotor must be lower than that of the stator's rotating magnetic field ( $n_s$ ); otherwise the magnetic field would not be moving relative to the rotor conductors and no currents would be induced. As the speed of the rotor drops below synchronous speed, the rotation rate of the magnetic field in the rotor increases, inducing more current in the windings and creating more torque. The ratio between the rotation rate of the magnetic field induced in the rotor and the rotation rate of the stator's rotating field is called slip. Under load, the speed drops and the slip increases enough to create sufficient torque to turn the load. For this reason, induction motors are sometimes referred to as asynchronous motors. An induction motor can be used as an induction generator, or it can be unrolled to form a linear induction motor which can directly generate linear motion.

### Synchronous Speed:

The rotational speed of the rotating magnetic field is called as synchronous speed.

$$N_s = \frac{120 \times f}{P} \quad (\text{RPM}) \quad (6)$$

Where,  $f$  = frequency of the supply

$P$  = number of poles

### Slip:

Rotor tries to catch up the synchronous speed of the stator field, and hence it rotates. But in practice, rotor never succeeds in catching up. If rotor catches up the stator speed, there won't be any relative speed between the stator flux and the rotor, hence no induced rotor current and no torque production to maintain the rotation. However, this won't stop the motor, the

rotor will slow down due to lost of torque, and the torque will again be exerted due to relative speed. That is why the rotor rotates at speed which is always less the synchronous speed. The difference between the synchronous speed ( $N_s$ ) and actual speed ( $N$ ) of the rotor is called as slip.

$$\% \text{ slip } s = \frac{N_s - N}{N_s} \times 100 \quad (7)$$

### VI. MATLAB/SIMULATION RESULTS

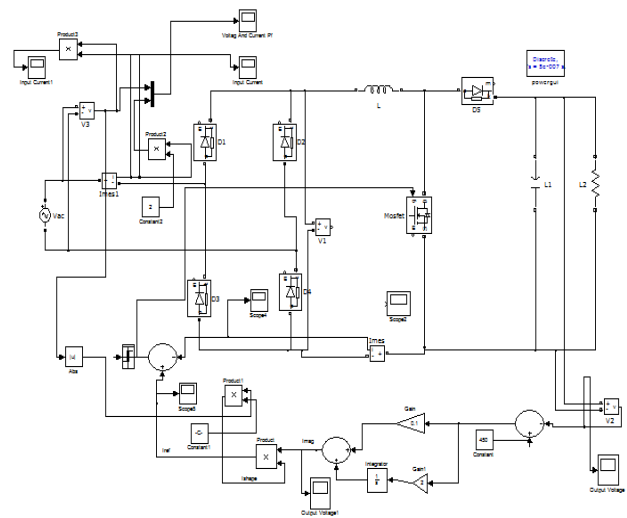

Fig.8 Matlab/Simulink model of bridge boost converter

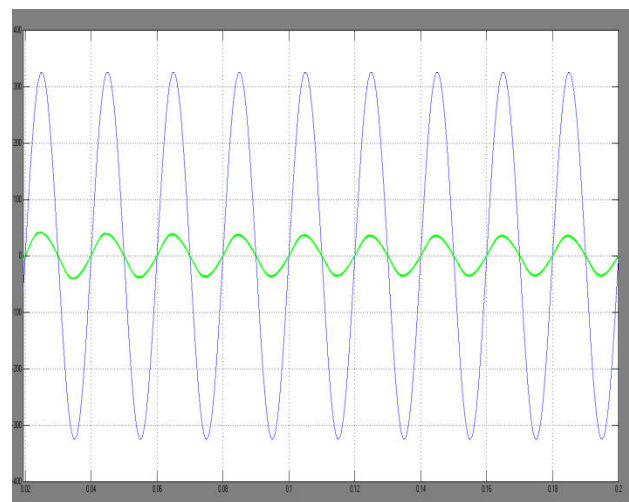

Fig.9. Current waveform and scaled voltage waveform of Bridge Boost Power Factor Correction Converter.



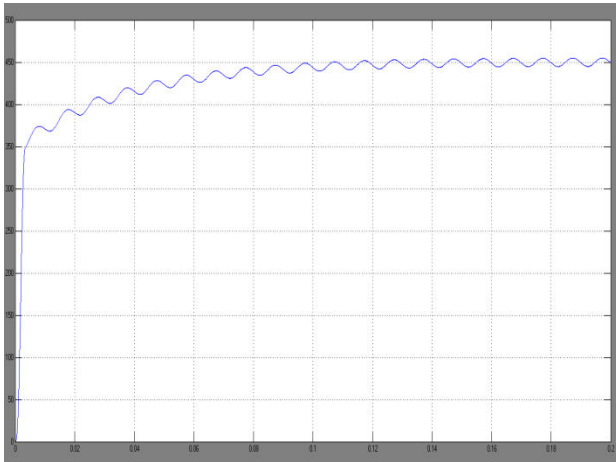

Fig.10 The output voltage regulation of Bridge Boost PFC Converter.

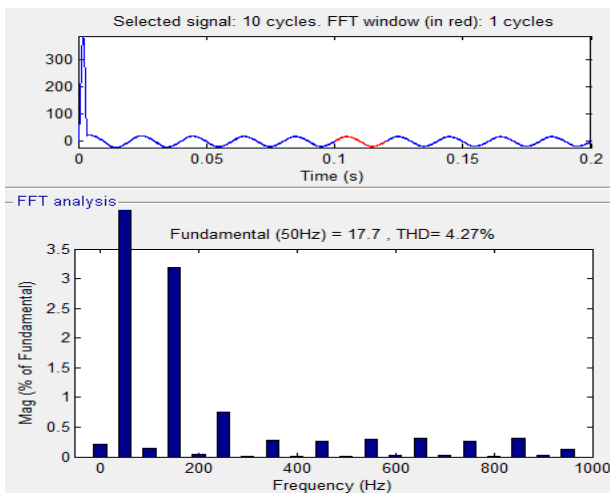

Fig.11. Frequency Response of input line current of Bridge Boost PFC Converter

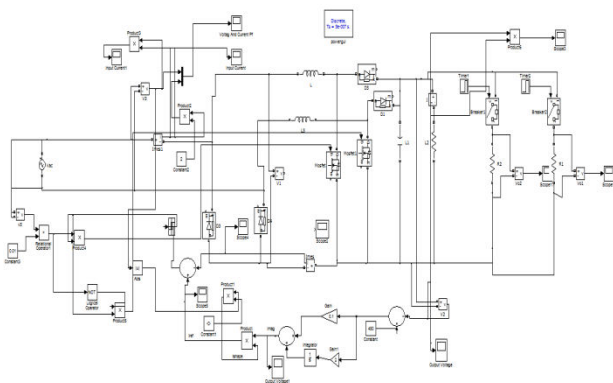

Fig.12 Matlab/Simulink model of bridgeless boost converter

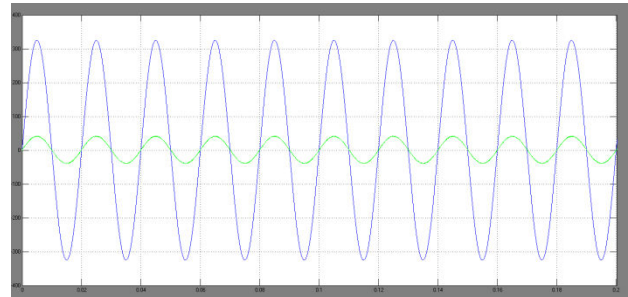

Fig.13. Current waveform and scaled voltage waveform of Bridgeless Boost Power Factor Correction Converter.

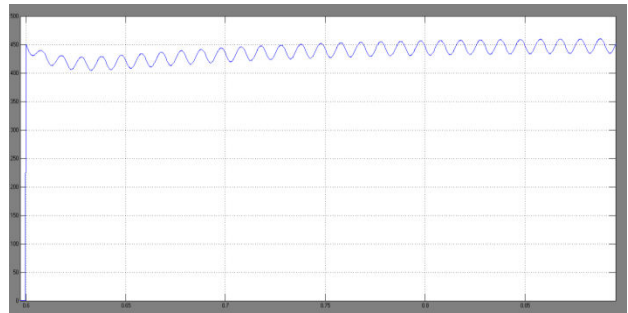

Fig.14. The output voltage regulation of Bridgeless Boost PFC Converter.

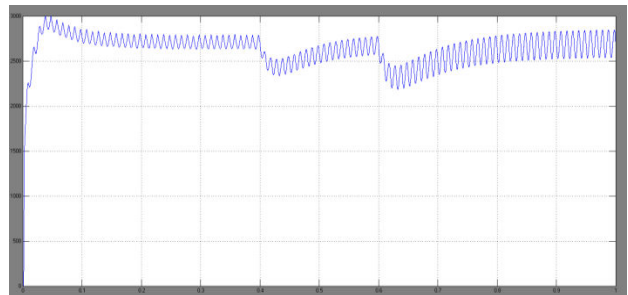

Fig.15. Output Power of the Bridgeless Boost PFC converter for switching loads of 1.28KW, 1.6KW & 2.13KW

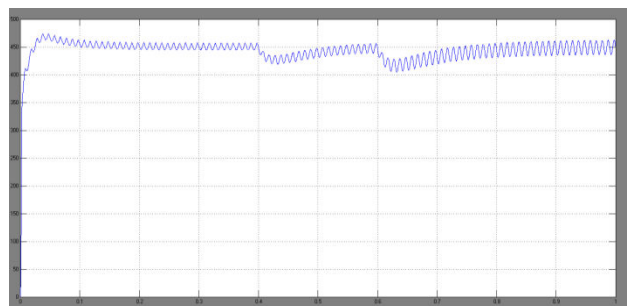

Fig.16. Output voltage regulation of the Bridgeless Boost PFC converter for switching loads of 1.28KW, 1.6KW & 2.13KW

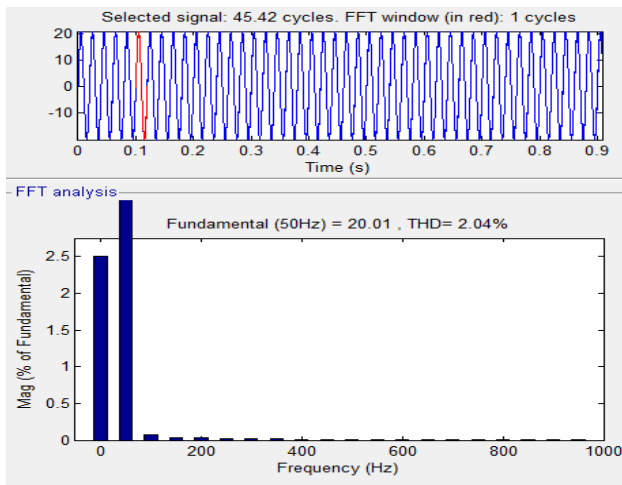

Fig.17. Frequency Response of input line current of Bridgeless Boost PFC Converter

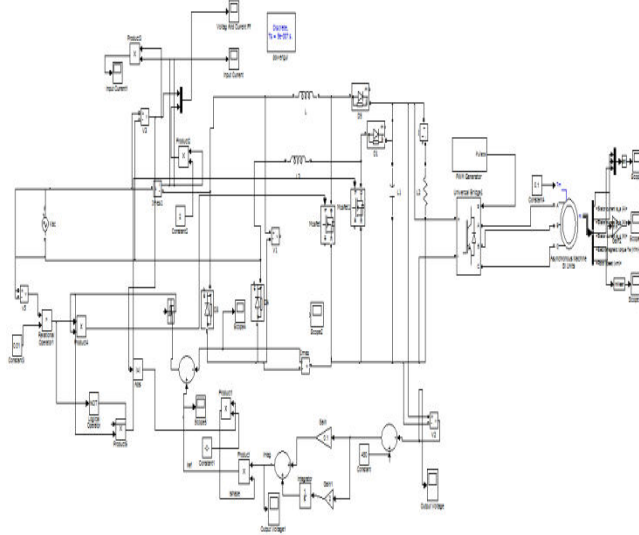

Fig.18 Matlab/Simulink model of bridgeless boost PFC converter with Induction motor

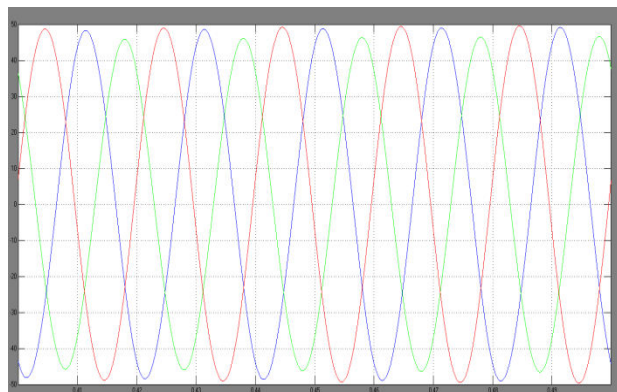

Fig.19 Induction motor stator current

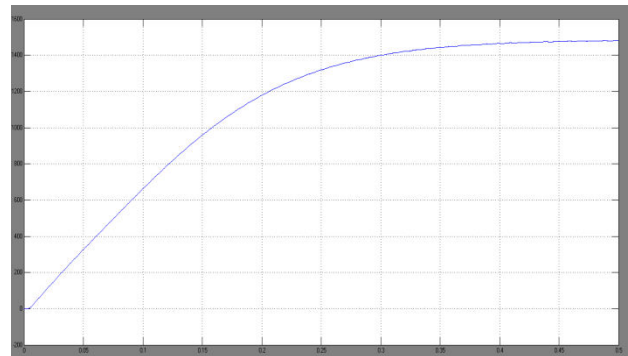

Fig.20 Speed of the induction motor

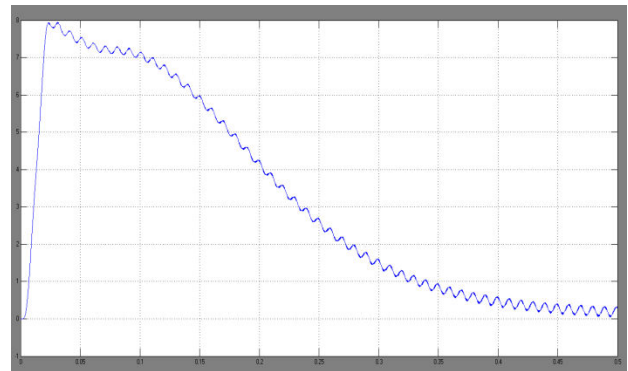

Fig.21 Torque characteristics of the induction motor

## VII. CONCLUSION

This paper deals with PFC Bridgeless boost converter has been presented. Higher power factor and reduced total harmonic distortion of the input current can be achieved. The bridgeless boost converter topology exhibits lower voltage stress over the whole input voltage range, and improved voltage gain and less conduction losses than the conventional bridge boost converter. The two power switches driven by the same control signal significantly simplifies the control circuitry. The conventional scheme has greater losses and ripple. Hence the bridgeless boost PFC converter can drive an induction motor drive efficiently. The closed loop operation of and the working of the converter fed induction motor drive has been validated using simulation and verified by experimental results.

## REFERENCES

- [1] G. V. Torrico-Bascopé and I. Barbi, "A single phase PFC 3kW converter using a three-state switching cell," in Proc. Power Electron. Spec. Conf., 2004, vol. 5, pp. 4037–4042
- [2] Darly, S. S.; Ranjan, P.V.; Bindu, K. V.; Rabi, B.J., "A novel dual boost rectifier for power factor improvement," 2011 1st International Conference on Electrical Energy Systems (ICEES), pp.122,127, 3-5 Jan. 2011
- [3] W.-Y. Choi, J.-M. Kwon, L. Jong-Jae, H.-Y. Jang, and B.-H. Kwon, "Single-stage soft-switching converter with boost type of active clamp for wide input voltage ranges," IEEE Transactions on Power Electronics, vol. 24, no. 3, pp. 730–741, 2009.
- [4] P. Das, M. Pahlevaninezhad, and G. Moschopoulos, "Analysis and design of a new ac-dc single-stage full-bridge pwm converter with two controllers," IEEE Transactions on Industrial Electronics, vol. 60, no. 11, pp. 4930–4946, 2013.
- [5] T. Nussbaumer, K. Raggl, and J. Kolar, "Design guidelines for interleaved single-phase boost pfc circuits," IEEE Transactions on Industrial Electronics, vol. 56, no. 7, pp. 2559–2573, 2009.
- [6] J. M. Kwon, W. Y. Choi, and B. H. Kwon, "Cost-effective boost converter with reverse-recovery reduction and power factor correction," IEEE Trans. Ind. Electron., vol. 55, no. 1, pp. 471–473, Jan. 2008.
- [7] Gopinath, M.; Prabakaran; Ramareddy, S., "A brief analysis on bridgeless boost PFC converter," Sustainable Energy and Intelligent Systems (SEISCON 2011), International Conference, pp.242,246, 20-22 July 2011
- [8] Huber, L.; Yungtaek Jang; Jovanovic, M.M., "Performance Evaluation of Bridgeless PFC Boost Rectifiers," Applied Power Electronics Conference, APEC 2007 - Twenty Second Annual IEEE, pp.165,171, Feb. 25 2007-March 1 2007
- [9] Mahdavi, M.; Farzanehfard, H., "New Bridgeless PFC converter with reduced components," Electronic Devices, Systems and Applications (ICEDSA), 2011 International Conference, pp.125,130, 25-27 April 2011
- [10] W. Wei, L. Hongpeng, J. Shigong, and X. Dianguo, "A novel bridgeless buck-boost PFC converter," in Proc. IEEE Power Electron. Spec. Conf., 2008, pp. 1304–1308.
- [11] Musavi, F.; Eberle, W.; Dunford, W.G., "A phase shifted semibridgeless boost power factor corrected converter for plug in hybrid electric vehicle battery chargers," Applied Power Electronics Conference and Exposition (APEC), 2011 Twenty-Sixth Annual IEEE, pp.821,828, 6-11 March 2011
- [12] R. Martinez and P. N. Enjeti, "A high-performance single-phase rectifier with input power factor correction," IEEE Trans. Power Electron., vol. 11, no. 2, pp. 311–317, Mar. 1996.
- [13] J. W. Lim and B. H. Kwon, "A power factor controller for single-phase PWM rectifiers," IEEE Trans. Ind. Electron., vol. 46, no. 5, pp. 1035–1037, Oct. 1999.