

COPY RIGHT



ELSEVIER
SSRN

2021IJIEMR. Personal use of this material is permitted. Permission from IJIEMR must be obtained for all other uses, in any current or future media, including reprinting/republishing this material for advertising or promotional purposes, creating new collective works, for resale or redistribution to servers or lists, or reuse of any copyrighted component of this work in other works. No Reprint should be done to this paper, all copy right is authenticated to Paper Authors

IJIEMR Transactions, online available on 20th Sep 2016.

Link : <https://ijiemr.org/downloads/Volume-05/Issue-07>

Title: APPLICATION OF FUZZY LOGIC TO SHUNT CONTROLLERS FOR IMPROVING POWER QUALITY IN GRID INTERFACED SYSTEM

volume 05, Issue 07, Pages: 31-37
Paper Authors : ¹Ms.K.Radhika, ²Ms.Ch.Jyothi



USE THIS BARCODE TO ACCESS YOUR ONLINE PAPER

APPLICATION OF FUZZY LOGIC TO SHUNT CONTROLLERS FOR IMPROVING POWER QUALITY IN GRID INTERFACED SYSTEM

¹Ms.K.Radhika, ²Ms.Ch.Jyothi,

^{1,2} Assistant Professor, Dept. of CSE,

Malla Reddy Engineering College (Autonomous), Secunderabad, Telangana State

Abstract: Generally, the non-conventional energy sources are being extensively used in case of power electronic converter based distribution systems. This paper mainly focuses on the wind energy system integrating with grid connected system and also improvement of power quality features. The wind energy power plant is modelled based on associated equations. For improving this power quality problems, this paper proposes the concepts of shunt converter controllers. This paper also proposes the concepts of fuzzy based Thyristor Switched Capacitor and Static Compensator and STATCOM. And also the results are compared for this cases. Thus with such a control, a balanced load currents are obtained even in the presence of non-linear load. The experimental setup is done in Matlab and verified the simulation results.

Index Terms—STATCOM, distributed generated system (DG), distribution system, and renewable energy, Fuzzy Logic.

1 .INTRODUCTION

Generally, with increase in the power demand due to increase in population, utilization, the Generation of power was really a challenge now a day. Due to high utilization of non-conventional energy sources [1] as a one of the distribution energy source, may causes the stability problems such as voltage regulation and other power quality problems. Therefore, the power electronic based forced commutated converters are preferred in distribution system for maintaining the system stability, reliable performance and efficient work and also improving the quality of power at coupling junction point.

The current distortions in non-linear load may result same distortions in the system voltages and in some cases also shows the serious effect on power system. Generally, the problems in power system are more complicated and also have difficult to identify the problem when we integrate the wind energy system with grid connection [2]. If this problems continuous, it's mainly causes the damage

of system and also reduces the system efficiency. By controlling the system parameters such as magnitude of voltage, transmission impedance and load angle then we maintain the power flow. The power flow controlling device is a device which is used for varying and controlling the system parameters [3].

A shunt device is a compensating device i.e. which is connected between the grid connected point called as PCC and the ground [4]. Shunt device either can absorb or generate the reactive power for controlling the magnitude of voltage at point of common coupling.

The reactive power compensation is also one of the application of shunt converter devices [5]. Figure 1 shows the basic diagram for the shunt connected inverter based grid connected system [6].

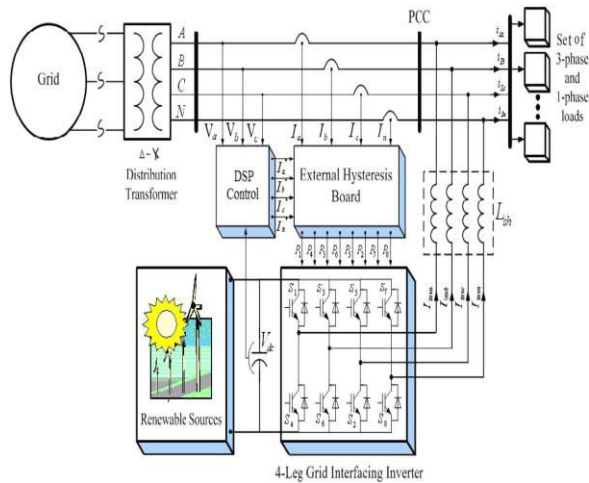

Fig 1: Diagram for Proposed System.

2. Grid Interconnection of Wind Energy System

Recently grid connected wind system have been spreading in residential areas and in industrial areas. So we have to find a suitable MPPT technique that gives a better power output when connected is to find out. For a grid connected system there are certain factors that have been considered such that DC-AC conversion with highest output power quality with the proper design of filters System main controlling factors like MPPT. Grid interface inverters which transfers the energy from the wind energy generation system to the grid by maintaining constant of dc link voltage. For a grid connected system the utility network mainly demands for better power quality and power output. In the case of voltage fluctuations control of grid parameters is very difficult. So for a wind system that is connected to a grid first stage is the boosting stage and the second stage is DC-AC converter [7]. An output filter is usually employed which reduces the ripple components due to switching problems. The problem associated with the grid connected system is that the dc link voltage that must be oscillates between the two levels which depends on the operating climatic conditions (ambient temperature & irradiance) in

which inverter which acts as a power controller between the dc link and the utility. Dc link is generally used to isolate between the grid side and the inverter side so that we can control both wind system and grid separately. All the available power that can be extracted from the wind system is transferred through the grid [8]-[9].

2.1 Wind Energy System:

The generation of electrical power is obtained mainly in two ways i.e one is conventional source and other is non-conventional energy sources. The generation of electricity using non-renewable resources such as coal, natural gas, oil and so on, shows great impact on the environment by production of pollution from their general gases. Hence, by considering all these conditions the generation of electricity is obtained from the renewable energy sources.

Basically, out of all renewable energy sources the wind turbine plays an important role for generating electricity. And also from economical point of view the wind turbine has low maintenance cost because it needs no fuel so that it is pollution free. Mostly, in present world 50-60 percent [13] of energy is generated from wind turbine as compared with all other renewable energy sources.

The typical layout of wind power generation as shown below.

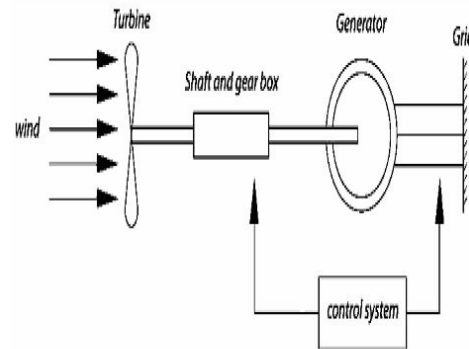

Fig.2 basic schematic diagram of wind turbine

The wind turbine converts wind energy to electrical energy and the generator mechanical shaft power is obtained by the following expression:

$$P_m = 0.5\rho AC_p v^3$$

And the coefficient of power also plays a key role for wind system and the basic minimum value of power coefficient is 0.5. The power coefficient is obtained by the ratio of tip speed ratio to pitch angle. The pitch angle is the angle to which the blades of turbine is arranged based on their longitude axis and changing of wind direction. The tip speed ratio is defined as ratio of linear speed of the rotor to the wind speed.

Fig.3 shows a typical waveform for coefficient of power with respect to the tip speed ratio. The maximum achievable range of TSR is from 0.4 to 0.5 for turbine with high speed and from 0.2 to 0.4 for turbine with low speed [14].

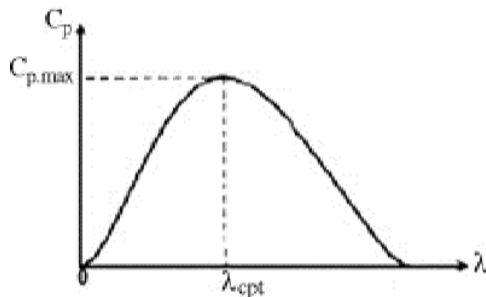

Fig 3: Power coefficient Vs Tip Speed Ratio

2.2 STATCOM and its Control Technique:

A STATCOM is a one of the compensated device which is obtained from the FACTS family [14] and is a combination of power electronic converter along with reactor. Mostly, the converter is constructed by the use of fully controlled devices such as GTO, IGBT or MOSFET. The main purpose of this STATCOM converter control technique is used to compensate the deviations in power system for improving power quality. In this paper grid interfaced wind turbine based STATCOM control scheme is proposed for improving the reliability of electrical power.

- Unity power factor at the source side.
- The Dc voltage is obtained for STATCOM is generated from Solar Cells.

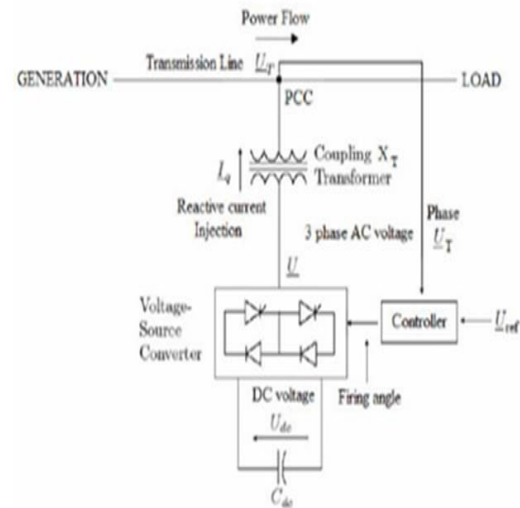

Fig 4: basic block diagram for static compensator.

Based on the utilization of electrical load in three phase system, it produces an unbalances in current, which causes the unreliable in power, finally it reduces the efficiency. Thereby for maintaining the electrical reliability the statcom controller plays a key role. In this statcom control technique, the reference voltage and dc link capacitor voltages are compared and the result obtained from this is converter to two phase coordinators called as orthogonal vectors.

THYRISTOR SWITCHED CAPACITOR:

The major and most important component of the family of static var compensator [15] is Thyristor Switched Capacitor. It is an equipment which is used for reactive power compensation in power systems. It is a combination of capacitor bank which is connected in series with the anti-parallel thyristor valve and a small current limiting inductor [16]. The thyristor switched capacitor is commonly a three phase system which is connected in either star or delta. As compared with thyristor controlled reactor the thyristor switched capacitor produces less harmonics thereby no need for extra filter circuits. Due to this reason the thyristor switched capacitor is mostly used in static var compensator family and used for only reactive power this can lead to less

economic [16]. The basic schematic diagram for thyristor switched capacitor is as shown in figure 4.

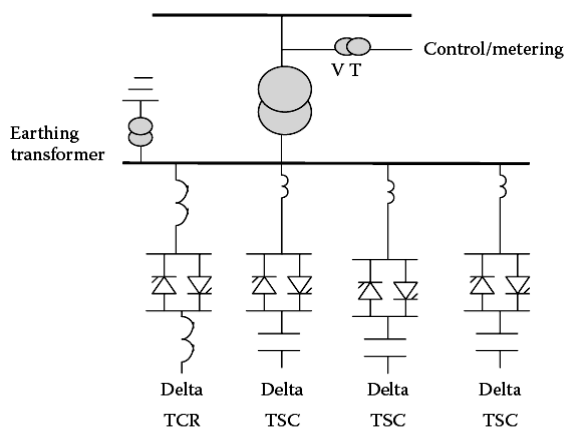

Fig 5: Thyristor Switched Capacitor

FUZZY LOGIC CONTROLLER

Fuzzy control system is a mathematical system which is completely based on fuzzy logic. Fuzzy controllers which are directly use the fuzzy rules. Fuzzy rules are conditional statements, gives the relationship among all fuzzy variables. The logic involved in the fuzzy controller [17] can deal with concepts that cannot be expressed as true or false. In below figure Fuzzy Logic Controller block diagram is shown.

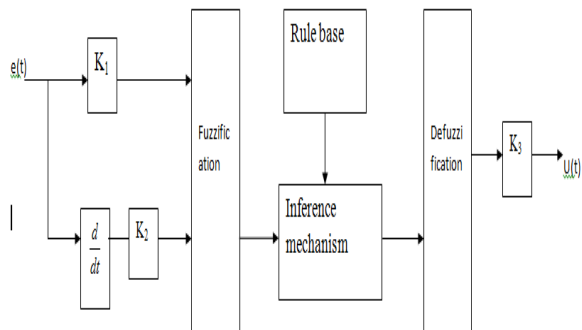

Fig.6 Fuzzy Logic Controller block diagram

The fuzzy set is defined by a function that maps objects in a domain of concern to their membership value in the set. Such a function is called membership function and is usually denoted by Greek symbol “ μ ”. Figure 6, shows the selection of number of inputs and outputs in the form of membership functions in order to design FIS [18].

3. SIMULATION STUDY

Case 1: Simulation result with use of TSC Converter

The simulation is done based on the fig 1, and it shows in figure 6 and the obtained power quality is shown below simulation waveforms.

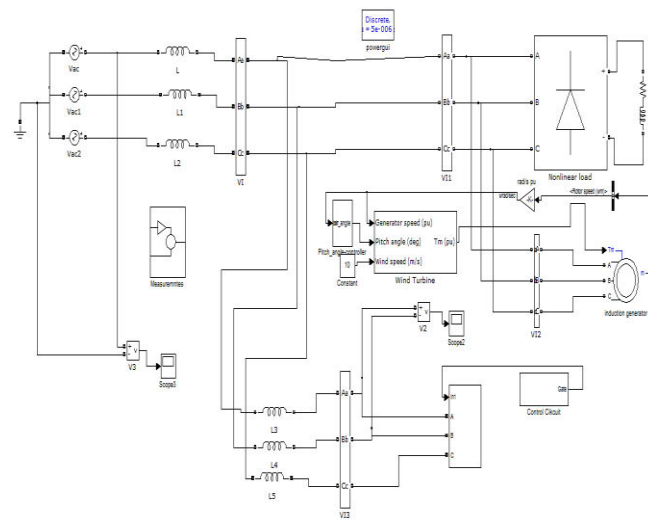

Fig 6: Simulation Diagram with TSC

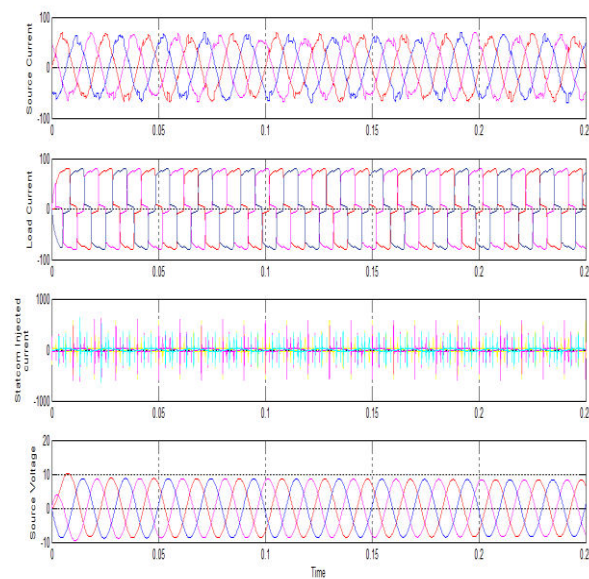

Fig 7: Results for Wind Energy System with TSC

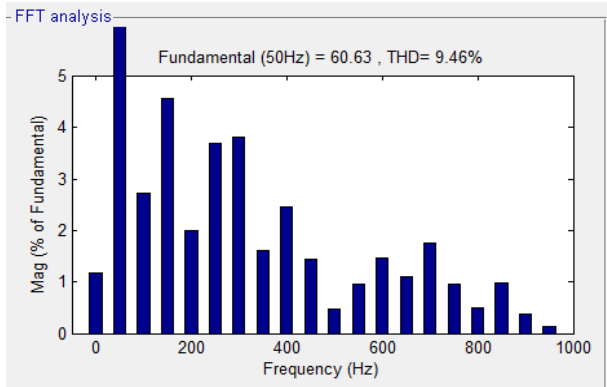

Fig 8: FFT analysis for Source current.

Case 2: Simulation Diagram and results with Statcom

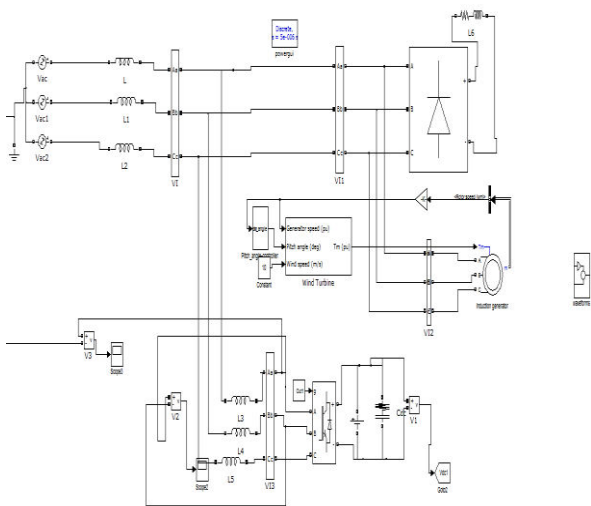

Fig 9: Over All Circuit Diagram in Simulation with Sub Systems

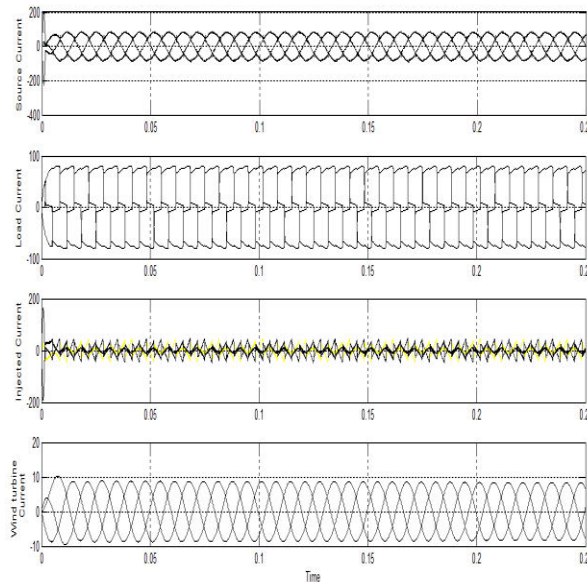

Fig 10: simulation result for current.

Fig 10 shows the result for source current, load current, injected current and current from the wind system.

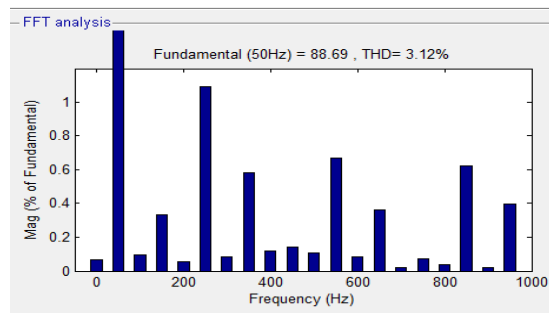

Fig 11: FFT analysis for Source current.

Case 3: Simulation Diagram and results with Fuzzy based Statcom

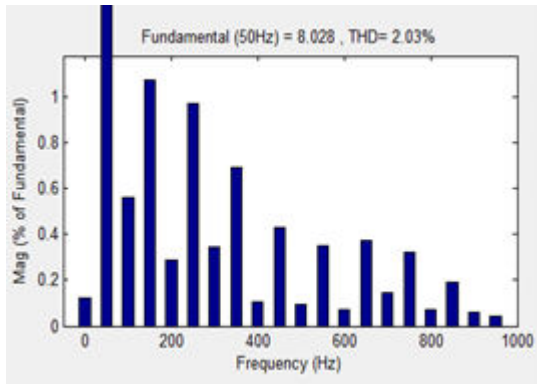

Fig 12: FFT analysis for Source current.

CONCLUSION

Finally, this paper proposes a novel concept of grid interfaced wind energy system with comparison of TSC and STATCOM controller for improving power quality. This paper also shows the concept of power quality problems and their problem effect on the consumer and electric utility systems are presented. Therefore, distortions in currents are eliminated and maintained voltage and current are in same phase for improving power factor so that and reactive power demand for the wind generator and load at PCC in the grid system. Hence, the integrated wind generation and FACTS device shown the outstanding performance in maintaining the PQ profile as per requirement. The operation of the STATCOM based grid connected wind energy system were practically developed and implemented in Matlab/Simulink and observed the simulation results. With this concepts the fuzzy-Statcom controller gets the better performance as compared with the TSC and Statcom controllers.

REFERENCE

[1] A. Q. Huang, M. Baran, S. Bhattacharya "STATCOM importance on the integration of a large

wind farm into a weak loop power system," IEEE Trans. Energy Conv., vol. 23, no. 1, pp. 226–232, Mar. 2008.

[2] Hook, Y. Liu, presents a paper on "Mitigation of the wind generation integration related power quality problems by energy storage," at EPQU J., vol. XII, no. 2, in 2006.

[2] A. Q. Huang, M. Baran, S. Bhattacharya "STATCOM importance on the integration of a large wind farm into a weak loop power system," IEEE Trans. Energy Conv., vol. 23, no. 1, pp. 226–232, Mar. 2008.

[4] Wind Turbine Generating System—Part 21, International standard-IEC 61400-21, 2001.

[5] J. Manel, "Power electronic system for grid integration of renewable energy source: A survey," IEEE Trans. Ind. Electron., vol. 53, no. 4, pp. 1002–1014, 2006, Carrasco.

[6] S. Papathanassiou, "paper on review of grid code technology requirements for wind turbine," Proc. IET Renew. Power gen., vol. 3, pp. 308–332, 2009.

[7] S. Heier, Grid Integration of Wind Energy Conversions. Hoboken, NJ: Wiley, 2007, pp. 256–259.

[8] J. J. Gutierrez, J. Ruiz, L. Leturiondo, and A. Lazkano, "Flicker measurement system for wind turbine certification," IEEE Trans. Instrum. Meas., vol. 58, no. 2, pp. 375–382, Feb. 2009.

[9] Indian Wind Grid Code Draft report on, Jul. 2009, pp. 15–18, C-NET.

[10] Hamad, A.E., 1986. "Analysis of Power System Stability Enhancement by Static VAR Compensators", IEEE Transactions on Power Systems, 1(4): 222-227.

[11] Hingorani, N.G. and L. Gyugyi, 1999. "Understanding FACTS", IEEE Press, New York.

[12] Hosseini, S.H and O. Mirshekhar, 2001. "Optimal Control of SVC for Subsynchronous Resonance Stability in Typical Power System", Proc. ISIE, 2: 916-921.

[13] Machowski, J., 1997. "Power System Dynamics and Stability", John Wiley and Sons.

[14] Oliveria, S.E.M., 1994. "Synchronizing and damping torque coefficients and power system steady state stability as affected by static var compensators", IEEE Transactions on Power Systems, 9(1): 109-116.



[15] Uzunovic, E., 2001. "EMTP, transient stability and power flow models and controls of VSC based facts controllers", PhD Thesis, Waterloo University, Ontario, Canada.

[16] Wang, H and F. Li, 2000. "Multivariable Sampled Regulators for the Coordinated Control of STATCOM AC and DC Voltage", IEE Proc- Gener. Transm. Distrib, 147(2): 93-98.

[17] Alok Agarwal ,Rajul Misra and Vipul Agarwal,"Fuzzy Logic based power oscillation damping through Unified power flow controller in Power System",MIT IJEIE , Vol.1, No.1,pp.11-15,Jan 2011

[18] Comparison between Conventional PID and Fuzzy Logic Controller for Liquid Flow Control: Performance Evaluation of Fuzzy Logic and PID Controller by Using MATLAB/Simulink by Gaurav, Amrit Kaur, International Journal of Innovative Technology and Exploring Engineering (IJITEE) ISSN: 2278-3075, Volume-1, Issue-1, June 2012