

ELSEVIER  
SSRN

## COPY RIGHT

**2020 IJIEMR.** Personal use of this material is permitted. Permission from IJIEMR must be obtained for all other uses, in any current or future media, including reprinting/republishing this material for advertising or promotional purposes, creating new collective works, for resale or redistribution to servers or lists, or reuse of any copyrighted component of this work in other works. No Reprint should be done to this paper, all copy right is authenticated to Paper Authors

IJIEMR Transactions, online available on 18 Oct 2020.

Link :

[https://papers.ssrn.com/sol3/JELJOUR\\_Results.cfm?form\\_name=journalbrowse&journal\\_id=3206923&dgcid=EngRN-PIP-IJIEMR\\_email\\_netann](https://papers.ssrn.com/sol3/JELJOUR_Results.cfm?form_name=journalbrowse&journal_id=3206923&dgcid=EngRN-PIP-IJIEMR_email_netann)

**Title:- MODELLING AND OPTIMIZATION OF ROLLER CONVEYOR SYSTEM USING DYNAMIC ANALYSIS.**

Volume 09, Issue 10, Pages: 43 - 59.

Paper Authors

**<sup>1</sup>SRIRAMA MANIDEEP KUMAR, <sup>2</sup>TR SYDANNA.**

Department of Mechanical Engineering Sreenivasa College of Engineering and Technology.



USE THIS BARCODE TO ACCESS YOUR ONLINE PAPER

## MODELLING AND OPTIMIZATION OF ROLLER CONVEYOR SYSTEM USING DYNAMIC ANALYSIS

<sup>1</sup>SRIRAMA MANIDEEP KUMAR, <sup>2</sup>TR SYDANNA

<sup>1</sup> M.tech Student, Department of Mechanical Engineering Sreenivasa College of Engineering and Technology, (AP).

<sup>2</sup>Assistant Professor, Department of Mechanical Engineering, Sreenivasa College of Engineering and Technology, (AP).

<sup>1</sup>[122N1A03A7@gmail.com](mailto:122N1A03A7@gmail.com), <sup>2</sup>[sectknl@gmail.com](mailto:sectknl@gmail.com)

### Abstract

Now-a-days the industry demands Cost/Weight effective devices to perform the operation effectively without sacrificing the longevity of the devices. Transport framework is bit of mechanical hardware used to transfer the material from one place to another. These are used in transport the material which are having heavy weight and bulky material. Conveyor system allows the quick and efficient transport for a variety of material and having a very popular material in handling and packing industries. There are many types of conveyor system are used in present and used according to needs used in various industries. Conveyors are safely to transport the material from one level to another level and they can reduce the human labour and it is less expensive.

In this project, mainly focused on developing light weight roller conveyor system using dynamic analysis. 3D modeling of roller conveyor system is done through Unigraphics CAD software and Structural dynamic analysis of conveyor system is done using Ansys software. Dynamic analysis is done using different materials and this analysis is used to determine the stress and free vibration characteristics of roller conveyor system. From analysis results best material for conveyor system is proposed which has less vibration characters.

### Keywords:

### INTRODUCTION

#### 1.1 CONVEYOR SYSTEM

Different methods such as fork lifting, use of bucket elevators, conveyors systems, crane, etc. has been identified for lifting or transporting bulk materials or products from one place to another in the manufacturing industries depending on the speed of handling, height of transportation, nature, quantity, size and weight of materials to be transported. The objective of this research work is to provide design data base for the development of a reliable and efficient belt conveyor system that will reduce cost and enhance productivity while simultaneously reducing dangers to workers operating them. Conveyor system is a mechanical system used in

moving materials from one place to another and finds application in most processing and manufacturing industries.

It is easier, safer, faster, more efficient and cheaper to transport materials from one processing stage to another with the aid of material handling equipment devoid of manual handling. Handling of materials which is an important factor in manufacturing is an integral part of facilities design and the efficiency of material handling equipment add to the performance level of a firm. Conveyor systems are durable and reliable in materials transportation and warehousing. Based on different principles of operation, there are different conveyor systems namely gravity, belt, screw, bucket, vibrating, pneumatic/hydraulic,

chain, spiral, grain conveyor systems, etc. The choice however depends on the volume to be transported, speed of transportation, size and weight of materials to be transported, height or distance of transportation, nature of material, method of production employed. Material handling equipment ranges from those that are operated manually to semiautomatic systems.

Conveyors are used:

- When material is to be moved frequently between specific points
- To move materials over a fixed path
- When there is a sufficient flow volume to justify the fixed conveyor investment

Being the most versatile of power conveyor, belt conveyors are the most frequently used. They are least expensive power conveyors.

## 1.2 Types of belt conveyor

Mainly Two types of belt conveyors are play major role in transporting equipments from point to point.

### A. Slider bed

The belt slides over a continuous metal bed which is attached between the tops of conveyor channel frames. Slider belt conveyor is excellent for production work where small parts of varying sizes or shapes must be carried or assembled. The surface remains constantly flat.

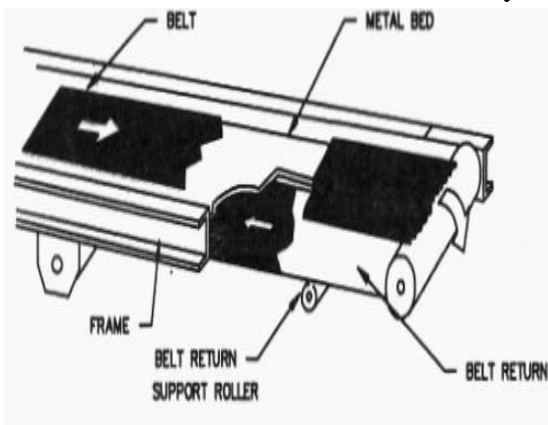

### B. Roller bed

The belt rolls over rollers rather than a metal bed. For light loads, one roller is sufficient under each load but for heavy loads, two or more rollers should be used.

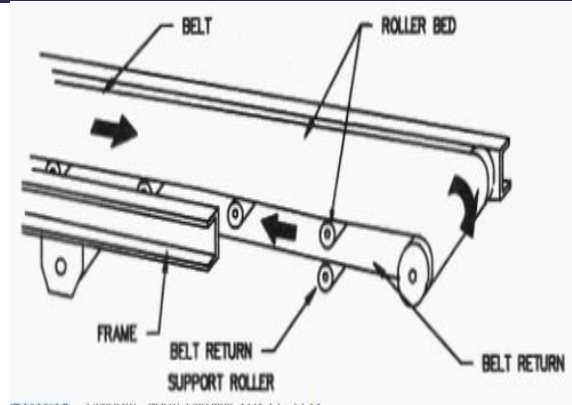

## UNIGRAPHICS INTRODUCTION

The NX Modelling application provides a solid modelling system to enable rapid conceptual design. Engineers can incorporate their requirements and design restrictions by defining mathematical relationships between different parts of the design.

Design engineers can quickly perform conceptual and detailed designs using the Modelling feature and constraint based solid modeller. They can create and edit complex, realistic, solid models interactively, and with far less effort than more traditional wire frame and solid based systems. Feature Based solid modelling and editing capabilities allow designers to change and update solid bodies by directly editing the dimensions of a solid feature and/or by using other geometric editing and construction techniques.

### Advantages of Solid Modelling

Solid Modelling raises the level of expression so that designs can be defined in terms of engineering features, rather than lower-level CAD geometry. Features are parametrically defined for dimension-driven editing based on size and position.

### Features

- Powerful built-in engineering-oriented form features-slots, holes, pads, bosses, pockets-capture design intent and increase productivity
- Patterns of feature instances-rectangular and circular arrays-with displacement of individual

features; all features in the pattern are associated with the master feature

### **Blending and Chamfering**

- zero radius
- Ability to chamfer any edge
- Cliff-edge blends for designs that cannot accommodate complete blend radius but still require blends

### **Advanced Modelling Operations**

- Profiles can be swept, extruded or revolved to form solids
- Extremely powerful hollow body command turns solids into thin-walled designs in seconds; inner wall topology will differ from the outer wall, if necessary
- Fixed and variable radius blends may overlap surrounding faces and extend to a Tapering for modelling manufactured near-net shape parts
- User-defined features for common design elements (NX/User-Defined Features is required to define them in advance)

### **General Operation**

Start with a Sketch Use the Sketcher to freehand a sketch, and dimension an "outline" of Curves. You can then sweep the sketch using pad Body or shaft Body to create a solid or sheet body. You can later refine the sketch to precisely represent the object of interest by editing the dimensions and by creating relationships between geometric objects. Editing a dimension of the sketch not only modifies the geometry of the sketch, but also the body created from the sketch.

### **Creating and Editing Features**

#### **Associativity**

Associativity is a term that is used to indicate geometric relationships between individual portions of a model. These relationships are established as the designer uses various functions for model creation. In an associative model, constraints and relationships are captured automatically as the model is developed. For example, in an associative

model, a through hole is associated with the faces that the hole penetrates. If the model is later changed so that one or both of those faces moves, the hole updates automatically due to its association with the faces. See Introduction to Feature Modeling for additional details.

#### **Positioning a Feature**

Within Modeling, you can position a feature relative to the geometry on your model using Positioning Methods, where you position dimensions. The feature is then associated with that geometry and will maintain those associations whenever you edit the model. You can also edit the position of the feature by changing the values of the positioning dimensions.

#### **Reference Features**

You can create reference features, such as Datum Planes, Datum Axes and Datum CSYS, which you can use as reference geometry when needed, or as construction devices for other features. Any feature created using a reference feature is associated to that reference feature and retains that association during edits to the model. You can use a datum plane as a reference plane in constructing sketches, creating features, and positioning features. You can use a datum axis to create datum planes, to place items concentrically, or to create radial patterns.

#### **Expressions**

The Expressions tool lets you incorporate your requirements and design restrictions by defining mathematical relationships between different parts of the design. For example, you can define the height of a boss as three times its diameter, so that when the diameter changes, the height changes also.

#### **Boolean Operations**

Modelling provides the following Boolean Operations: Unite, Subtract, and Intersect. Unite combines bodies, for example, uniting two rectangular blocks to form a T-shaped solid body. Subtract removes one body

from another, for example, removing a cylinder from a block to form a hole. Intersect creates a solid body from material shared by two solid bodies. These operations can also be used with free form features called sheets.

## **Undo**

You can return a design to a previous state any number of times using the Undo function. You do not have to take a great deal of time making sure each operation is absolutely correct, because a mistake can be easily undone. This freedom to easily change the model lets you cease worrying about getting it wrong, and frees you to explore more possibilities to get it right.

## **Additional Capabilities**

Other NX applications can operate directly on solid objects created within Modeling without any translation of the solid body. For example, you can perform drafting, engineering analysis, and machining functions by accessing the appropriate application. Using Modeling, you can design a complete, unambiguous, three dimensional model to describe an object. You can extract a wide range of physical properties from the solid bodies, including mass properties. Shading and hidden line capabilities help you visualize complex assemblies. You can identify interferences automatically, eliminating the need to attempt to do so manually. Hidden edge views can later be generated and placed on drawings. Fully associative dimensioned drawings can be created from solid models using the appropriate options of the Drafting application. If the solid model is edited later, the drawing and dimensions are updated automatically.

## **Parent/Child Relationships**

If a feature depends on another object for its existence, it is a child or dependent of that object. The object, in turn, is a parent of its child feature. For example, if a HOLLOW (1) is created in a BLOCK (0), the block is the parent

and the hollow is its child. A parent can have more than one child, and a child can have more than one parent. A feature that is a child can also be a parent of other features. To see all of the parent-child relationships between the features in your work part, open the Part Navigator.

## **Creating a Solid Model**

Modelling provides the design engineer with intuitive and comfortable modeling techniques such as sketching, feature based modeling, and dimension driven editing. An excellent way to begin a design concept is with a sketch. When you use a sketch, a rough idea of the part becomes represented and constrained, based on the fit and function requirements of your design. In this way, your design intent is captured. This ensures that when the design is passed down to the next level of engineering, the basic requirements are not lost when the design is edited.

The strategy you use to create and edit your model to form the desired object depends on the form and complexity of the object. You will likely use several different methods during a work session. The next several figures illustrate one example of the design process, starting with a sketch and ending with a finished model. First, you can create a sketch "outline" of curves. Then you can sweep or rotate these curves to create a complex portion of your design.

## **Introduction to Drafting**

The Drafting application is designed to allow you to create and maintain a variety of drawings made from models generated from within the Modeling application. Drawings created in the Drafting application are fully associative to the model. Any changes made to the model are automatically reflected in the drawing. This associativity allows you to make as many model changes as you wish. Besides the powerful associativity functionality, Drafting contains many other useful features including the following:

- An intuitive, easy to use, graphical user interface. This allows you to create drawings quickly and easily.
- A drawing board paradigm in which you work "on a drawing." This approach is similar to the way a drafter would work on a drawing board. This method greatly increases productivity.
- Support of new assembly architecture and concurrent engineering. This allows the drafter to make drawings at the same time as the designer works on the model.
- The capability to create fully associative cross-sectional views with automatic hidden line rendering and crosshatching.
- Automatic orthographic view alignment. This allows you to quickly place views on a drawing, without having to consider their alignment.
- Automatic hidden line rendering of drawing views.
- The ability to edit most drafting objects (e.g., dimensions, symbols, etc.) from the graphics window. This allows you to create drafting objects and make changes to them immediately.
- On-screen feedback during the drafting process to reduce rework and editing.
- User controls for drawing updates, which enhance user productivity.

Finally, you can add form features, such as chamfers, holes, slots, or even user defined features to complete the object.

- The Playback option on the Edit Feature dialog, which recreates the model, starting at its first feature. You can step through the model as it is created one feature at a time, move forward or backward to any feature, or trigger an update that continues until a failure occurs or the model is complete.

The Edit during Update dialog, which appears when you choose Playback, also includes options for analyzing and editing features of the model as it is recreated (especially useful for

fixing problems that caused update failures). Methods that users have tried in the past that has led to some problems or is tricky to use:

- One method uses the Edit Feature dialog to change the value of a parameter in each root feature of a part, and then change it back before leaving the Edit Feature dialog. This method produces a genuine net null update if used correctly, but you should ensure that you changed a parameter in every root feature (and that you returned all the parameters to their original values) before you trigger the update.
- Another method, attempting to suppress all of the features in a part and then unsuppressed them, can cause updates that are not net null and that will fail. The failures occur because not all features are suppressible; they are left in the model when you try to suppress all features. As the update advances, when it reaches the point where most features were suppressed, it will try to update the features that remain (this is like updating a modified version of the model). Some of the "modifications" may cause the remaining features to fail. For these reasons, we highly recommend that you do not attempt to update models by suppressing all or unsurprising all features. Use the other options described here, instead.

## **ASSEMBLIES CONCEPTS**

### **Components**

Assembly part files point to geometry and features in the subordinate parts rather than creating duplicate copies of those objects at each level in the assembly. This technique not only minimizes the size of assembly parts files, but also provides high levels of associativity. For example, modifying the geometry of one component causes all assemblies that use that component in the session to automatically reflect that change. Some properties, such as translucency and partial shading (on the Edit Object Display dialog), can be changed directly

on a selected component. Other properties are changed on selected solids or geometry within a component. Within an assembly, a particular part may be used in many places. Each usage is referred to as a component and the file containing the actual geometry for the component is called the component part.

- **Top-down or Bottom-up Modelling**

You are not limited to any one particular approach to building the assembly. You can create individual models in isolation, then later add them to assemblies (bottom-up), or you can create them directly at the assembly level (top-down). For example, you can initially work in a top-down fashion, then switch back and forth between bottom-up and top-down modelling.

- **Design in Context**

When the displayed part is an assembly, it is possible to change the work part to any of the components within that assembly (except for unloaded parts and parts of different units). Geometry features, and components can then be added to or edited within the work part. Geometry outside of the work part can be referenced in many modeling operations. For example, control points on geometry outside of the work part can be used to position a feature within the work part. When an object is designed in context, it is added to the reference set used to represent the work part.

- **Associativity Maintained**

Geometric changes made at any level within an assembly result in the update of associated data at all other levels of affected assemblies. An edit to an individual piece part causes all assembly drawings that use that part to be updated appropriately. Conversely, an edit made to a component in the context of an assembly results in the update of drawings and other associated objects (such as tool paths) within the component part. See the next two figures for examples of top-down and bottom-up updates.

- **Mating Conditions**

Mating conditions let you position components in an assembly. This mating is accomplished by specifying constraint relationships between two components in the assembly. For example, you can specify that a cylindrical face on one component is to be coaxial with a conical face on another component. You can use combinations of different constraints to completely specify a component's position in the assembly. The system considers one of the components as fixed in a constant location, then calculates a position for the other component which satisfies the specified constraints. The relationship between the two components is associative. If you move the fixed component's location, the component that is mated to it also moves when you update. For example, if you mate a bolt to a hole, if the hole is moved, the bolt moves with it.

- **Using Reference Sets to Reduce the Graphic Display**

Large, complex assemblies can be simplified graphically by filtering the amount of data that is used to represent a given component or subassembly by using reference sets. Reference sets can be used to drastically reduce (or even totally eliminate) the graphical representation of portions of the assembly without modifying the actual assembly structure or underlying geometric models. Each component can use a different reference set, thus allowing different representations of the same part within a single assembly. The figure below shows an example of a bushing component used twice in an assembly, each displayed with a different reference set.

When you open an assembly, it is automatically updated to reflect the latest versions of all components it uses. Load Options lets you control the extent to which changes made by other users affect your assemblies. Drawings of assemblies are created in much the same way as piece part drawings. You can

attach dimensions, ID symbols and other drafting objects to component geometry. A parts list is a table summarizing the quantities and attributes of components used in the current assembly. You can add a parts list to the assembly drawing along with associated callout symbols, all of which are updated as the assembly structure is modified. See the following figure.

## DESIGNING OF ROLLER CONVEYOR PROCEDURE

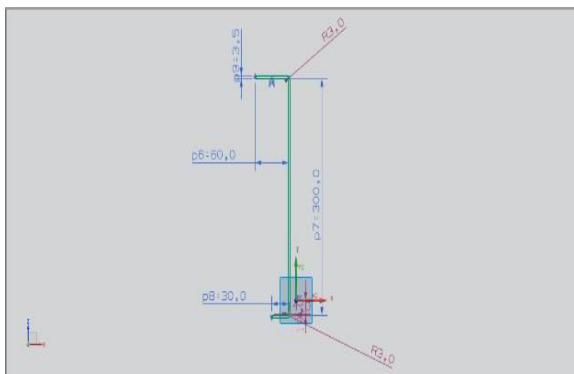

Fig.3.1 2D Sketch of Conveyor

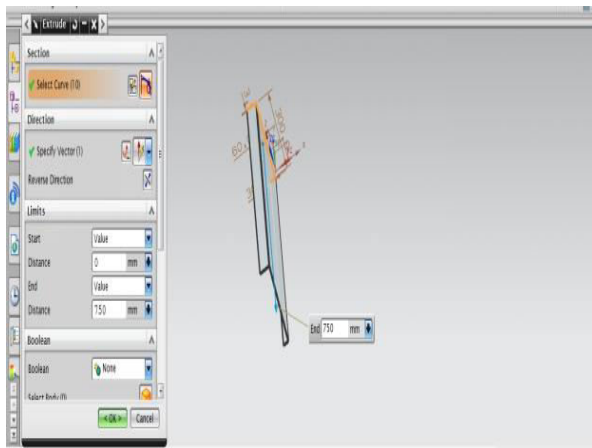

Fig.3.2 Extrude of Conveyor

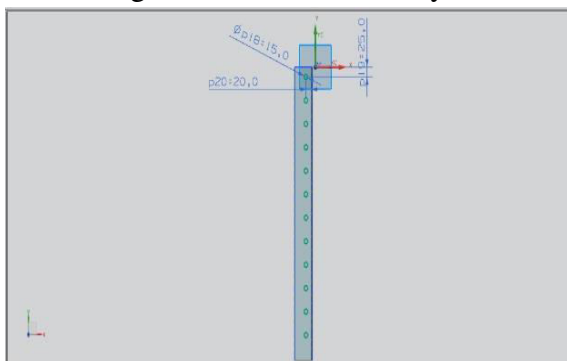

Fig.3.3 2D Sketch of Conveyor

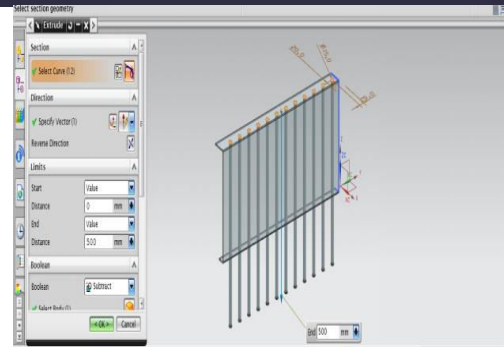

Fig.3.4 Extrude of Conveyor

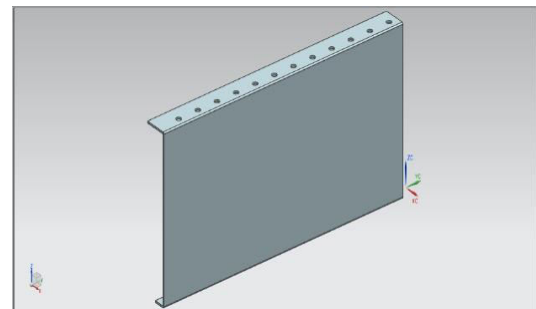

Fig.3.5 Flat bed of Conveyor

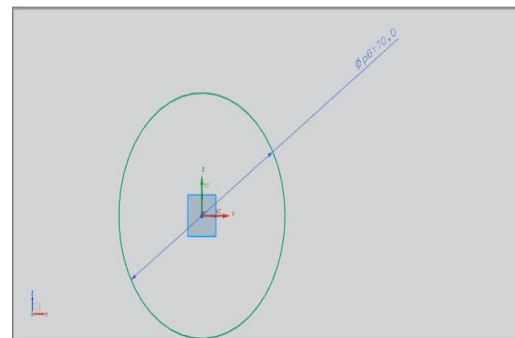

Fig.3.6 2D Sketch of roller

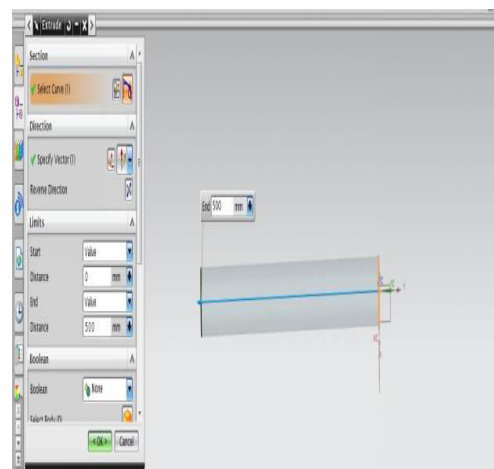

Fig.3.7 Extrude of roller



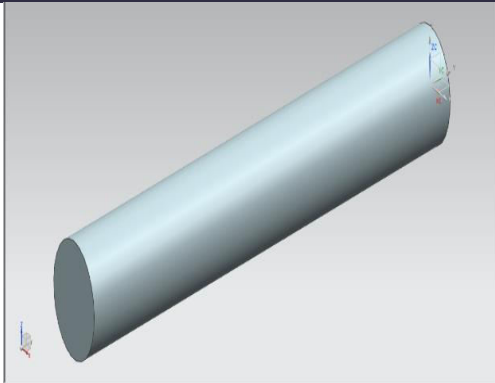

Fig.3.8 Solid Roller final design

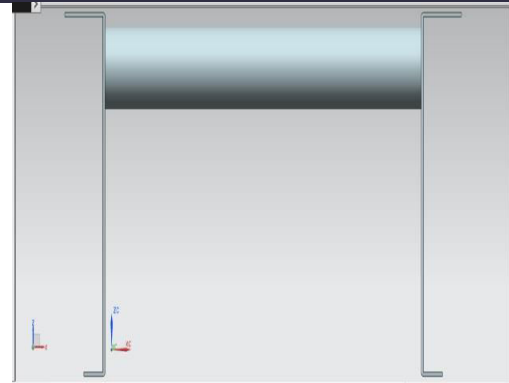

Fig.3.12 Roller final design

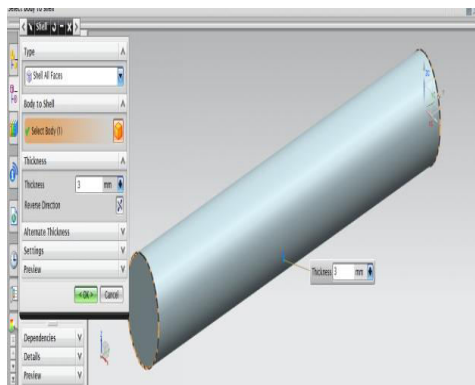

Fig.3.9 Making hollow Roller using shell

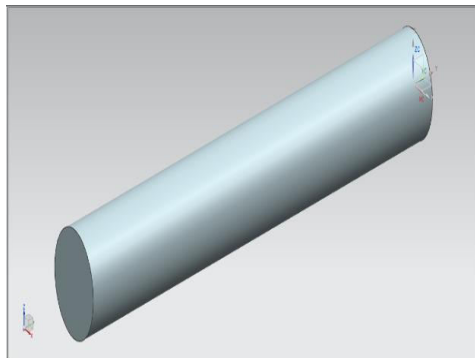

Fig.3.10 Roller final design

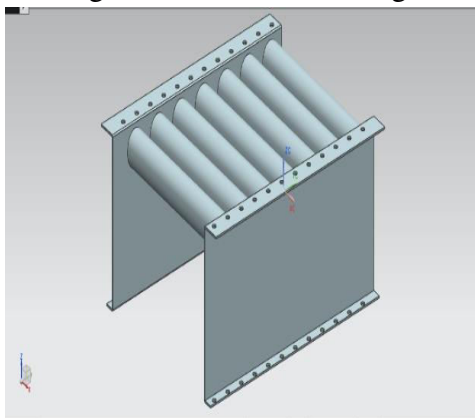

Fig.3.11 Roller conveyor final design

## STRUCTURAL ANALYSIS OF ROLLER CONVEYOR

### INTRODUCTION ABOUT FEM & ANSYS FINITE ELEMENT METHOD

The Basic concept in FEA is that the body or structure may be divided into smaller elements of finite dimensions called “Finite Elements”. The original body or the structure is then considered as an assemblage of these elements connected at a finite number of joints called “Nodes” or “Nodal Points”. Simple functions are chosen to approximate the displacements over each finite element. Such assumed functions are called “shape functions”. This will represent the displacement within the element in terms of the displacement at the nodes of the element.

The Finite Element Method is a mathematical tool for solving ordinary and partial differential equations. Because it is a numerical tool, it has the ability to solve the complex problems that can be represented in differential equations form. The applications of FEM are limitless as regards the solution of practical design problems.

Due to high cost of computing power of years gone by, FEA has a history of being used to solve complex and cost critical problems. Classical methods alone usually cannot provide adequate information to determine the safe working limits of a major civil engineering construction or an automobile or an aircraft. In the recent years, FEA has been universally used

to solve structural engineering problems. The departments, which are heavily relied on this technology, are the automotive and aerospace industry. Due to the need to meet the extreme demands for faster, stronger, efficient and lightweight automobiles and aircraft, manufacturers have to rely on this technique to stay competitive.

FEA has been used routinely in high volume production and manufacturing industries for many years, as to get a product design wrong would be detrimental. For example, if a large manufacturer had to recall one model alone due to a hand brake design fault, they would end up having to replace up to few millions of hand brakes. This will cause a heavier loss to the company.

The finite element method is a very important tool for those involved in engineering design; it is now used routinely to solve problems in the following areas.

- Structural analysis
- Thermal analysis
- Vibrations and Dynamics
- Buckling analysis
- Acoustics
- Fluid flow simulations
- Crash simulations
- **Mold flow simulations**

Nowadays, even the most simple of products rely on the finite element method for design evaluation. This is because contemporary design problems usually cannot be solved as accurately & cheaply using any other method that is currently available. Physical testing was the norm in the years gone by, but now it is simply too expensive and time consuming also.

**Basic Concepts:** The Finite Element Method is based on the idea of building a complicated object with simple blocks, or, dividing a complicated object into small and manageable pieces. Application of this simple idea can be found everywhere in everyday life as well as engineering. The philosophy of FEA can be

explained with a small example such as measuring the area of a circle. Area of one Triangle:  $S_i = \frac{1}{2} * R^2 * \sin \alpha_i$

Where N = total number of triangles (elements)

If one needs to evaluate the area of the circle without using the conventional formula, one of the approaches could be to divide the above area into a number of equal segments. the area of each triangle multiplied by the number of such segments gives the total area of the circle.

## **A BRIEF HISTORY OF THE FEM:**

### **WHO**

The reference credited is to Courant (Mathematician), Turner (air craft industry), Clough (California university), Martin (air craft industry), Argyris (German university),....., However, it was probably established by several pioneers independently.

### **WHEN**

- Initial idea in mathematical terms was put in 1940s.
- Application to simple engineering problems in 1950s.
- Implementation in large computer is 1960s.
- Development of pre and post processors in 1980s.
- Analysis of large structural problems in 1990s.

### **WHERE**

Implementation and application were mainly in aircraft industry and automobile sectors (large and fast computers were available only in these industries)

### **WHAT**

Field problems in the form matrix methods of organizing large numbers of algebraic equations are used and matrix equations are solved. Differential equations are transformed into an algebraic form. Blocks with different geometry are hooked together for creating complex geometry of the engineering problem

### **WHY**

The advantage of doing FEM analysis is that it is fairly simple to change the geometry, material

and loads recomputed stresses for modified product rather than build and test. The method can be used to solve almost any problem that can be formulated as a field problem. The entire complex problem can be cast as a larger algebraic equation by assembling the element matrices within the computer and solved.

### Available Commercial FEM software packages

- ANSYS (General purpose, PC and workstations)
- SDRC/I-DEAS (Complete CAD/CAM/CAE package)
- NASTRAN (General purpose FEA on mainframes)
- LS-DYNA 3D (Crash/impact simulations)
- ABAQUS (Nonlinear dynamic analysis)
- NISA (A General purpose FEA tool)
- PATRAN (Pre/Post processor)
- HYPERMESH (Pre/post processor)

### ANSYS INTRODUCTION

The ANSYS program is self contained general purpose finite element program developed and maintained by Swanson Analysis Systems Inc. The program contain many routines, all inter related, and all for main purpose of achieving a solution to an an engineering problem by finite element method.

ANSYS finite element analysis software enables engineers to perform the following tasks:

- Build computer models or transfer CAD models of structures, products, components, or systems.
- Apply operating loads or other design performance conditions
- Study physical responses, such as stress levels, temperature distributions, or electromagnetic fields
- Optimize a design early in the development process to reduce production costs.
- Do prototype testing in environments where it otherwise would be undesirable or impossible

The ANSYS program has a compressive graphical user interface (GUI) that gives users easy, interactive access to program functions, commands, documentation, and reference material. An intuitive menu system helps users navigate through the ANSYS Program. Users can input data using a mouse, a keyboard, or a combination of both. A graphical user interface is available throughout the program, to guide new users through the learning process and provide more experienced users with multiple windows, pull-down menus, dialog boxes, tool bar and online documentation.

### ORGANIZATION OF THE ANSYS PROGRAM

The ANSYS program is organized into two basic levels:

- Begin level
- Processor (or Routine) level

The begin level acts as a gateway in to and out of the ANSYS program. It is also used for certain global program controls such as changing the job name, clearing (zeroing out) the database, and copying binary files. When we first enter the program, we are at the begin level. At the processor level, several processors are available; each processor is a set of functions that perform a specific analysis task. For example, the general preprocessor (PREP7) is where we build the model, the solution processor(SOLUTION)is where we apply loads and obtain the solution, and the general postprocessor(POST1) is where we evaluate the results and obtain the solution. An additional postprocessor (POST26), enables we to evaluate solution results at specific points in the model as a function of time.

### PERFORMING A TYPICAL ANSYS ANALYSIS

The ANSYS program has many finite element analysis capabilities, ranging from a simple, linear, static analysis to a complex, nonlinear, transient dynamic analysis. The analysis guide manuals in the ANSYS documentation set

describe specific procedures for performing analysis for different engineering disciplines.

**A typical ANSYS analysis has three distinct steps:**

- Build the model
- Apply loads and obtain the solution
- Review the results

### **PRE PROCESSOR:**

The input data for an ANSYS analysis are prepared using a pre-processor. The general pre-processor (PREP 7) contains powerful solid modelling and mesh generation capabilities, and is also used to define all other analysis data with the benefit of data base definition and manipulation of analysis data. Parametric input, user files, macros and extensive online documentation are also available, providing more tools and flexibility

For the analyst to define the problem. Extensive graphics capability is available throughout the ANSYS program, including isometric, perspective, section, edge, and hidden-line displays of three-dimensional structures-y graphs of input quantities and results, and contour displays of solution results.

**The pre-processor stage involves the following:**

- Specify the title, which is the name of the problem. This is optional but very useful, especially if a number of design iterations are to be completed on the same base mode.
- Setting the type of analysis to be used ,e.g., Structural, Thermal, Fluid, or electromagnetic, etc
- Creating the model. The model may be created in pre-processor, or it can be imported from another CAD drafting package via a neutral file format.
- Defining element type, these chosen from element library.
- Assigning real constants and material properties like young's modulus, Poisson's ratio, density, thermal conductivity, damping effect, specific heat, etc

- Apply mesh. Mesh generation is the process of dividing the analysis continuum into number of discrete parts of finite elements.

### **SOLUTION PROCESSOR**

Here we create the environment to the model, i.e, applying constraints & loads. This is the main phase of the analysis, where the problem can be solved by using different solution techniques. Her three major steps involved:

- Solution type required, i.e. static, modal, or transient etc., is selected
- Defining loads. The loads may be point loads, surface loads; thermal loads like temperature, or fluid pressure, velocity are applied.
- Solve FE solver can be logically divided in o three main steps, the pre-solver, the mathematical-engine and post-solver. The pre-solver reads the model created by pre-processor and formulates the mathematical representation of the model and calls the mathematical-engine, which calculates the result. The result return to the solver and the post solver is used to calculate strains, stresses, etc., for each node within the component or continuum.

### **POST –PROCESSOR:**

Post processing means the results of an analysis. It is probably the most important step in the analysis, because we are trying to understand how the applied loads affects the design, how food your finite element mesh is, and so on.

The analysis results are reviewed using postprocessors, which have the ability to display distorted geometries, stress and strain contours, flow fields, safety factor contours, contours of potential field results; vector field displays mode shapes and time history graphs. The postprocessor can also be used for algebraic operations, database manipulators, differentiation, and integration of calculated results. Response spectra may be generated from dynamic analysis. Results from various loading

may be harmonically loaded axis metric structures.

## REVIEW THE RESULTS:

Once the solution has been calculated, we can use the ANSYS postprocessor to review the results. Two postprocessors are available: POST1 and POST 26. We use POST 1, the general postprocessor to review the results at one sub step over the entire model or selected portion of the model. We can obtain contour displays, deform shapes and tabular listings to review and interpret the results of the analysis. POST 1 offers many other capabilities, including error estimation, load case combination, calculation among results data and path operations.

We use POST 26, the time history post processor, to review results at specific points in the model over all time steps. We can obtain graph plots of results, data vs. time and tabular listings. Other POST 26 capabilities include arithmetic calculations and complex algebra.

In the solution of the analysis the computer takes over and solves the simultaneous set of equations that the finite element method generates, the results of the solution are

- Nodal degree of freedom values, which form the primary solution
- Derived values which form the element solution

## MESHING:

Before meshing the model and even before building the model, it is important to think about whether a free mesh or a mapped mesh is appropriate for the analysis. A free mesh has no restrictions in terms of element shapes and has no specified pattern applied to it.

Compare to a free mesh, a mapped mesh is restricted in terms of the element shape it contains and the pattern of the mesh. A mapped area mesh contains either quadrilateral or only triangular elements, while a mapped volume mesh contains only hexahedron elements. If we

want this type of mesh, we must build the geometry as series of fairly regular volumes and/or areas that can accept a mapped mesh.

## FREE MESHING:

In free meshing operation, no special requirements restrict the solid model. Any model geometry even if it is regular, can be meshed. The elements shapes used will depend on whether we are meshing areas or volumes. For area meshing, a free mesh can consist of only quadrilateral elements, only triangular elements, or a mixture of the two. For volume meshing, a free mesh is usually restricted to tetrahedral elements. Pyramid shaped elements may also be introduced in to the tetrahedral mesh for transitioning purposes.

## MAPPED MESHING

We can specify the program use all quadrilateral area elements, all triangular area elements or all hexahedra brick volume elements to generate a mapped mesh. Mapped meshing requires that an area or volume be “regular”, i.e., it must meet certain criteria. Mapped meshing is not supported when hard points are used. An area mapped mesh consists of either all quadrilateral elements or all triangular elements

For an area to accept a mapped mesh the following conditions must be satisfied:

- The area must be bounded by either three or four lines
- The area must have equal numbers of element divisions specified on opposite sides, or have divisions matching one transition mesh patterns.
- If the area is bounded by three lines, the number of element divisions must be even and equal on all sides
- The machine key must be set to mapped. This setting result in a mapped mesh of either all quadrilateral elements or all triangular elements depending on the current element type and shape key.

- Area mapped meshes shows a basic area mapped mesh of all quadrilateral elements and a basic area mapped mesh of all triangular elements

## STRUCTURAL ANALYSIS OF ROLLER CONVEYOR USING ALUMINIUM 3003 ALLOY

### Material properties

#### Composition of aluminium 3003 alloy

Atoms	Composition
Si	0.6
Fe	0.7
Cu	0.05-0.2
Mn	1-1.5
Zn	0.1
Al	Remaining

### Properties

Density: 2730 Kg/m<sup>3</sup>

Elastic modulus: 69GPa

Yield strength : 145MPa

Poisson ratio: 0.33

1. Thermal conductivity(k): 190W/Mk

2. Specific heat (Cp): 900 J/KgK

## STATIC ANALYSIS OF ROLLER CONVEYOR

### Boundary condition

Bottom plate of roller conveyor fixed with bolting connection and 750Kg (7500N) load acting on rollers in transmission of equipments.

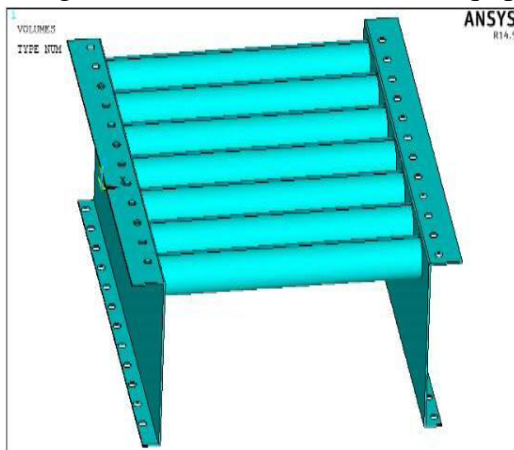

shows the imported model

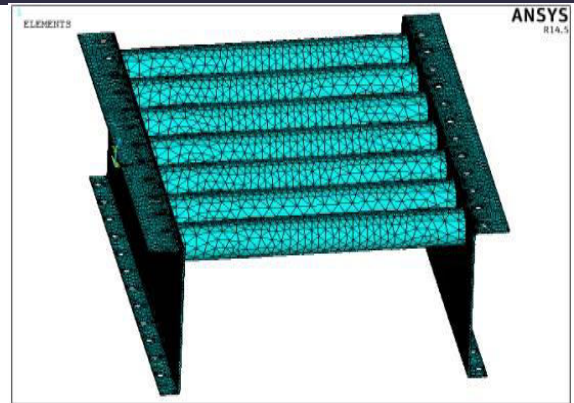

Fig: shows the meshing model

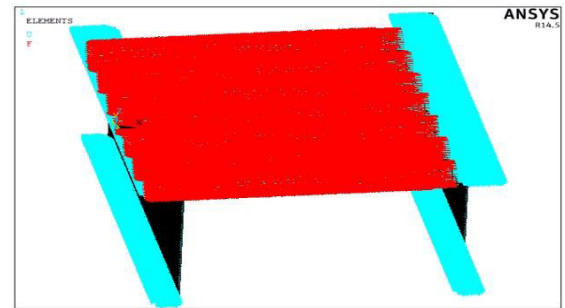

Fig: shows the boundary conditions of the model

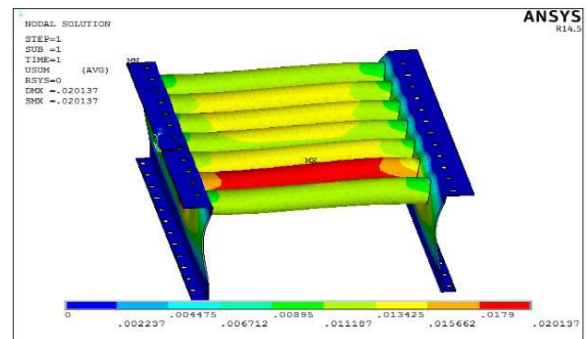

Fig: shows the maximum displacement

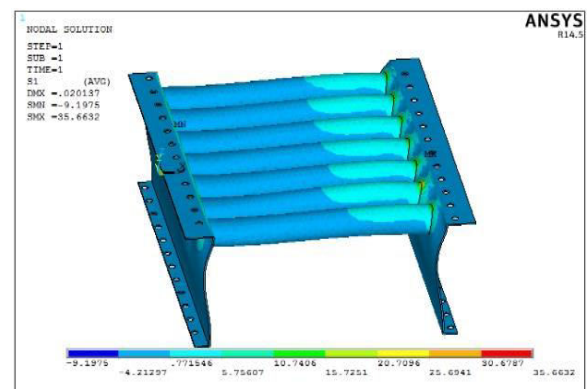

Fig:

Fig: shows the 1<sup>st</sup> principle of the stress

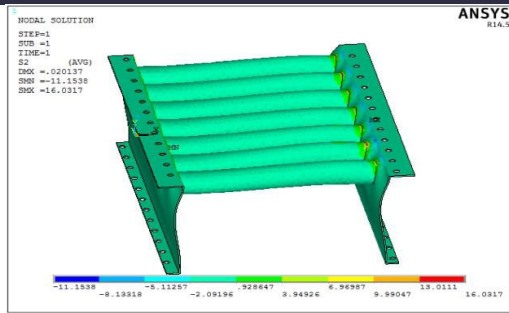

Fig: shows the 2<sup>nd</sup> principle of the stress



Fig: shows the meshing model

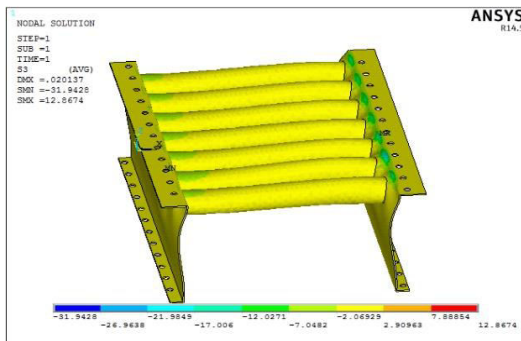

Fig: shows the 3<sup>rd</sup> principle of the stress

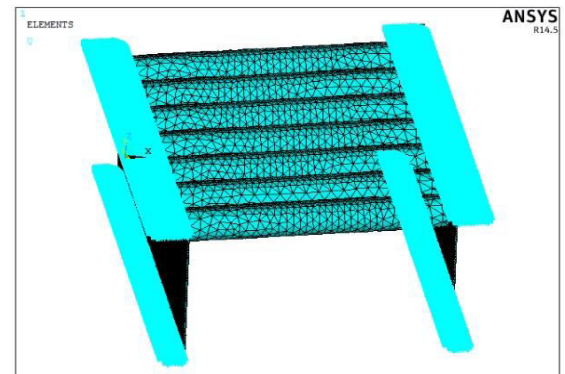

Fig: shows the boundary conditions

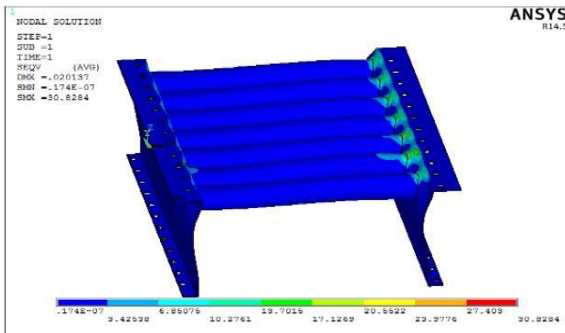
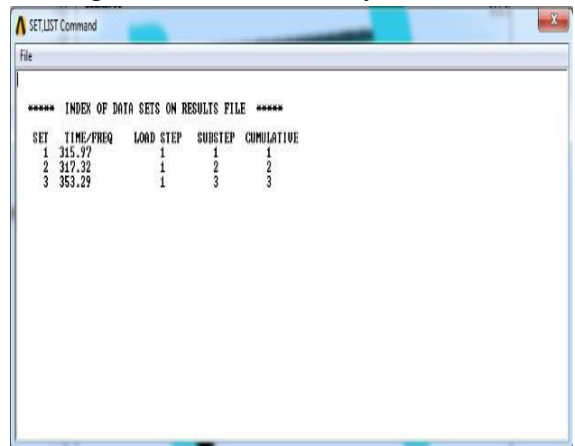

Fig: shows the stress on the body



## MODAL ANALYSIS OF ROLLER CONVEYOR

### Boundary condition

Bottom plate of roller conveyor fixed with bolting connection.

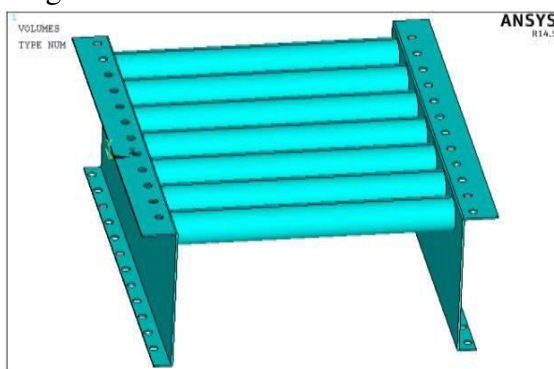

Fig: shows the imported model

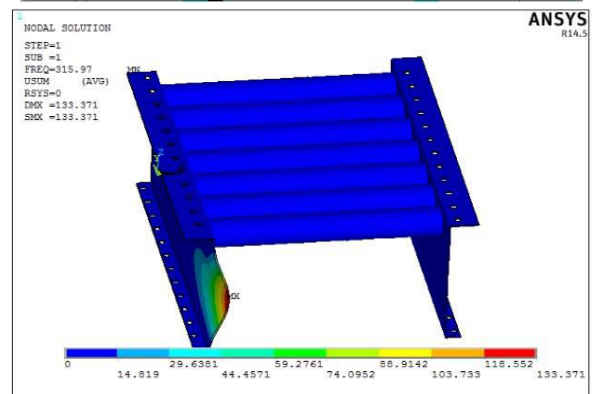

Fig: shows the 1<sup>st</sup> principle stress

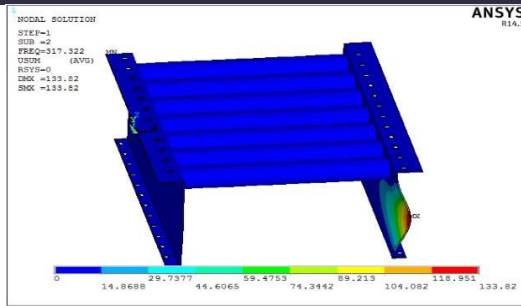

Fig: shows the 2<sup>nd</sup> principle stress

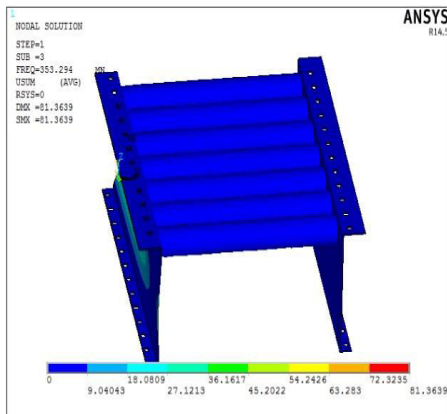

Fig: shows the 3<sup>rd</sup> principle stress

## STATIC ANALYSIS OF ROLLER CONVEYOR

### Boundary condition

Bottom plate of roller conveyor fixed with bolting connection and 750Kg (7500N) load acting on rollers in transmission of equipments.

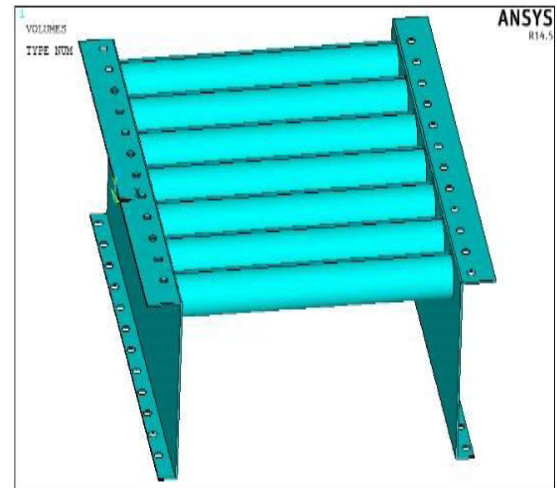

Fig: shows the imported model



Fig: shows the meshing model



Fig: shows the boundary conditions of the model

## STRUCTURAL ANALYSIS OF ROLLER CONVEYOR USING INCONEL MATERIAL

### Material properties

The following table shows mechanical properties of INCONEL 783.

Properties	Metric
Tensile strength	1194 MPa
Yield strength	779 MPa
Poisson's ratio	0.31
Elastic modulus	177.3 GPA

Density : 7810Kg/m<sup>3</sup>

### Thermal Properties

The thermal properties of INCONEL 783 are tabulated below.

Properties	Metric
Thermal expansion co-efficient	10.08 $\mu\text{m}/\text{m}^\circ\text{C}$
Thermal conductivity	10.1 W/m- $^\circ\text{C}$
Specific Heat Capacity	0.455 J/g- $^\circ\text{C}$



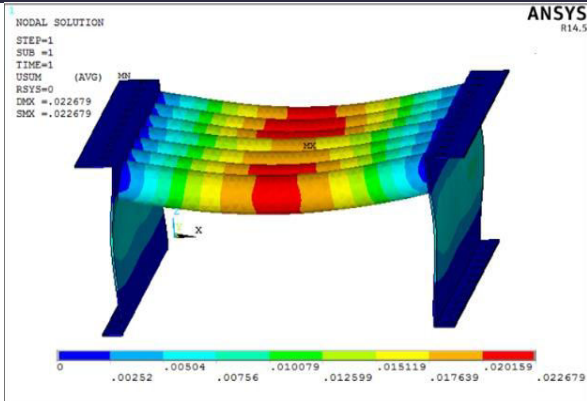

Fig: shows the maximum displacement of body

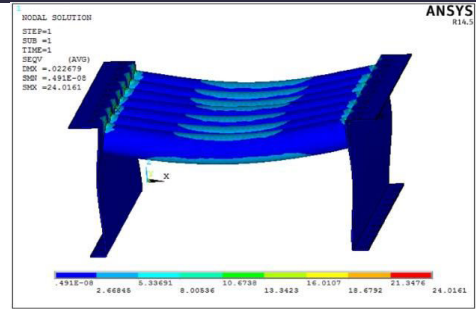

Fig: shows the resultant stress

## 4.3.2 MODAL ANALYSIS OF ROLLER CONVEYOR

### Boundary condition

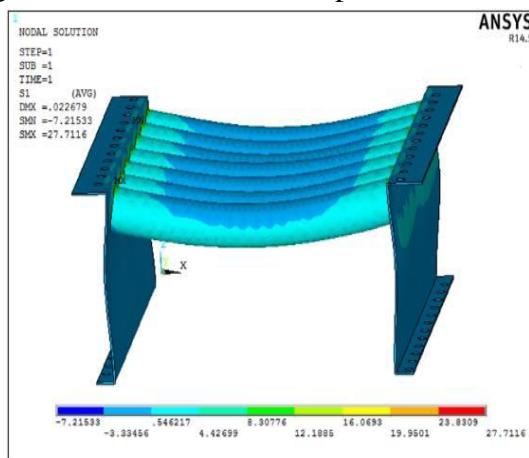

Fig: the 1<sup>st</sup> principle stress

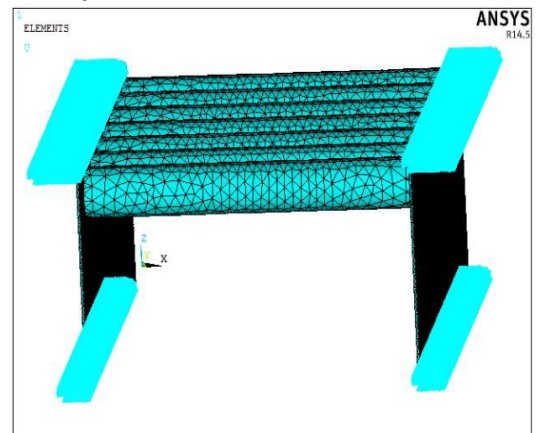

Fig: shows the boundary conditions

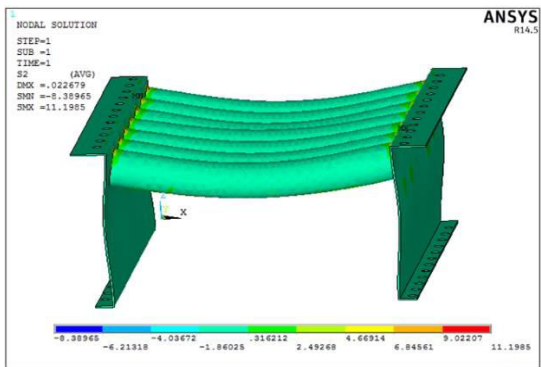

Fig: the 2<sup>nd</sup> principle stress

SET,LIST Command

```

  ***** INDEX OF DATA SETS ON RESULTS FILE *****
  SET  TIME/FREQ  LOAD STEP  SUBSTEP  CUMULATIVE
  1     299.36    1           1         1
  2     299.58    1           2         2
  3     334.68    1           3         3
  
```

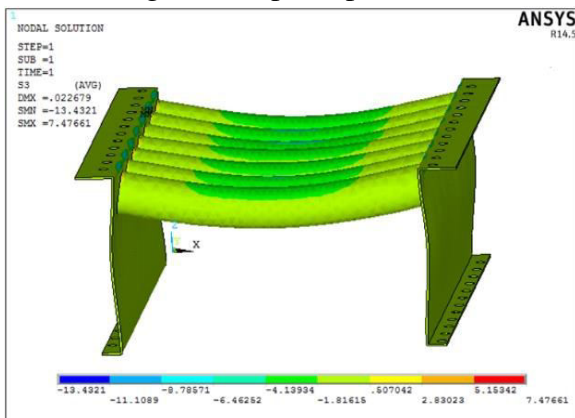

Fig: the 3<sup>rd</sup> principle stress

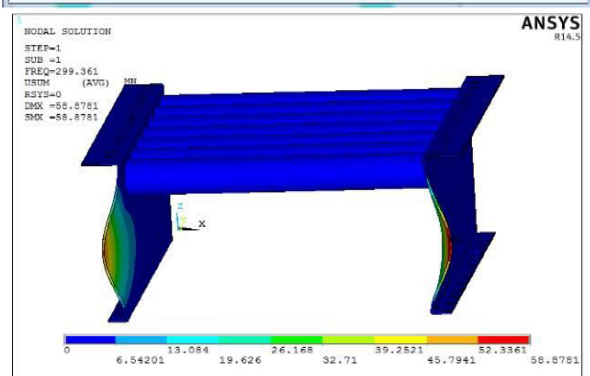

Fig: shows the maximum displacement

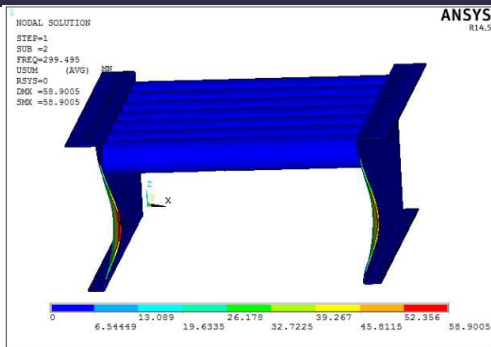

Fig: shows the maximum displacement at 2<sup>nd</sup> principle

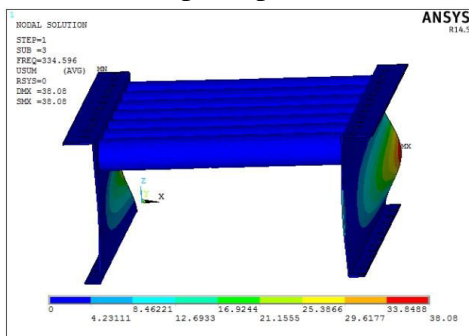

Fig: shows the maximum displacement at 3<sup>rd</sup> principle

## RESULT AND CONCLUSION

In this project roller conveyor analysis was studied briefly by using different materials. Analysis results are given below.

### STRUCTURAL ANALYSIS OF ROLLER CONVEYOR USING ALUMINIUM 3003 ALLOY

01	Maximum stress on the body(MPa)	30.8284
----	---------------------------------	---------

### MODAL ANALYSIS

01	Modal analysis of 1 <sup>st</sup> frequency	315
02	Modal analysis of 3 <sup>rd</sup> frequency	355

### STRUCTURAL ANALYSIS OF ROLLER CONVEYOR USING INCONEL MATERIAL

01	Maximum stress on the body(MPa)	24.01
----	---------------------------------	-------

### MODAL ANALYSIS OF ROLLER CONVEYOR

01	Modal analysis of 1 <sup>st</sup> frequency	299.361
02	Modal analysis of 3 <sup>rd</sup> frequency	344.596

From analysis results concluded that conveyor with inconel material formed less stress and less frequency range. It is the best material under loading condition.

## REFERENCES

- [1]. M. A. Alspaugh, "Latest Developments in Belt Conveyor Technology" MINExpo 2004, Las Vegas, NV, USA. September 27, 2004
- [2]. S.H. Masood · B. Abbas · E. Shayan · A. Kara "An investigation into design and manufacturing of mechanical conveyors Systems for food processing", Springer-Verlag London Limited 2004
- [3]. Dima Nazzal , Ahmed El-Nashar "Survey Of Research In Modeling Conveyor-Based Automated Material Handling Systems In wafer fabs" Proceedings of the 2007 Winter Simulation Conference.
- [4]. Chun-Hsiung Lan, "The design of a multi-conveyor system for profit maximization" International Journal Adv Manuf Technol (2003) 22: 510–521.
- [5]. John Usher, John R, G. Don Taylor "Availability modeling of powered roller conveyors".
- [6]. Espelage W, Wanke E. "Movement minimization for unit distances in conveyor flow shop processing",
- [7]. C.Sekimoto "Development of Concept Design CAD System", Energy and Mechanical Research Laboratories, Research and Development Center, Toshiba Corporation.
- [8]. Ying WANG, Chen ZHOU "A Model and an analytical method for conveyor system in distribution centers", J Syst Sci Syst Eng (Dec 2010) 19(4): 408- 429.
- [9]. R. Long, T. Rom, W. H'ansel, T.W. H'ansch, J. Reichel "Long distance magnetic conveyor for precise positioning of ultra cold atoms" Eur. Phys. J. D 35, 125–133 (2005).