



International Journal for Innovative Engineering and Management Research

A Peer Reviewed Open Access International Journal

www.ijiemr.org

COPY RIGHT

2017 IJIEMR. Personal use of this material is permitted. Permission from IJIEMR must be obtained for all other uses, in any current or future media, including reprinting/republishing this material for advertising or promotional purposes, creating new collective works, for resale or redistribution to servers or lists, or reuse of any copyrighted component of this work in other works. No Reprint should be done to this paper, all copy right is authenticated to Paper Authors

IJIEMR Transactions, online available on 14th Nov 2017. Link

[:http://www.ijiemr.org/downloads.php?vol=Volume-6&issue=ISSUE-11](http://www.ijiemr.org/downloads.php?vol=Volume-6&issue=ISSUE-11)

Title: **SIMULATION OF EMBEDDED Z – SOURCE INVERTER FED 3 – PHASE INDUCTION MOTOR DRIVE WITH APPROACH OF VARIOUS CONTROL STRATEGIES**

Volume 06, Issue 11, Pages: 81–88.

Paper Authors

¹SUNDARI SRAVAN KUMAR, ²Dr. YERRA SREENIVASA RAO

¹Shri Jagdish Prasad Jhabarmal Tibrewala University, Vidyanagari, Jhunjhunu, Rajasthan

²BVSR Engineering College, Chimakurthy, Ongole, A.P



USE THIS BARCODE TO ACCESS YOUR ONLINE PAPER

To Secure Your Paper As Per **UGC Guidelines** We Are Providing A Electronic Bar Code

SIMULATION OF EMBEDDED Z – SOURCE INVERTER FED 3 – PHASE INDUCTION MOTOR DRIVE WITH APPROACH OF VARIOUS CONTROL STRATEGIES

¹SUNDARI SRAVAN KUMAR, ²Dr. YERRA SREENIVASA RAO M.Tech, Ph.D

¹Assistant Professor, Dept of E.E.E, Shri Jagdish Prasad Jhabarmal Tibrewala University, Vidyanagari, Jhunjhunu, Rajasthan

²Principal, BVSr Engineering College, Chimakurthy, Ongole, A.P

ABSTRACT: Z-source inverters have recently been proposed as an alternative power conversion concept for adjustable speed AC drives (ASD) with both voltage buck and boost capabilities as they allow inverters to be operated in the shoot through state. This paper investigates the transient performance of vector controlled Z-source inverter-fed three-phase induction motor drive. The indirect vector controlled Z-source inverter based approach is presented in this paper. It provides a platform to control the induction motor just like a separately excited DC motor. The simulation has been carried out on a 1.5 hp 50 Hz induction motor using MATLAB/Simulink and resulting waveforms corresponding to different step conditions are presented to demonstrate the effectiveness of the proposed scheme. We find that the over shoot speed and settling time is in limit and the stator current is constant at variable speed conditions at full load and no load.

Keywords: Induction Motor Drives, Vector Control, Z-Source Inverter conventional Inverter, VSI, LC filter

1. INTRODUCTION

The traditional voltage source inverter (VSI) consists of a diode rectifier front end, DC link and inverter bridge. The VSI uses buck topology which has characteristic that the average output voltage is always lower than input DC voltage. Thus, if an output voltage higher than input voltage is needed, a boost DC-DC converter must be used between the DC source and inverter. Depending on the power and voltage levels, this can result in higher volume, weight, cost and reduced efficiency. A conventional VSI drive is shown in Figure 1. The voltage source converter is widely used but has the

following conceptual and theoretical barriers and limitations: [1]

- The AC output voltage is limited below and cannot exceed the DC bus voltage. The voltage source converter is a boost rectifier for AC to DC power conversion.
- The upper and lower devices of each phase leg cannot be switched on simultaneously. Otherwise, a shoot through would occur and destroy the devices. Dead-time to block both upper and lower devices has to be provided in the voltage source

converter, which causes waveform distortion, etc.

- An output LC filter is needed for providing a sinusoidal voltage compared with the current source inverter which causes additional power loss and control complexity.
- It is vulnerable to RFI noise in terms of reliability.

A smooth speed control is primary requirement of any industrial drive. The various control strategies for inverter fed induction motor have provided good steady state but poor dynamic response. Z-source fed induction motor drive has been simulated using indirect vector control approach. The control system has been realized in synchronous reference frame. The study of drive dynamics has been carried out by applying two changing operating conditions to the drive: a step change in speed reference and a step change in load torque. The simulation results show the excellent performance in both transient state and steady state condition at different load condition of three phase induction motor. The induction motor has been fed from a Z-source inverter which has several advantages over conventional converters like voltage source converter and current source converters. The theoretical barriers and limitations of VSI and CSI are overcome by Z-source inverter. It provides the ability of a power source to deliver usable power for a limited time during a power loss which is also known as ride through capability during voltage sags, reduces the line harmonics, improves power factor, increases reliability and extends

output voltage range. The indirect vector controlled induction motor drive provides decoupling of the stator current into torque and flux producing components. Possibly, it is the best among all the control techniques for variable speed applications. This proposed strategy greatly reduces the complexity and cost when compared with traditional systems or conventional systems.

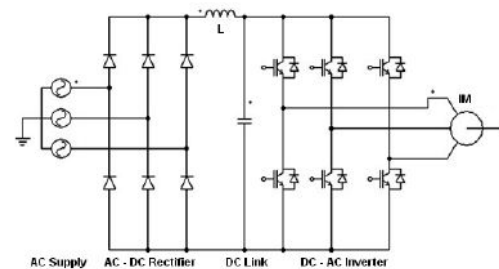

Figure 1 Conventional VSI drive with front end Rectifier

2. FUNDAMENTAL OF Z-SOURCE INVERTER

Z-source inverter is used to overcome the problems in the traditional inverters by employing a unique impedance network coupled with the inverter main circuit to the power source. The AC voltage is rectified to DC voltage by the rectifier and the rectifier output DC voltage fed to the impedance network, which consists of two equal inductors and two equal capacitors. In this second order filter network, inductors are connected in series arms and capacitors are connected in diagonal arms for decrease or increase the input voltage and this network also acts as a second order filter (A Z-source inverter fed induction motor drive is shown in Figure 2). The unique feature of the Z-source inverter is the wide range of voltage control with the output AC voltage of any value between zero and infinity regardless of DC voltage. The traditional three-phase voltage source inverter has six active vectors

when the DC voltage is impressed across the load and two zero vectors. A zero state is produced when the upper three or lower three switches are turned on at the same time, shorting the output terminals. However, three-phase Z-source inverter bridge has one extra zero state when the load terminals are shorted through both the upper and lower devices of any one phase leg, any two phase legs, or all three phase legs. This shoot-through zero state is forbidden in the traditional voltage source inverter, because it would cause a short circuit. The Z-source network makes the shoot-through zero state efficiently utilized throughout the operation [3]-[4]. The Z-source network is a combination of two inductors and two capacitors. This combined circuit, the Z-source network is the energy storage/filtering element for the Z-source inverter. The Z-source network is more effective to suppress voltage and current ripples than capacitor or inductor used alone in the traditional inverters.[2] When the two inductors (L1 and L2) are small and approach zero, the Z-source network reduces to two capacitors (C1 and C2) in parallel and becomes a traditional voltage-source. Therefore, a traditional voltage-source inverter's capacitor requirements and physical size is the worst case requirement for the Z-source network.[11]

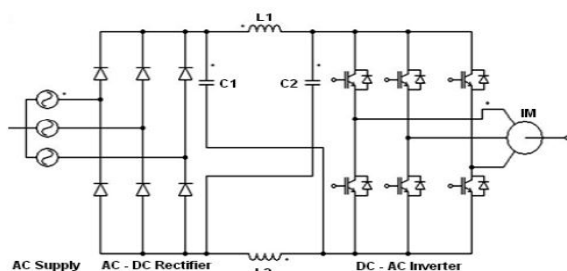

Figure 2 Z-source inverter fed induction motor drive

Considering additional filtering and energy storage provided by the inductors, the Z-source network should require less capacitance and smaller size compared with the traditional VSI. Similarly, when the two capacitors (C1 and C2) are small and approach zero, the Z-source network reduces to two inductors (L1 and L2) in series and becomes a traditional currentsource. Therefore, a traditional current-source inverter's inductor requirements and physical size is the worst case requirement for the Z-source network. Considering additional filtering and energy storage by the capacitors, the Z-source network should require less inductance and smaller size compared with the traditional current-source inverter. The Z-source inverter employs some features that traditional VSI and CSI cannot provide. The Z-source converter overcomes the conceptual and theoretical barriers and limitations of the traditional VSI and CSI and provides a novel power conversion concept. The Z-source concept can be easily applied to ASD systems. The Z-source rectifier/inverter system can produce an output voltage greater than the AC input voltage is the feature that is not present in the traditional converters

3. VECTOR CONTROL APPROACH METHOD

3.1 Advantages:-

- Stable operation with large motors.
- Better performance at current limit with improved slip control.
- Decrease in the losses of the machine.
- Excellent speed control with inherent slip compensation.

- High torque at low speeds.
- Increase in the overall performance of the motor.

The various control strategies for the control of inverter-fed induction motor have provide good steady-state but poor dynamic response, which results that the air-gap flux linkage deviate from its set values, not only in magnitude but also in phase. This oscillation in the air gap flux linkage results in oscillations in electromagnetic torque and hence in speed oscillations. There are many methods to control the three-phase induction motor discussed in [5]-[10]. In vector control method three-phase current vectors are converted to a two-dimensional rotating reference frame $d \square q$ from a three-dimensional stationary reference frame. The d component represents the flux producing component of the stator current and the q component represents the torque producing component. These two decoupled components can be independently controlled by passing through separate PI controller. The outputs of the PI controllers are transformed back to the three dimensional stationary reference plane using the inverse of the Clarke-Park transformation. In vector control an assumption is made that the position of rotor flux linkages r field angle), and the stator current can be transformed in q and d axes.) Currents in synchronous reference frame can be obtained by using the transformation:

$$\begin{bmatrix} I_q^e \\ I_d^e \end{bmatrix} = \frac{2}{3} \begin{bmatrix} \sin\theta_f & \sin\left(\theta_f - \frac{2\pi}{3}\right) & \sin\left(\theta_f + \frac{2\pi}{3}\right) \\ \cos\theta_f & \cos\left(\theta_f - \frac{2\pi}{3}\right) & \cos\left(\theta_f + \frac{2\pi}{3}\right) \end{bmatrix} \begin{bmatrix} i_a \\ i_b \\ i_c \end{bmatrix} \quad (1)$$

From (1) i_q and i_d can be given as

$$i_d = \sqrt{(I_q^e)^2 + (I_d^e)^2} \quad (2)$$

$$\theta_f = \tan^{-1} \frac{I_q^e}{I_d^e} \quad (3)$$

Where, I_q^e and I_d^e are the q and d axes currents in synchronous reference frame. The current phasor i_d produces the rotor flux λ_r and the torque T_e . The component i_d is field producing component, the rotor flux phasor is in phase with λ_r and component i_q is torque producing component.

$$\lambda_r \propto i_d \quad (4)$$

$$T_e \propto \lambda_r i_q \propto i_d i_q \quad (5)$$

The instantaneous rotor flux position θ_f can be given as- (Where, θ_r = rotor position angle)

$$\theta_f = \theta_r + \theta_d \quad (6)$$

The steady state flux linkage are evaluated from the steady state currents; they in turn are found out by using synchronous reference frame equations with the substitution of $p=0$ and the slip speed being zero. [12] Because the slip speed is zero, the machine does not produce electromagnetic torque; thus the stator current is utilized solely to produce stator and rotor flux linkages.

$$\begin{bmatrix} I_{qs} \\ I_{ds} \\ I_{qr} \\ I_{dr} \end{bmatrix} = \begin{bmatrix} R_s & \omega_s L_s & 0 & \omega_s L_m \\ -\omega_s L_s & R_s & -\omega_s L_m & 0 \\ 0 & \omega_{sl} L_m & R_r & \omega_{sl} L_r \\ -\omega_{sl} L_m & 0 & -\omega_{sl} L_r & R_r \end{bmatrix}^{-1} \begin{bmatrix} V_{qs} \\ V_{ds} \\ 0 \\ 0 \end{bmatrix} \quad (7)$$

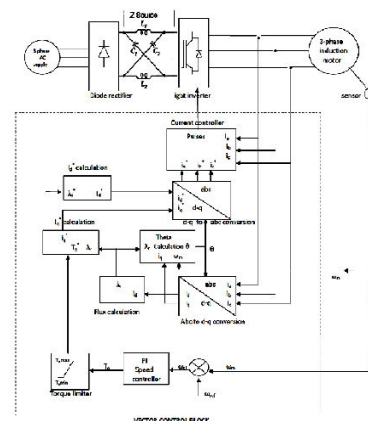

Figure 3 Block diagram of Vector Controlled Z-Source Inverter-fed Induction Motor Drive.

$$\lambda_{qr} = L_m I_{qr} + L_r I_{qr} \quad (8)$$

$$\lambda_{dr} = L_m I_{dr} + L_r I_{dr} \quad (9)$$

$$\lambda_r = \sqrt{(\lambda_{qr})^2 + (\lambda_{dr})^2} \quad (10)$$

$$\lambda_{qs} = L_s I_{qs} + L_m I_{qr} \quad (11)$$

$$\lambda_{ds} = L_s I_{ds} + L_m I_{dr} \quad (12)$$

$$\lambda_s = \sqrt{(\lambda_{qs})^2 + (\lambda_{ds})^2} \quad (13)$$

When vector control technique is implemented on induction motor and provides ease in control just like the control of separately excited DC machine. It is compared by other control techniques like scalar and direct torque control and found to be better and more effective than other techniques.

4. SYSTEM DESCRIPTION AND SIMULATION SETUP

Suitability of any drive for an application depends on its behavior under transient and steady state conditions. To study the behavior a MATLAB/Simulink model is developed to examine the transient performance of the induction motor drive. The simulations use the parameters of the 1.5 hp 50 Hz induction motor. The schematic block diagram of complete drive system is shown in Figure 3. The vector controlled Z-source inverter-fed induction motor drive consists of a three-phase AC source, a three-phase diode rectifier, a Z-source inverter and a three-phase squirrel cage induction motor with load. The vector control block consist of PI speed controller, theta calculation block ABC to d-q transformation block, Id* calculation block, Iq* calculation block, flux calculation block, d-q to ABC transformation block and a current regulator block. A MATLAB/Simulink model is developed to examine the transient performance of vector

controlled Z-source inverter fed three-phase induction motor drive. The performance of the induction motor has been studied utilizing the parameters of the actual system which is described in Appendix-I.

5. RESULTS AND DISCUSSION

The effectiveness of the controller can be analyzed by considering the response of motor speed, torque and current for each alteration in reference speed and load torque. Figures 4-6 show the transient performance curves of drive the for successive step changes in reference speed and torque after each interval of 0.5 seconds of complete drive operation. The three-phase stator current response is shown in Figure 4, the speed response is shown in Figure 5 and Figure 6 shows the torque response of the drive when the reference speed or load torque is increased and/or decreased instantaneously after each interval of 0.5 seconds. Firstly the speed have been step accelerated from 500 to 1000 rpm and then from 1000 to 1415 rpm and then step decelerated from 1415 to 1000 rpm and then from 1000 to 500 rpm.

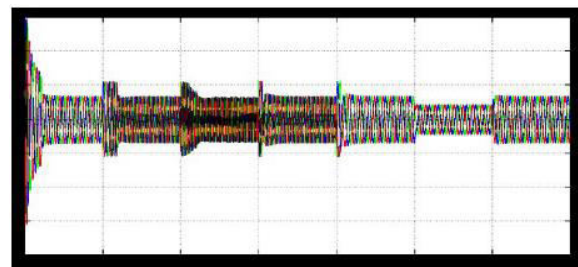

Figure 4 The waveform of 3-phase stator current I_{abc} .

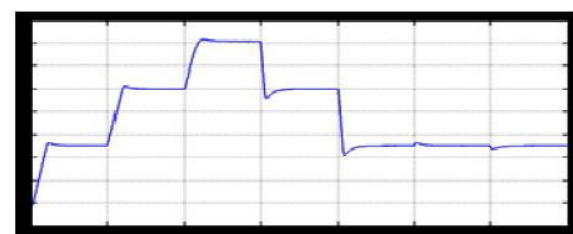

Figure 5 The combine waveform of rotor speed in rpm

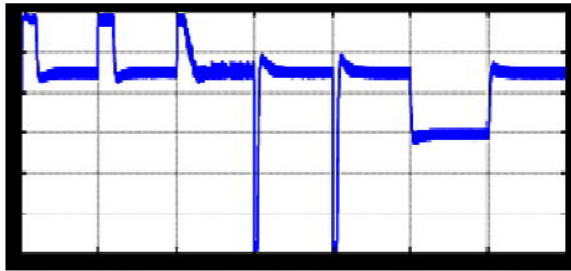

Figure 6 The waveform of electromagnetic torque in N-m

The percentage overshoot and settling time for vector controlled Z-source inverter-fed induction motor drive when subjected to different transient conditions are shown in Table 1.

- In the I case, the speed command has been given 500 rpm and the load torque is set at full load torque i.e. at 7.4 N-m for $t=0$ to 0.5 seconds. And it is observed that the RMS value of stator current comes to be 2.35 A. The settling time is 0.35 seconds and the overshoot of speed is only 5%.

Table 1 Different Motor parameters with Time

Case	Time (t) (sec)	Speed command (rpm)	Load command (N-m)	Stator current (A)	Speed overshoot (%)	Settling time (sec)
1	0	500	7.4	2.35	5	0.35
2	0.5	1000	7.4	2.35	2.6	0.37
3	1.0	1415	7.4	2.35	1.41	0.36
4	1.5	1000	7.4	2.35	8.3	0.32
5	2.0	500	7.4	2.35	16.6	0.33
6	2.5	500	0	1.43	5.8	0.32
7	3.0	500	7.4	2.35	16.6	0.33

- In the II case, response are obtained keeping the load torque at 7.4 N-m as in earlier case but this time the speed command is accelerated to 1000 rpm as time reaches 0.5 second up to 1 second. It is observed that the

settling time in this case is 0.37 seconds and the speed overshoot is

2.6%. The RMS value of three phase stator current remains the same at 2.35A.

- In Case III, speed command is increased to 1415 rpm as soon as time reaches 1 second for the next 0.5 seconds. This time also the load torque remains the same i.e. 7.4 N-m. The settling time is 0.36 sec and the remarkable overshoot of speed is only 1.41%. The RMS value of stator current remains unchanged at 2.35 A.
- In case IV the speed command is decelerated from 1415 rpm to 1000 rpm by maintaining the load torque at 7.4N-m at $t=1.5$ sec. for the next 0.5 second and it has been observed that the speed firstly reduces to 917 rpm and then settles to 1000 rpm within 0.32 seconds. The overshoot is 8.3%. RMS value of stator current is 2.35 again.
- In Case V, speed is further decreased from 1000 rpm to 500 rpm at $t=2$ seconds. The load torque is 7.4 N-m and stator current is 2.35 A. The speed overshoot is 16.6%.
- In case VI, speed command is set at 500 rpm and now the load torque is made 0 i.e. at no load at the instant $t=2.5$ seconds. In this particular case the rms value of stator current decrease to 1.43 A which was 2.35 A in earlier cases. The overshoot for this is 5.8%. The

settling time is 0.32 sec counts further from the instant when command was given.

- In case VII, the speed command remains the same i.e. at 500 rpm and load torque is increased from no load to full load i.e. at 7.4 N-m. The stator current attains the RMS value of 2.35 A again and speed settles at $t=0.31$ second from the instant of providing command i.e. from $t= 3.0$ seconds. The overshoot is 16.6% of command speed.

6. CONCLUSION

A closed-loop scheme of vector controlled Z-source inverter-fed induction motor drive was presented. The control system was realized in synchronous reference frame. The study of drive dynamics was carried out by applying two changing operating conditions to the drive: a step change in speed reference and a step change in load torque. The simulation results were obtained, and show the satisfactory performance at various transient conditions.

7. FUTURE SCOPE

This work can also be carried out for higher ratings of induction motor and also the current scheme may be implemented using AI techniques such as a fuzzy logic controller or ANN techniques.

References

[1] G. Pandian, and S. Rama Reddy, "Embedded Controlled Z-Source Inverter fed Induction Motor Drive," Journal of Applied Sciences Research, 4(7): 826-832, 2008, INSI net Publication.

[2] B. Justus Rabi and R. Arumugam, "Harmonics Study and Comparison of Z-source Inverter with Traditional Inverters" American Journal of Applied Sciences 2 (10): 1418-1426, 2005.

[3] Peng, F.Z., M. Shen, A. Joseph, L.M. Tolbert, and D. J. Adams, 2004. "Maximum Constant Boost Control of the ZSource Inverter," In proc. IEEE IAS'04.

[4] Fang Zheng Peng, 2003. Xiamoing yuvan, Xupeng Fang, and Zhaoiming Qian, "Z-source inverter for adjustable speed drives," proc. Of IEEE letter, 1(2): 33-35.

[5] R. A. Hamilton and G. R. Lezan, "Thyristor adjustable frequency power supplies for hot strip mill run-out tables," IEEE Trans. Ind. Gen. Applicat., vol. IGA-3, Mar./Apr. 1967, pp. 168-175.

[6] W. Slabiak, and L. Lawson, "Precise control of a three-phase squirrel cage induction motor using a practical Cycloconverter," IEEE Trans. Ind. Gen. Applicat. vol. IGA-2, July/Aug. 1966, pp. 274-280.

[7] W. Shepherd and J. Stanway, "An experimental closed-loop variable speed drive incorporating a thyristor driven induction motor," IEEE Trans. Ind. Gen. Applicat., vol. IGA-3, Nov./Dec, pp. 559-565.

[8] Rakesh Parekh AN887 AC, "Induction Motor Fundamentals," Microchip Technology Inc.

[9] Dong-Choon Lee, and G. Myoung Lee, "A Novel Over-modulation Technique for Space-Vector PWM Inverters," IEEE Transactions on Power Electronics, Vol. 13, No. 6, November 1998.



[10] J. Rodriguez, J. S. Lai, and F. Z. Peng, "Multilevel converters: a survey of topologies, controls, and applications," *IEEE Trans. Industrial Electronics*, vol. 49, no. 4, pp. 724-738, Aug. 2002.

[11] Peng F. Z. "Z-Source Inverter" *IEEE Transactions on Industry Applications*, vol. 39, no.2, pp.504-510, March/April 2003.

[12] R.Krishanan, "Electric motor drives modeling, analysis, and control," Pearson education.

[13] Baburaj Karanayil, Muhammed Fazlur Rahman and Colin Grantham, "Online Stator and Rotor Resistance Estimation Scheme Using Artificial Neural Networks for Vector Controlled Speed Sensor less Induction Motor Drive" *IEEE transactions on industrial electronics*, vol.54,no.1,February2007.