



International Journal for Innovative Engineering and Management Research

A Peer Reviewed Open Access International Journal

www.ijiemr.org

COPY RIGHT



ELSEVIER
SSRN

2020 IJIEMR. Personal use of this material is permitted. Permission from IJIEMR must be obtained for all other uses, in any current or future media, including reprinting/republishing this material for advertising or promotional purposes, creating new collective works, for resale or redistribution to servers or lists, or reuse of any copyrighted component of this work in other works. No Reprint should be done to this paper, all copy right is authenticated to Paper Authors

IJIEMR Transactions, online available on 18th Dec 2020. Link

[:http://www.ijiemr.org/downloads.php?vol=Volume-09&issue=ISSUE-12](http://www.ijiemr.org/downloads.php?vol=Volume-09&issue=ISSUE-12)

DOI: 10.48047/IJIEMR/V09/I12/50

Title: **VOLTAGE SAG COMPENSATION USING SYNCHRONOUSLY REFERENCE FRAME THEORY BASED DYNAMIC VOLTAGE RESTORER**

Volume 09, Issue 12, Pages: 288-292

Paper Authors

V.SHAILAJA, M.SAHITHYA, A.MANISHA, G.AMRUTHA, P.PRAMADA KUMARI



USE THIS BARCODE TO ACCESS YOUR ONLINE PAPER

To Secure Your Paper As Per **UGC Guidelines** We Are Providing A Electronic Bar Code

VOLTAGE SAG COMPENSATION USING SYNCHRONOUSLY REFERENCE FRAME THEORY BASED DYNAMIC VOLTAGE RESTORER

V.SHAILAJA¹ M.SAHITHYA² A.MANISHA³ G.AMRUTHA⁴ P.PRAMADA KUMARI⁵

^{1,2,3,4} B TECH Students, Department of EEE, Princeton Institute of Engineering & Technology For Women, Hyderabad, Telangana, India.

⁵ Assistant Professor, Department of EEE, Princeton Institute of Engineering & Technology For Women, Hyderabad, Telangana, India.

ABSTRACT:

This research checks out using superconducting magnetic and also battery crossbreed power storage space to make up grid voltage changes. The superconducting magnetic power storage space system has actually been imitated by a high-current inductor to examine a system utilizing both SMES and also battery power storage space experimentally. The style of the research laboratory model is explained carefully, which includes a series-connected 3 stage voltage resource inverter utilized to control air conditioner voltage, and also 2 bidirectional dc/dc converters made use of to regulate power storage space system fee and also discharge. "DC bus degree signaling" and also "voltage droop control" have actually been made use of to instantly manage power from the magnetic power storage space system throughout short-duration, high-power voltage droops, while the battery is utilized to offer power throughout longer term, low-power under voltages.

Keywords: SMES, Ultra capacitor, Battery energy storage system, high voltage, sag and swell.

1. INTRODUCTION:

Power top quality problems are split right into 2 groups' voltage high quality as well as regularity top quality. Voltage top quality problems are associated with voltage droop, voltage swell, under voltage as well as over voltage while regularity top quality concerns are connected with harmonics and also transients. Among one of the most important power top quality problems is voltage droop which is take place as a result of its use of voltage delicate tools. It has actually made industrials refines much more vulnerable to provide voltage droops [1] The

DVR gadget includes 5 major areas; (i) Energy Storage Unit: It is in charge of power storage space in DC kind. Flywheels, lead acid batteries, Superconducting Magnetic Energy Storage (SMES) as well as Super-Capacitors could be utilized as power storage space gadgets, the quotes of the regular power effectiveness of 4 power storage space innovation. Electric power storage space gadgets come under indirect power storage space classifications. The kept power is reconverted back to electric power, when a supply of electric power is needed, it is hard to shop as well as

reconvert huge quantity of power. Numerous power storage space gadgets are currently utilized for voltage droop payment in the DVR system. Electric power storage space gadgets are extremely capacitor, superconducting magnetic power storage space (SMES) and so on. Dynamic voltage repair (DVR) is an approach of conquering voltage droops that happen in electric power circulation. These are an issue since spikes eat power as well as droops minimize effectiveness of some tools. DVR conserves power with voltage shots that could impact the stage as well as wave-shape of the power being provided. Instruments for DVR consist of fixed var gadgets, which are collection payment gadgets that make use of voltage resource converters (VSC).

power materials (UPS), shunt attached compensators, or vibrant voltage conservator (DVR) systems. Faucet transforming transformers have actually been revealed to deal with a slow-moving feedback time and also could just outcome distinct voltage degrees. UPS systems give the full voltage waveform throughout a power failing as well as could verify expensive as well as unneeded in case of partial voltage droops. A DVR is a collection attached tool with the ability of voltage settlement with quick reaction time by infusing a voltage in collection with the supply. DVR systems could be independent using power from the Grid to alleviate disruptions. Conversely, DVR systems could make use of power storage space to give power throughout settlement such as capacitors for temporary storage space or batteries for longer-term storage space. The fundamental concept of the vibrant voltage conservator is to infuse a voltage of called for size as well as regularity, to ensure that it could bring back the lots side voltage to the preferred amplitude as well as waveform also when the resource voltage is out of balance or altered. Typically, it utilizes a gateway shut off thyristor (GTO) strong state power digital buttons in a pulse size regulated (PWM) inverter framework.

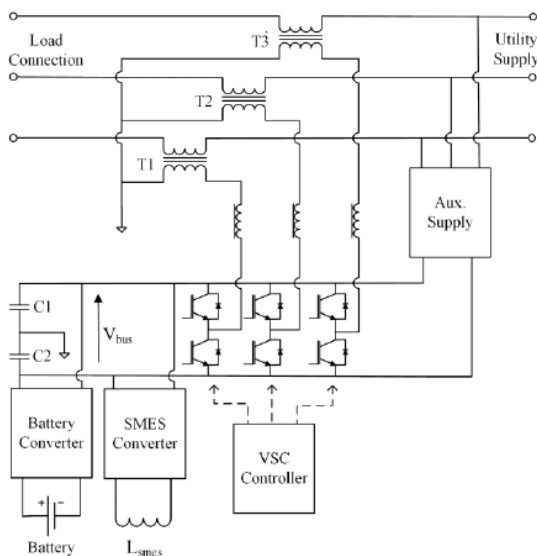

Fig.1.1. Model diagram.

2. PREVIOUS STUDY:

Supply voltage could be secured by faucet transforming transformers, uninterruptable

3. PROPOSED SYSTEM:

This job takes a look at making use of superconducting magnetic and also battery crossbreed power storage space to make up grid voltage Fluctuations. The superconducting magnetic power storage

space system (SMES) has actually been mimicked by a high-current inductor to explore a system using both SMES and also battery power storage space experimentally. The style of the lab model is defined carefully, which includes a series-connected 3 stage voltage resource inverter made use of to control air conditioner voltage, as well as 2 bidirectional dc/dc converters utilized to regulate power storage space system fee and also Discharge. "DC bus degree signalling" and also "voltage droop control" have actually been utilized to immediately regulate power from the magnetic power storage space system throughout short-duration, high-power voltage droops, while the battery is utilized to give power throughout longer term, low-power under voltages. Power storage space system hybridization is revealed to be useful by minimizing battery top power need compared to a battery-only system, and also by boosting lasting voltage assistance capacity compared to an SMES-only system. Subsequently, the SMES/battery crossbreed vibrant voltage conservator could sustain both temporary high-power voltage droops and also lasting under voltages with substantially lowered superconducting product expense compared to an SMES-based system.

4. SIMULATION RESULTS:

Temporary voltage settlement alone could not suffice to safeguard delicate tons as both long-lasting and also temporary voltage security has actually been revealed to offer an issue for lots of customers. Consequently,

this research study takes into consideration making use of SMES/battery crossbreed power storage space to make up lengthy as well as temporary voltage variations. Wong et al. have actually additionally taken into consideration a SMES/battery crossbreed as well as revealed it is sensible for smoothing of renewable resource generator result power as well as could lead to lowered power storage space system ability and also extended battery life. Li et al. have actually revealed that a SMES/battery power storage space system could boost battery life time in electrical buses.

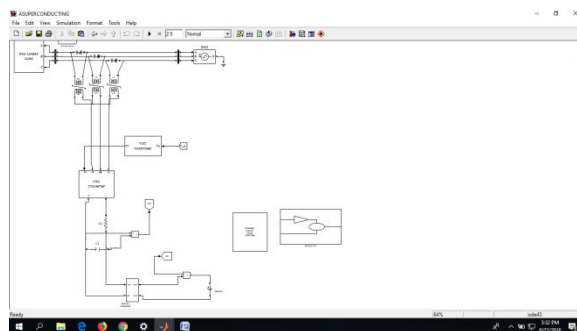

Fig.4.1. Simulation circuit.



Fig.4.2. Grid side voltage and current.

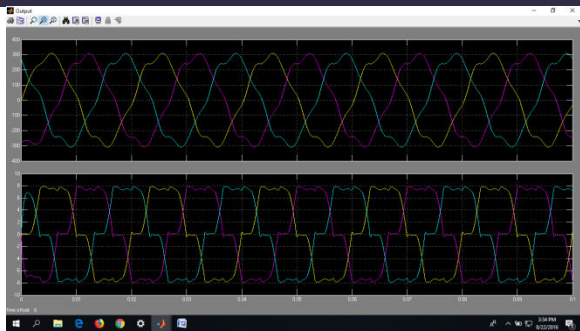

Fig.4.3. Load side voltage and currents.

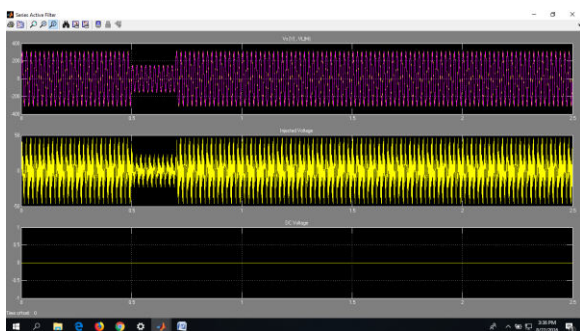

Fig.4.3. Voltage disturbances.

5. CONCLUSION:

The efficiency and unique crossbreed DVR system geography has actually been evaluated experimentally as well as revealed to properly supply voltage payment for temporary droops as well as long-lasting under-voltages. A model system has actually been established which shows an efficient technique of interfacing SMES and also battery power storage space systems to sustain a 3 stage lots. The system has actually been revealed to autonomously prioritise using the temporary power storage space system to sustain the tons throughout deep, temporary voltage droops and also a battery for reduced deepness, lasting under-voltages. This could have advantages in regards to enhanced voltage assistance

ability and also decreased expenses compared to a SMES-based system. Fringe benefits consist of lowered battery power ranking demand and also an anticipated renovation in battery life compared to a battery-only system because of decreased battery power biking as well as optimal discharge power

REFERENCES:

- [1] P.K. Ray, S.R. Mohanty, N. Kishor, as well as J.P.S. Catalao, "Optimal Feature as well as Decision Tree-Based Classification of Power Quality Disturbances in Distributed Generation Systems," Sustainable Energy, IEEE Trans., vol. 5, Sept. 2014, pp. 200-208.
- [2] D. Novosel, G. Bartok, G. Henneberg, P. Mysore, D. Tziouvaras, and also S. Ward, "IEEE PSRC Report on Performance of Relaying During Wide-Area Stressed Conditions," Power Delivery, IEEE Trans., vol. 25, Jan. 2010, pp. 3-16.
- [3] "IEEE Recommended Practice for Monitoring Electric Power Quality," in IEEE Std 1159-1995, ed. New York City, NY: IEEE Standards Board, 1995, p. i.
- [4] S. Jothibasu as well as M.K. Mishra, "A Control Scheme for Storageless DVR Based on Characterization of Voltage Sags," Power Delivery, IEEE Trans., vol. 29, July 2014, pp. 2261-2269
- [5] B. Otomega and also T. Van Cutsem, "Undervoltage Load Shedding Using Distributed Controllers," Power Systems, IEEE Trans., vol. 22, Nov. 2007, pp. 1898-1907.
- [6] L. Chun, J. Savulak, and also R. Reinmuller, "Unintentional Islanding of

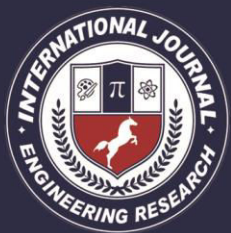

Distributed Generation: Operating Experiences From Naturally Occurred Events," *Power Delivery, IEEE Trans.*, vol. 29, Jan. 2014, pp. 269-274.

[7] S. Tohidi, H. Oraee, M.R. Zolghadri, S. Shiyi, as well as P. Tavner, "Analysis as well as Enhancement of Low-Voltage Ride-Through Capability of Brushless Doubly Fed Induction Generator," *Industrial Electronics, IEEE Trans.*, vol. 60, March 2013, pp. 1146-1155.

[8] R. Lawrence, "Voltage optimization," *Industry Apps. Mag., IEEE*, vol. 12, Sept. 2006, pp. 28-33.

[9] P. Kanjiya, B. Singh, A. Chandra, as well as K. Al-Haddad, "'SRF Theory Revisited" to Control Self-Supported Dynamic Voltage Restorer (DVR) for Unbalanced as well as Nonlinear Loads," *Industry Applications, IEEE Trans.*, vol. 49, May 2013, pp. 2330-2340.