



International Journal for Innovative Engineering and Management Research

A Peer Reviewed Open Access International Journal

www.ijiemr.org

COPY RIGHT

2017 IJIEMR. Personal use of this material is permitted. Permission from IJIEMR must be obtained for all other uses, in any current or future media, including reprinting/republishing this material for advertising or promotional purposes, creating new collective works, for resale or redistribution to servers or lists, or reuse of any copyrighted component of this work in other works. No Reprint should be done to this paper, all copy right is authenticated to Paper Authors

IJIEMR Transactions, online available on 3rd Nov 2017. Link

[:http://www.ijiemr.org/downloads.php?vol=Volume-6&issue=ISSUE-10](http://www.ijiemr.org/downloads.php?vol=Volume-6&issue=ISSUE-10)

Title: **ZCS BASED SOFT SWITCHING TECHNIQUE FOR MODULAR INVERTER FED BY PV-ARRAY**

Volume 06, Issue 10, Pages: 105–108.

Paper Authors

PALLE VAMSHI, M.D.IMRAN

Vaageswari College of Engineeirng Karimnagar, T.S, INDIA



USE THIS BARCODE TO ACCESS YOUR ONLINE PAPER

To Secure Your Paper As Per **UGC Guidelines** We Are Providing A Electronic Bar Code

ZCS BASED SOFT SWITCHING TECHNIQUE FOR MODULAR INVERTER FED BY PV-ARRAY

¹PALLE VAMSHI, ²M.D.IMRAN

M.Tech (Power Electronics), Vaageswari College of Engineering Karimnagar, T.S, INDIA

Asst. Professor, Vaageswari College of Engineering Karimnagar, T.S, INDIA

ABSTRACT: A solitary stage differential-mode current-encouraged zero-current-exchanging inverter has been planned. This inverter has two modules of dc/dc converters that are associated differentially to the information source. This inverter does not require 60-Hz transformer, front-end dc/dc converter, and can help a low-voltage contribution to air conditioning yield utilizing a smaller low-turns-proportion transformer as a result of the additional voltage pick up of the topology. Primary switches of the inverter are delicate exchanged. The inverter requires a littler high-recurrence transformer due to high-recurrence exchanging, bipolar transformer current, and voltage in each exchanging cycle, and in light of the fact that the transformer sees just 50% of the info current. The measured quality of the inverter expands the extent of the topology to be utilized as a dc/dc converter, single-stage inverter, and furthermore the likelihood of stretching out the topology to both split stage and three stage.

I. INTRODUCTION

One of the single stage topologies delineated in [1] accomplishes dc/air conditioning transformation by associating the contributions of two indistinguishable dc/dc support converters in parallel with a dc source and the heap is associated over the yields of the two dc/dc converters. Instead of an ordinary buck voltage source inverter, this topology can produce a yield voltage higher than the info voltage. In any case, the topology has a non-isolated engineering, the switches work at a low exchanging recurrence, and the measure of the magnetic is substantial prompting a bigger impression for a non-isolated topology. By and large, one of the regular difficulties with the buck-support inferred topologies is the high pinnacle inductor current worry due to the sudden exchange of vitality through the inductors from source to stack amid each exchanging cycle. A solitary stage

flyback inverter topology was portrayed in [2]. It involved bidirectional flyback converters that are associated in parallel to the information voltage source and the heap is associated over the two converters. The significant favorable position of this topology over the previously mentioned topologies is the galvanic detachment gave by the high-recurrence transformers in both the flyback converters. Be that as it may, the galvanic disengagement in this topology requires an expanded impression. Despite the fact that the inverter topology has four power switches and two diodes, as it were two switches are delicate exchanged. Also, the produced sinusoidal waveform comprises of semi sinusoidal heartbeats. This topology additionally does not separate the source and the heap or matrix. A solitary stage buck-support pulse width regulation power inverter is

given in [3]. It has two buck– support choppers shaping a four switch connect and an extra two more control switches for synchronous compensation in every half cycle of the yield. The real favorable position of this topology is the galvanic separation gave by the high-recurrence transformer. In any case, this topology is reasonable for low-control applications with an announced greatest energy of 140 W.

II. SYSTEM DESCRIPTION AND OPERATION

The fundamental inverter has two individual dc/dc converter modules, as appeared in Fig. 1(a). The primaries of the two person dc/dc converters, sourced by the PV vitality source, are associated in differential mode and the yield of the proposed current-sourced inverter is the distinction in the yields of the two individual dc/dc converter modules. Every module has two essential side switches, to be specific, S1 and S2 and S3 and S4 furthermore, comparing auxiliary side switches Sr1 and Sr2 and Sr3 and Sr4, separately. The exchanging recurrence of the inverter is 100 kHz. The switches in every module are tweaked, with the goal that the individual converters create a dc-one-sided sine wave yield, with the goal that every converter just creates a unipolar voltage. The regulation of every converter is 180° out of stage with the other, so the voltage journey at the heap is boosted. That is, switch sets S1 and S2 and S3 and S4 are worked similarly however with a stage contrast of 180°. Since the heap is associated differentially over the converters, the dc-inclination showing up at either end of the heap as for ground gets wiped out and the differential dc voltage over the heap is zero. Switch sets S1– Sr1, S2– Sr2, S3–

Sr3, and S4– Sr4 are activated with corresponding heartbeats.

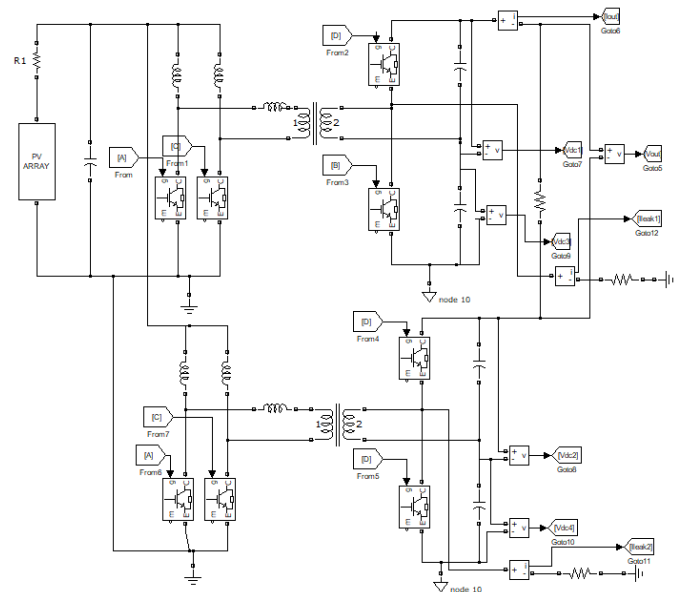

Figure 1: Simulation circuit of inverter topology

For all other exchanging designs, there is a trade of control between the essential and the optional of the person dc/dc converter module and in addition from one dc/dc converter module to another. Also, in these modes, there is a confined charging of yield capacitor of one of the dc/dc converter modules [5]. The bearing of energy stream between the person modules relies upon the time-space voltage and current waveforms. For example, for a solidarity control factor uninvolved load, amid a positive line cycle of the yield voltage (over the stack), control streams from the PV source by mean of the upper module to the base module, while amid the negative half cycle, control streams by means of base module to the upper module.

ZCT mode:For example, optional side switch Sr2 is turned ON some time recently the kill of essential side switch S1 in the upper module. The span for which Sr2 must be turned ON depends on the current through switch S1. The accompanying

modes are the extra ZCS methods of the inverter. The ZCS inverter modes expand on [4], which tends to dc/dc converter; for the differential-mode inverter delineated in this paper, there are a few operational contrasts since every dc/dc module is subjected to time-fluctuating operation.

III. CONTROL STRATEGY

To diminish the THD of the heap current of the inverter, which has a nonlinear dc pick up, a harmonic compensation control is actualized utilizing a proportional resonant (PR) controller. Moreover, the control conspire represents the progression of the essential side inductors and the optional side capacitors. Basically, and as suggested in Fig. 16, a sinusoidal voltage reference yields extra consonant parts in the real input. Thusly, while the crucial current reference is removed from the voltage circle, a zero reference is set for the higher request sounds that have substantial effect on the yield voltage. The PR controller with symphonious compensators accomplishes high pick up at the essential and symphonious frequencies, along these lines yielding a low consistent state mistake and non-sinusoidal bother in the obligation proportion, consequently yielding a low THD yield. The present summon of this voltage circle is contrasted and a differential-current criticism and went through a PR controller with symphonious compensators accomplishes high pick up at the basic and consonant frequencies, in this manner yielding a low unflinching state blunder and non-sinusoidal irritation in the obligation proportion, in this way yielding a low THD yield.

IV. SIMULATION RESULTS

To evaluate the performance of the proposed topology, a MATLAB simulation circuit has designed is shown in figure 1. Performance characteristics are given as below.

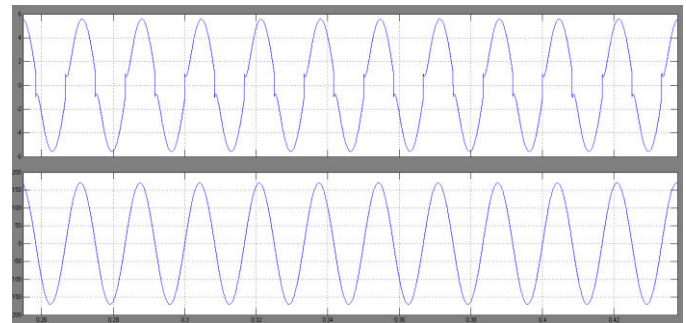

Figure 2: Output current and voltage

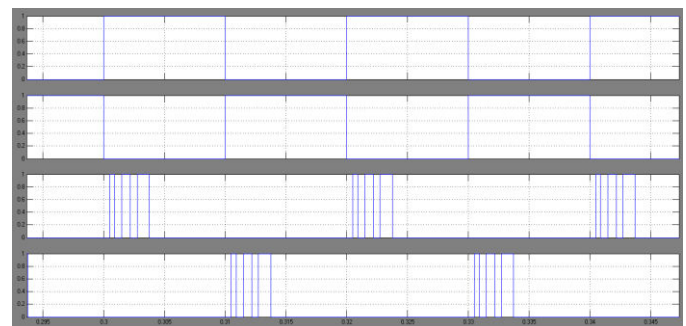

Figure 3: gate signals

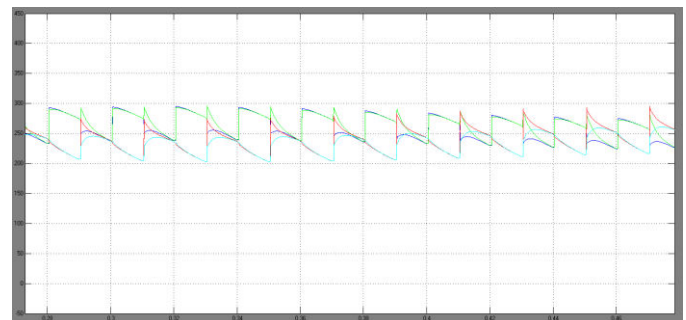

Figure 4: output capacitor voltage

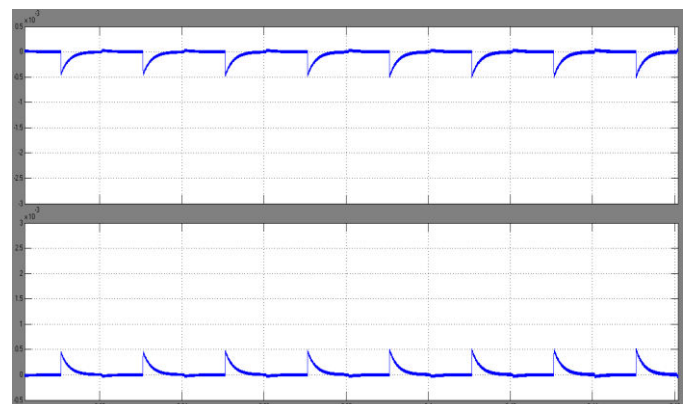

Figure 5: Inductor leakage currents

V. CONCLUSION

This paper portrays a present source high-recurrence connect inverter. It contains two dc/dc disconnected converters that are associated in a differential-mode arrangement, subsequently yielding an inverter yield. Be that as it may, the natural nonlinearity of the inverter yields consonant mutilation under open-circle condition. To moderate that issue, a consonant remuneration based control conspire is plot. The resultant shut circle controlled inverter essentially decreases the symphonious contortion of the inverter yield voltage what's more, current and yields adequate dynamic reaction. At last, work in progress at present to orchestrate an exploratory inverter.

techniques,” Ph.D. dissertation, Dept. Elect. Eng., IIT Bombay, Mumbai, India, Aug. 2004.

REFERENCES

1. R. Caceres and I. Barbi, “A boost DC-AC converter: Operation, analysis, control and experimentation,” in Proc. IEEE 21st Int. Conf. Ind. Electron., Control, Instrum., Nov. 1995, pp. 546–551.
2. S. B. Kjør and F. Blaabjerg, “A novel single-stage inverter for the AC-module with reduced low-frequency ripple penetration,” in Proc. 10th Eur. Conf. Power Electron. Appl. EPE, Toulouse, France, Sep. 2003, p. 10.
3. M. Nagao and K. Harada, “Power flow of photovoltaic system using buck-boost PWM power inverter,” in Proc. IEEE PEDS, Singapore, May 1997, pp. 144–149.
- A. K. Rathore and S. K. Mazumder, “Novel zero-current switching current-fed half-bridge isolated DC/DC converter for fuel cell based applications,” in Proc. IEEE Energy Convers. Congr. Expo., Sep. 2010, pp. 3523–3529.
4. S. Jain, “Single-stage, single-phase grid connected PV systems with fast MPPT