



International Journal for Innovative Engineering and Management Research

A Peer Reviewed Open Access International Journal

www.ijiemr.org

COPY RIGHT



ELSEVIER
SSRN

2022IJIEMR. Personal use of this material is permitted. Permission from IJIEMR must be obtained for all other uses, in any current or future media, including reprinting/republishing this material for advertising or promotional purposes, creating new collective works, for resale or redistribution to servers or lists, or reuse of any copyrighted component of this work in other works. No Reprint should be done to this paper, all copy right is authenticated to Paper Authors

IJIEMR Transactions, online available on 28th August 2022. Link

[:http://www.ijiemr.org/downloads.php?vol=Volume-11&issue=ISSUE-08](http://www.ijiemr.org/downloads.php?vol=Volume-11&issue=ISSUE-08)

DOI: 10.48047/IJIEMR/V11/ISSUE 08/28

Title **SMART TROLLEY USING RFID WITH AUTOMATATION**

Volume 11, Issue 08, Pages: 217-225

Paper Authors

Mr. K Rajendra, Mr. R Naveen Kumar, Mr. V N S R Murthy, Mr. J. Suresh, Mr. B.Narendra



USE THIS BARCODE TO ACCESS YOUR ONLINE PAPER

To Secure Your Paper As Per **UGC Guidelines** We Are Providing A Electronic Bar Code

SMART TROLLEY USING RFID WITH AUTOMATATION

Mr. K Rajendra, Assistant Professor, EEE Department, Ramachandra College of Engineering, Eluru
Mr. R Naveen Kumar, Assistant Professor, EEE Department, Ramachandra College of Engineering, Eluru
Mr. V N S R Murthy, Assistant Professor, EEE Department, Ramachandra College of Engineering, Eluru
Mr. J. Suresh, Assistant Professor, EEE Department, Ramachandra College of Engineering, Eluru
Mr. B.Narendra, Assistant Professor, EEE Department, Ramachandra College of Engineering, Eluru

Abstract:

Now a days interest in shopping malls is widely increasing among people. People get daily necessities from shopping malls. There is an emerging demand for easy and quick payment of bills in shopping malls. Shoppers are frustrated at locating the items on the shopping list when shopping in shopping malls and when no assistance is available in shopping. To eliminate these problems, each product in the shopping mall will be provided with a RFID tag, to identify its type. Each shopping cart is implemented with a smart Identification Device (PID) that contains a microcontroller, an LCD, RFID reader and a ZIGBEE transmitter. RFID reader will read the purchasing product information on the shopping cart and the information about the product is displayed on LCD which is interfaced to the microcontroller. At the billing counter, the total bill will be transferred to PC at the counter side by using ZIGBEE module. In this paper, AT89S52 microcontroller is attached to an RFID reader and a barcode reader. As the user puts items in the trolley the reader on the trolley reads the tag and sends a signal to the controller. The controller then stores it in the memory and compares it with product ID. If it matches, it shows the name of item on LCD and also total amount of items purchased. Once the shopping is finished, the customer will press a button on the trolley send the total amount spent on the products to the billing counter section using ZIGBEE wireless communication module. In this project, there is a chance to revert back the product according to our need and budget. Once you take back product from the trolley, the same card will be again read by the RFID reader, then the controller will deduct the same amount associated to that product, from the net bill amount. The bill amount will be received by the ZIGBEE receiver and sent to the PC to display in the Hyper Terminal.

1. INTRODUCTION

The word smart is trending lately in the field of IoT. Every object around us is being made smart so as to make our work easier. With the increase in internet technology, food items are available at our door steps whenever needed. But the experience of going to a mall and

shopping the things all by yourself has its own advantages and disadvantages as well. The advantage is that we can carefully select the best product according to our choice and judge the product by seeing, touching and feeling it. The major drawback of this is standing in stretched out

line of customers for paying off the bill. The brought forward smart shopping structure avoids this drawback and also has additional features for the convenience of the consumer. In this smart shopping cart system, real-time updates on the inventories are also provided in the store management section.

The shopping trolleys currently being used all over the world are simple carrying basket with wheels as an added facility. These trolleys do not respond in any ways to the user and just serve the purpose of carrying the items to be bought by the person. We, by our project on

Remote Controlled Smart Shopping Cart, are thinking of ways to make this a more advanced system. We have in our project added a feature through which the person gets the bill amount of his/her products or items kept in the cart on the cart itself. The product uses a RFID system which is well known for scanning multiple items at a given time. The RFID reader will be mounted on each cart and as soon as the customer starts keeping items in the cart, the RFID reader starts scanning the tags on each

item and displays the total bill amount on the LCD which is attached along with the RFID reader upon the cart. Thus, our Smart Trolley provides a Real Time Response to the people using it. Another enhancement we have brought into the shopping cart is the Remote controlled movement of the whole cart with variable speed control measurements. This will be done by using Induction motors along with VFDs or by using Servo motors in the cart. The cart measures the weight kept inside it and accordingly varies the speed of the cart. Now, the cart has the technology of remote movement, which means the customer wouldn't even be touching

the cart while taking it around inside the mall! This is done by the use of Accelerometer which moves the cart according to which the user moves his/her hand. A glove with the Remote control system would be provided to the customer. All these systems combined, make our project "Remote Controlled Smart Shopping Trolley with Automated Billing with the use of RFID", which is a small step towards making a Smarter India!

2. Micro controller

Microcontroller is a general purpose device, which integrates a number of the components of a microprocessor system on to single chip. It has inbuilt CPU, memory and peripherals to make it as a mini computer. A microcontroller combines on to the same microchip:

The CPU core

- Memory (both ROM and RAM)
- 2. Some parallel digital i/o

Microcontrollers will combine other devices such as:

1. A timer module to allow the microcontroller to perform tasks for certain time periods.
2. A serial I/O port to allow data to flow between the controller and other devices such as a PIC or another microcontroller.
3. An ADC to allow the microcontroller to accept analogue input data for processing.



microcontrollers have been developed around specifically designed CPU cores, for example the microchip PIC range of microcontrollers. AT89C52 is the 40 pins, 8 bit Microcontroller manufactured by Atmel group. It is the flash type reprogrammable memory. Advantage of this flash memory is we can erase the program with in few minutes. It has 4kb on chip ROM and 128 bytes internal RAM and 32 I/O pin as arranged as port 0

to port 3 each has 8 bit bin .Port 0 contain 8 data line(D0-D7) as well as low order address line(A0-A7).

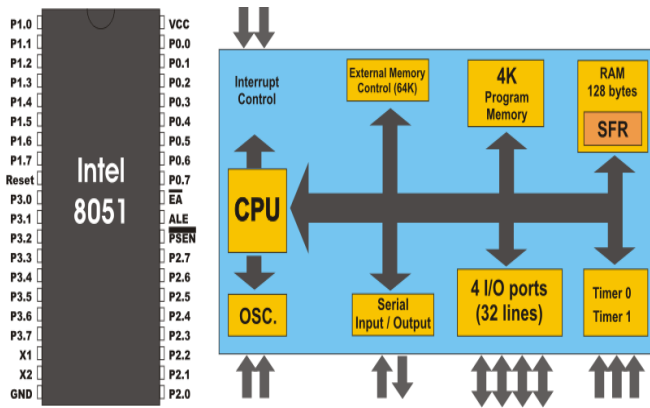

Figure 2.1: Architecture of 8052 Microcontroller

2.2 Oscillator and Clock circuits:

The heart of the 8052 is the circuitry that generates the clock pulse by which all internal operations are synchronized. Pins XTAL1 and XTAL2 are provided for connecting a resonant network to form an oscillator. Typically, a quartz crystal and capacitors are employed, as shown in Figure 3.7 the crystal frequency is the basic internal clock frequency of the microcontroller. The manufacturers make available 8052 designs that can run at specified maximum and minimum frequencies, typically 1 megahertz to 24 megahertz. Minimum frequencies imply that some internal memories are dynamic and must always operate above a minimum frequency or data will be lost. Serial data communication needs often state the frequency of the oscillator because of the requirement that internal counters must divide the basic clock frequency is not divisible without a

remainder, and then the resulting communication frequency is not standard.

3. POWER SUPPLY

The power supply circuits built using filters, rectifiers, and then voltage regulators. Starting with an ac voltage, a steady dc voltage is obtained by rectifying the ac voltage, then filtering to a dc level, and finally, regulating to obtain a desired fixed dc voltage. The regulation is usually obtained from an IC voltage regulator unit, which takes a dc voltage and provides a somewhat lower dc voltage, which remains the same even if the input dc voltage varies, or the output load connected to the dc voltage changes

4. RFID

Full form of RFID is “Radio Frequency Identification”. Wireless communication is used between RFID tags and RFID Reader. Reader does not require line of sight communication with tags. It means that Reader detects the RFID tag even if there is some object between Card and Reader. Thus it is a non-contact type of reader. The Radio frequency used in our reader is 125 kHz which is a Low Frequency (LF). RFID reader interfacing with microcontroller is done using serial port. RFID reader will communicate with microcontroller using serial communication.

When RFID tag comes in the range of Reader module, then RFID reader detects RFID card. And at that time RFID reader sends out a series of alphanumeric unique codes on the serial port. So



while adding the employees/student card number in the program memory. First we need to store this

series of alphanumeric code into program memory and later on this unique series of codes will be compared with the incoming card number. RFID card reader module requires 9 volt power supply and output is given on DB9 connector port.

RFID CARD (PASSIVE TAG):

There are two main types of RFID cards, Passive and Active. In this project we have used Passive RFID tags. As given in introduction, we can use normal RFID cards which are of the size of credit card. These are rectangular in shape and white in color and can be attached with the ID-card. Or even we can use RFID tags which can be attached with keychain



Figure of RFID card

5.LCD Display

The LCD display consists of two lines, 20 characters per line that is interfaced with the

For operating this project first user has to insert the card numbers into the microcontroller memory. It can be done by company authority person or college administration person while issuing the card. Whenever a new student joins or new employee is recruited in an organization/company at that time, card will be issued. And same entry will

PIC16F73.The protocol (handshaking) for the display is as shown in Fig. The display contains two internal byte-wide registers, one for commands (RS=0) and the second for characters to be displayed (RS=1). It also contains a user-programmed RAM area (the character RAM) that can be programmed to generate any desired character that can be formed using a dot matrix. To distinguish between these two data areas, the hex command byte 80 will be used to signify that the display RAM address 00h will be chosen Port1 is used to furnish the command or data type, and ports 3.2 to 3.4 furnish register select and read/write levels.

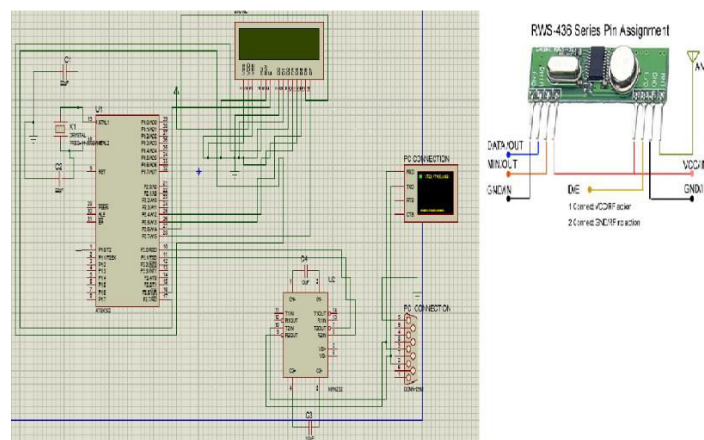

5.1.1 Figure LCD

6.Circuit diagram of Receiver:

be made in The microcontroller program memory.



In the current project, these numbers They are stored in the microcontroller's program memory. Which means while burning the program into memory, we need to add these card numbers into the program. Then this card will be issued to the respective person. When a student or employee has lost his/her card. Then in such situation he/she has to report this incident to the administration person. Then admin person can remove the card number

from microcontroller memory. Also when any employee or student leave the office and they forget to return the card then at time also authority person will remove the card information from microcontroller memory. So in case of lost card or person left the company without returning the card and if these cards are shown to RFID reader then buzzer will be turned on.

Lets take an example that any outside/unauthorized person get a RFID card. And these cards does not have entry in our system. Or if existing employee manages to get a RFID card, and if he/she shows card, then microcontroller will check and find that this card is not stored in the memory. It means card number is not found in microcontroller memory then buzzer is turned on.

We have provided total 12 cards with this system for demonstration purpose. Out of these, 10 cards are valid cards and 2 invalid cards are provided. An invalid card means those cards which do not have information stored in microcontroller program memory.

RF communication:

RFID attendance system has RF Transmitter and RF Receiver. The data retrieved from the RFID Reader is displayed on LCD and transmitted through RF Transmitter and received at the RF Receiver which is interfaced to the computer and displayed on LCD..

Computer Interfacing with RFID based attendance system:

We have provided PC interfacing to this project, so that attendance of employees can be seen on computer. To view the attendance first administrative person or the user operating this project has to press the Attendance key, then LCD display will display attendance of all students/employees.

LCD will display card number 1, login time then card number 2, login time and so on... It will show attendance of those people who have logged in on that particular day. LCD display is helpful if PC interfacing is not available. Which means Computer is not near system. In PC interfacing, Data is sent to computer as soon as it is shown on LCD display. Various software are available to view data received on serial port. On computer we can use hyper terminal software or we can use terminal software to view the data received on computer. Later user can copy this data into another file or he/she can directly take the print out. PC interfacing will be useful when the data is very large or when employee number is very large. At that time attendance monitoring on LCD becomes very time consuming and is not easy. However, data for all employees can be viewed on computer at a faster rate and very easily.

7. RESULT :

1. In the beginning, when the kit is switched on by providing the power supply to the kit, the below images are seen which show “WELCOME” on the LCD screen of the device.



2. Now the Trolley is ready to scan the products.



3. When an RFID tag is scanned by the RFID reader, the images as shown below are displayed along with the details of the name of the product, cost of the product .

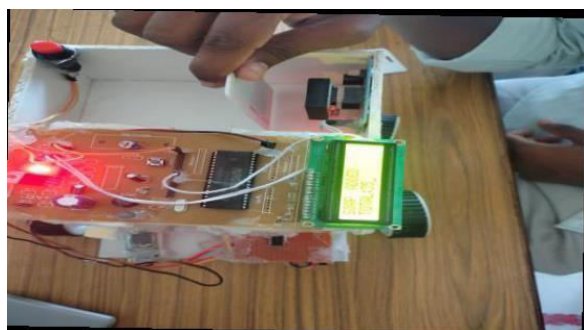

When the next it was added it will be displayed as the above fig.

After completing the shopping the press the completed button then the it will be displayed below



The total billing amount displayed and the no. of item is scanned .



8. CONCLUSION :

In Smart Trolley System, now there is no need for the customers to wait in the queue and wait for his/her turn for the scanning of the product items.

A secure smart shopping system utilizing RFID technology is employed in enhancing shopping experiences and security issues. The smart shelves are able to monitor the items on the shelves by reading the RFID signals from the tags. The smart carts are able to read and retrieve information of the items inside the carts and finally, the checkout points can validate the purchase made by a customer. So, supermarkets or hypermarkets use this concept as their business strategy to attract more number of customers

9. REFERENCE

[1] F. Xia, L. T. Yang, L. Wang, and A. Vinel, "Internet of things," *International Journal of Communication Systems*, vol. 25, no. 9, p. 1101, 2012.

[2] P. Castillejo, J.-F. Martinez, J. Rodriguez-Molina, and A. Cuerva, "Integration of wearable devices in a wireless sensor network for an e-health application," *IEEE Wireless Communications*, vol. 20, no. 4, pp. 38–49, 2013.

"Sliding mode Control of a buck Converter based inverter operating with fixed frequency"

in *International Journal of Scientific Research in Computer Science Applications and Management Studies (IJSRCSAMS)* Vol. 3 Issue 6, November – 2014. ISSN: 2319 – 1953.

[3] "Sliding Model Control of wide Input Output DC DC Boost Converter" in *International Journal of Scientific and Engineering Research* Vol 4, Issue 11, November 2013. ISSN: 2229 – 5518.

[4] "Analysis of Coupled Inductor type Power DC-DC Boost Converter with synchronized PWM Control" in *International Journal of Engineering Research & Technology (IJERT)* Vol. 2 Issue 3, March – 2013. ISSN: 2278 – 0181