



International Journal for Innovative Engineering and Management Research

A Peer Reviewed Open Access International Journal

www.ijiemr.org

COPY RIGHT

2017 IJIEMR. Personal use of this material is permitted. Permission from IJIEMR must be obtained for all other uses, in any current or future media, including reprinting/republishing this material for advertising or promotional purposes, creating new collective works, for resale or redistribution to servers or lists, or reuse of any copyrighted component of this work in other works. No Reprint should be done to this paper, all copy right is authenticated to Paper Authors

IJIEMR Transactions, online available on 24th Oct 2017. Link

[:http://www.ijiemr.org/downloads.php?vol=Volume-6&issue=ISSUE-9](http://www.ijiemr.org/downloads.php?vol=Volume-6&issue=ISSUE-9)

Title: **THREE-PHASE STATCOM CONTROLLER USING D-Q FRAME THEORY BASED THREE-PHASE SEIG FOR DIFFERENT LOAD CONDITIONS**

Volume 06, Issue 09, Pages: 252–260.

Paper Authors

BABUSAB NAVEEN, P.SRIDHAR, LINGA SWAMY

Institute of Aeronautical Engineering College, Dundigal;Ranga Reddy (DT); Telangana, India



USE THIS BARCODE TO ACCESS YOUR ONLINE PAPER

To Secure Your Paper As Per **UGC Guidelines** We Are Providing A Electronic Bar Code

THREE-PHASE STATCOM CONTROLLER USING D-Q FRAME THEORY BASED THREE-PHASE SEIG FOR DIFFERENT LOAD CONDITIONS

¹BABUSAB NAVEEN, ²P.SRIDHAR, ³LINGA SWAMY

¹M-tech Student Scholar, Department of E.E.E, Institute of Aeronautical Engineering College, Dundigal; Ranga Reddy (DT); Telangana, India.

²Assistant Professor & Head of the department, Department of E.E.E, Institute of Aeronautical Engineering College, Dundigal; Ranga Reddy (DT); Telangana, India.

³Assistant Professor, Department of E.E.E, Institute of Aeronautical Engineering College, Dundigal; Ranga Reddy (Dt); Telangana, India.

¹naveen.babusab@gmail.com, ²sridharp35@gmail.com, ³Kandadilingareddy@gmail.com

ABSTRACT-This project presents an analysis of the three-phase self excited induction generator (SEIG) with static compensator (STATCOM) as a voltage regulator. Current controlled voltage source inverter (CC-VSI) is used as STATCOM, which provides fast dynamic response to maintain constant voltage at SEIG terminals during severe load perturbations and acts as a source and sink of reactive power. The performance equations are derived using d-q variable in stationary reference frame to develop a mathematical model of SEIG-STATCOM system feeding unbalanced loads. Transient analysis of the SEIG STATCOM system is carried out for voltage build-up; switching in STATCOM, application and removal of balanced/unbalanced resistive/reactive loads. The STATCOM regulates the SEIG terminal voltage through reactive power compensation and also suppresses the harmonics injected by consumer loads. A single-phase synchronous D-Q frame theory-based control algorithm is used to generate gating pulses to the three-phase STATCOM. The proposed concept can be implemented with three-phase loads also by using MATLAB/SIMULINK software.

KEYWORDS—self excited induction generator (SEIG); single-phase synchronous D-Q frame theory; static synchronous compensator (STATCOM)

I INTRODUCTION

In remote areas, plenty of non-conventional energy sources are available. These non-conventional energy sources are used as prime input for the generating systems. Externally driven induction machine operates as a self-excited induction generator (SEIG) with its excitation requirements being met by a capacitor bank connected across its terminals.

The SEIG has advantages like simplicity, maintenance free, absence of DC, brushless etc. as compare to the conventional synchronous generator. Self-excitation phenomenon in induction machines although known for more than a half century. This induction generator is self excited by a suitable capacitor banks across the terminals.

This phenomenon is known as capacitor self excitation and the induction generator is called a “SEIG” [2]. A major disadvantage of SEIG is its poor voltage regulation requires a variable capacitance bank to maintain constant terminal voltage under varying loads. Attempts have been made to maintain constant terminal voltage by using passive elements [5], short – shunt [6] and long -shunt method for a three-phase SEIG [7]. Fixed capacitor and thyristor-controlled inductor known as static Var compensator (SVC) [10] for voltage compensation. By the invention of solid-state self-commutating devices, it is possible to make a static, noiseless voltage regulator, which can provide continuously variable reactive power to the SEIG with varying load to keep terminal voltage constant. This system called STATCOM has specific benefits compared to SVC [12], Schauder and Mehta [13] have derived governing equations of STATCOM to determine the response of the STATCOM. In this paper, the single phase linear and non-linear load share connected to the three-phase SEIG which cause unbalance current and draws non-sinusoidal current due to non-linearity of load which injects harmonics into the system. The STATCOM is introduced to eliminate the harmonics, provides load balancing and supplies the reactive power and feeding single-phase loads using a three-phase SEIG without de-rating the machine. The transient analysis of the SEIG-STATCOM system under balanced/unbalanced single-phase linear and non-linear loads and simulated results show that the SEIG-STATCOM system behaves an ideal supply under these unbalanced loads.

II SELF EXCITED INDUCTION GENERATOR (SEIG)

A) Induction generator:

The induction generators offer advantages over synchronous machines, resulting in a simplified installation with economy in first cost and in operating and maintenance expenses. The attractive feature of the induction generator is simplicity of operation.

B) Process of self excitation:

When an induction machine is driven at a speed greater than the synchronous speed then there will be negative slip. By means of an external prime mover, the direction of induced torque is reversed and it starts working as an induction generator. When the slip is negative then the induction machine draws a current, which lags the voltage by more than 90. This means that real power flows out of the machine but the machine needs the reactive power. To build up voltage across the generator terminals, excitations must be provided by two modes (i.e., grid connected and isolated mode). In case of a grid-connected mode, the induction generator can draw reactive power either from the grid but it will place a burden on the grid for an isolated mode, there must be a suitable capacitor bank connected across the generator terminals. This phenomenon is known as capacitor self-excitation and the induction generator is called a “SEIG.”

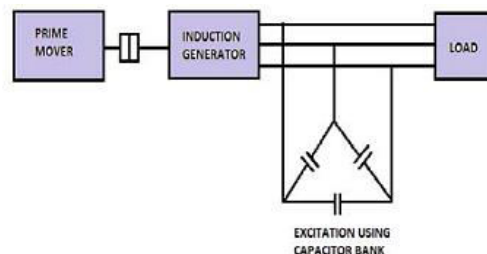

Fig 1.self excitation of induction generator

III STATIC SYNCHRONOUS COMPENSATOR (STATCOM)

The static synchronous compensator is a shunt-connected reactive power compensation device which provides voltage support by generating or absorbing reactive power at the point of common coupling without the need of large external reactors or capacitor banks.

a) Modeling of control scheme of STATCOM:

The single-phase synchronous D-Q frame theory-based control algorithm for the three-phase STATCOM is shown in figure 3.2. A single-phase synchronous D-Q frame theory-based control has been used to generate switching pulses to the three-phase STATCOM. In case of a three-phase system, initially, the three-phase voltages or currents (in abc frame) are transformed to a stationary frame ($\alpha - \beta$) and then to synchronously rotating D-Q frame. Therefore, to transform a signal into a stationary $\alpha - \beta$ frame, at least two phases are needed. The original signal represents the component of α -axis and 90h lag signal is the β -axis component of stationary reference frame.

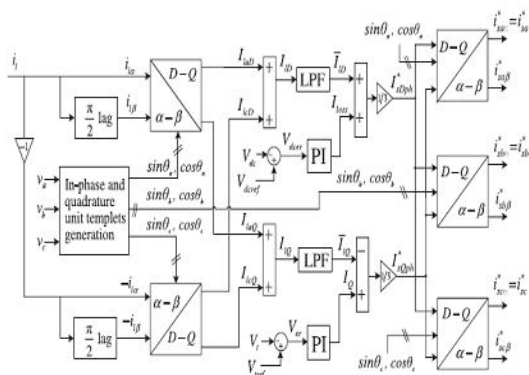

Fig 2. Block diagram of D-Q frame theory

The PCC voltages (v_a, v_b, v_c), source currents (i_{sa}, i_{sb}, i_{sc}), load current (i_l), and dc bus voltage (V_{dc}) are sensed and used as feedback

signals. Considering PCC voltages as balanced and sinusoidal, the amplitude of the PCC voltage or system voltage is estimated as

$$V_t = \sqrt{\frac{2}{3}(V_a^2 + V_b^2 + V_c^2)} \quad (1)$$

The transformation of voltages and currents of one particular phase into a stationary $\alpha - \beta$ frame, then the PCC voltages and load current in stationary $\alpha - \beta$ frame are represented as

$$\begin{aligned} V_{a\alpha}(t) &= V_a(t) \\ V_{b\alpha}(t) &= V_b(t) \end{aligned} \quad (2)$$

$$\begin{aligned} V_{a\beta}(t) &= V_a(t - T/4) \\ V_{b\beta}(t) &= V_b(t - T/4) \\ V_{c\beta}(t) &= V_c(t - T/4) \end{aligned} \quad (3)$$

$$\begin{aligned} i_{1\alpha}(t) &= i_1(t) \\ i_{1\beta}(t) &= i_1(t - T/4) \end{aligned} \quad (4)$$

Now consider a synchronously rotating D-Q frame for phase "a" which is rotating in the same direction as $v_a(t)$, Therefore, the D-axis and Q-axis components of the load current in phase "a" are estimated as

$$\begin{bmatrix} I_{1\alpha} \\ I_{1\beta} \end{bmatrix} = \begin{bmatrix} \cos\theta_a & \sin\theta_a \\ -\sin\theta_a & \cos\theta_a \end{bmatrix} \begin{bmatrix} i_{1\alpha} \\ i_{1\beta} \end{bmatrix} \quad (5)$$

Where $\cos\theta_a$ and $\sin\theta_a$ are estimated using $v_{a\alpha}$ and $v_{a\beta}$ as follows:

$$\begin{bmatrix} \cos\theta_a \\ \sin\theta_a \end{bmatrix} = \frac{1}{\sqrt{(V_{a\alpha}^2 + V_{a\beta}^2)}} \begin{bmatrix} V_{a\alpha} \\ V_{a\beta} \end{bmatrix} \quad (6)$$

where θ can be estimated using a single-phase PLL structure based on second order generalized integrator. Using the PLL structure the phase angle, amplitude and

frequency of the utility are detected. The figure 3 shows the general structure of PLL.

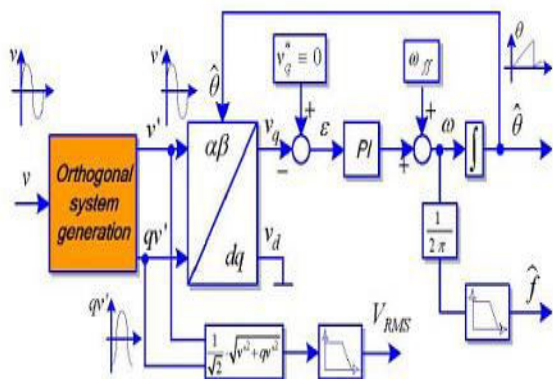

Fig 3 General structure of PLL

I_{iaD} represents the active power component of the load current as the signals belong to the same axis are multiplied and added to estimate the D-axis component, whereas I_{iaQ} represents the reactive power component of the load current as the orthogonal signals are multiplied and added to derive the Q axis component. Similarly, the D-axis and Q-axis components of the load current in phase “c” are estimated as

$$\begin{bmatrix} I_{icD} \\ I_{icQ} \end{bmatrix} = \begin{bmatrix} \cos\theta_c & \sin\theta_c \\ -\sin\theta_c & \cos\theta_c \end{bmatrix} \begin{bmatrix} -i_{ia} \\ i_{ib} \end{bmatrix} \quad (7)$$

The negative sign of currents in (7) indicates that the load current in phase “c” is equal to phase “a” but 180° out of phase. As the single-phase load is connected across the phases “a” and “c,” D-axis and Q-axis components for phase “b” are not estimated. The D-axis components of the load current is given as

$$I_{iD} = I_{iaD} + I_{icD} \quad (8)$$

Similarly, an equivalent Q-axis current component of total load on the system is estimated as

$$I_{iQ} = I_{iaQ} + I_{icQ} \quad (9)$$

The equivalent D-axis and Q-axis current components of total load are decomposed into two parts namely fundamental and oscillatory parts as

$$I_{iD} = I_{iD} + I_{iD} \quad (10)$$

$$I_{iQ} = I_{iQ} + I_{iQ} \quad (11)$$

The reason for the existence of the oscillatory part is due to the nonlinear and single-phase nature of connected loads in the system. Even if the connected loads are linear in nature, the D and Q components estimated in (8) and (9) would still contain oscillatory parts due to the unbalance caused by single-phase loads. To ensure the power quality, the reference D-axis and Q-axis components of source currents must be free from these oscillatory components. by using low-pass filter the fundamental components are extracted. To maintain the dc-bus capacitor voltage of the STATCOM at a reference value, it is sensed and compared with the reference value and then they obtained voltage error is processed through a PI controller. The dc-bus voltage error of the STATCOM V_{dcer} at kth sampling instant is expressed as

$$V_{dcer}(k) = V_{dcref}(k) - V_{dc}(k) \quad (12)$$

Where $V_{dcref}(k)$ and $V_{dc}(k)$ are the reference and sensed dc bus voltages of the STATCOM at kth sampling instant, respectively. In the present investigation, the dc-bus voltage reference is set to 400 V. The output of the PI controller for maintaining a constant dc bus voltage of the STATCOM at kth sampling instant is expressed as

$$\begin{aligned} I_{loss}(k) = & I_{loss}(k-1) + K_{pd}\{V_{dcer}(k) \\ & + V_{dcer}(k-1)\} \\ & + K_{id}V_{dcer}(k) \end{aligned}$$

Where I_{loss} is the active power component of the current (or D axis current component) that must be supplied to meet the losses in the STATCOM. K_{pd} and K_{id} are the proportional and integral gain constants of the dc-bus voltage PI controller, respectively. The source should supply the power loss component of the current (I_{loss}) along with the filtered equivalent D-axis current component of the single-phase load estimated in (3.11). In order to ensure balanced and sinusoidal source currents, the D-axis component of source currents after compensation must be equal for all the phases and it should not contain any ripple. Therefore, I_{ID} is added to I_{loss} and distributed among all the phases equally to obtain the D-axis component of the reference source current in each phase which can be expressed as

$$I_{sDph}^* = \frac{\overline{I_{ID}} + I_{loss}}{3} \quad (3.14)$$

I_{sDph}^* also indicates the active power component of the current that should be supplied by the source after compensation. For regulating the system voltage (i.e., PCC voltage), the STATCOM has to inject the reactive power component of the current to meet the reactive power demands of both the load and SEIG. The amount of the reactive power component of the current to be injected by the STATCOM is estimated by an ac voltage PI controller. The amplitude of the PCC voltage computed in (3.1) is compared with the reference voltage. The PCC voltage error $V_{er}(k)$ at k th sampling instant is given as

$$V_{er}(k) = V_{tref}(k) - V_t(k) \quad (15)$$

Where V_{tref} is the amplitude of the reference PCC voltage and $V_t(k)$ is the

amplitude of sensed three-phase ac voltages at the PCC terminals, at k th instant. The reference voltage is selected to maintain the PCC line voltage at 220 V. The output of the PI controller for maintaining the PCC voltage at the reference value in k th sampling instant is expressed as

$$I_Q(k) = I_Q(k-1) + K_{pa}\{V_{er}(k) + V_{er}(k-1)\} + K_{ia}V_{er}(k) \quad (16)$$

Where K_{pa} and K_{ia} are the proportional and integral gain constants of the PI controller, $V_{er}(k)$ and $V_{er}(k-1)$ are the voltage errors at k th and $(k-1)$ th instants, respectively. $I_Q(k)$ is the equivalent Q-axis component (or reactive power component) of the current to be supplied by the STATCOM to meet the reactive power requirements of both the load and SEIG, thereby it maintains the PCC voltage at the reference value. The per phase Q-axis component of the reference source current required to regulate the system voltage is defined as

$$I_{sQph}^* = \frac{I_Q - \overline{I_Q}}{3} \quad (17)$$

I_{sQph}^* indicates the magnitude of the reactive power component of the current that should be supplied to each phase of the source (i.e., SEIG) to achieve the reference terminal voltage. The value of I_{sQph}^* can be either positive or negative based on loading conditions. Using the D-axis and Q axis components of currents derived in (3.15) and (3.18), the phase “a,” α -axis and β -axis components of the reference source current can be estimated as

$$\begin{bmatrix} i_{sa\alpha}^* \\ i_{sa\beta}^* \end{bmatrix} = \begin{bmatrix} \cos\theta_a & \sin\theta_a \\ -\sin\theta_a & \cos\theta_a \end{bmatrix} \begin{bmatrix} i_{sDph}^* \\ i_{sQph}^* \end{bmatrix} \quad (18)$$

In the above matrix, the α -axis current represents the reference source current of actual phase “a,” and the β -axis current represents the current that is at $\pi/2$ phase lag which belongs to the fictitious phase. Therefore, one can have

$$I_{sa}^* = I_{SDph}^* \cos\theta_a - I_{SQph}^* \sin\theta_a \quad (19)$$

Similarly, reference source currents for phases “b” and “c” are estimated as

$$I_{sb}^* = I_{SDph}^* \cos\theta_b - I_{SQph}^* \sin\theta_b \quad (20)$$

$$I_{sc}^* = I_{SDph}^* \cos\theta_c - I_{SQph}^* \sin\theta_c \quad (21)$$

Three-phase reference source currents (i_{sa}^* , i_{sb}^* , and i_{sc}^*) are compared with the sensed source currents (i_{sa} , i_{sb} , and i_{sc}) and the current errors are computed as

$$i_{aerr} = i_{sa}^* - i_{sa} \quad (22a)$$

$$i_{berr} = i_{sb}^* - i_{sb} \quad (22b)$$

$$i_{cerr} = i_{sc}^* - i_{sc} \quad (22c)$$

These current error signals are fed to the current-controlled PWM pulse generator for switching the IGBTs of the STATCOM. Thus, the generated PWM pulses are applied to the STATCOM to achieve sinusoidal and balanced source currents along with desired voltage regulation

IV SYSTEM CONFIGURATION AND PRINCIPLE OF OPERATION

The schematic block diagram of SEIG with excitation capacitor, STATCOM, load and voltage reference based control scheme is shown in Figure 3.4. The system consists of an SEIG driven by renewable energy-based prime mover. The single-phase consumer loads are connected across “a” and “c” phases of the SEIG. The STATCOM is connected at point of common coupling (PCC). The D-Q frame control algorithm can be modulated for

generating switching pulses to the STATCOM. The out-coming signals from the SEIG are the three-phase AC voltages.

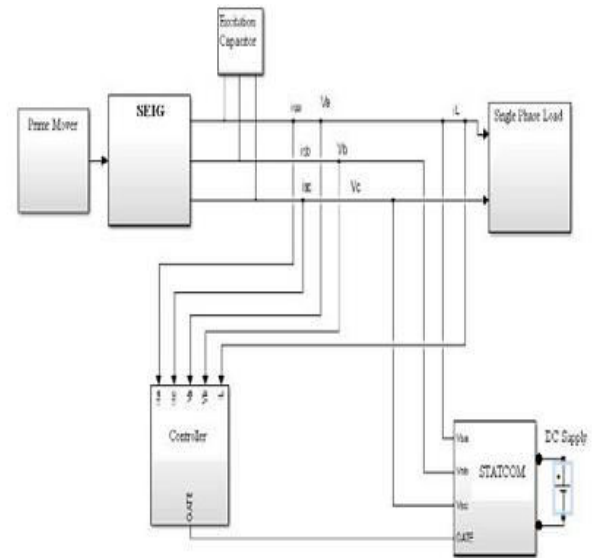

Fig 4 block diagram of SEIG-STATCOM model

The STATCOM is employed to compensate the unbalanced currents caused by single-phase loads that are connected across the two terminals of the three-phase SEIG. Therefore, the SEIG is capable of feeding single-phase loads up to its rated power. The STATCOM acts as a source of lagging or leading current to maintain the constant terminal voltage with variation in load. Moreover, the STATCOM suppresses harmonics injected by nonlinear loads and provides load balancing while feeding single-phase loads. The STATCOM consists of a two-level, three-phase IGBT based current controlled voltage source inverter and DC bus capacitor. For simulation a 3.7-kW, 230-V, 50-Hz, Y-connected induction generator has been used to investigate the performance while feeding single-phase loads. A Δ -connected 4-kVAR capacitor bank is connected across the

induction generator terminals to provide self-excitation and a induction motor having 3.7-kW, 415-V, 50-Hz, Y-connected is used to drive the SEIG. A three-phase two-level IGBT based VSI has been used as the STATCOM. The STATCOM is connected across the PCC through filter inductors. Both linear and nonlinear loads are considered for testing the system. A single-phase uncontrolled diode bridge rectifier feeding a series R-L load is used as a nonlinear load.

V MATLAB/SIMULINK MODEL

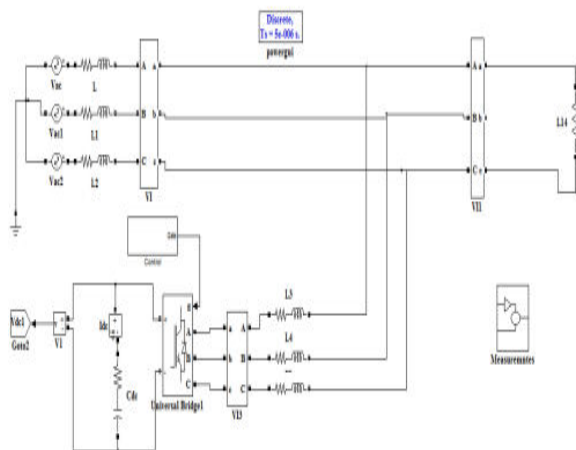

Fig 5 Matlab/simulation circuit of SEIG-STATCOM model

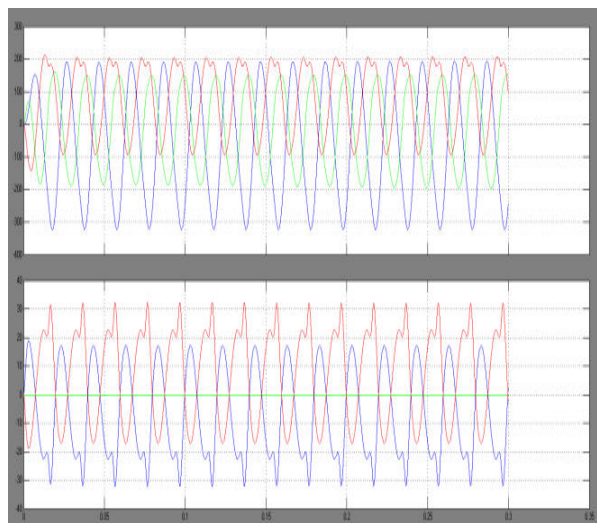

Fig 6 simulation wave form of voltage and current without statcom

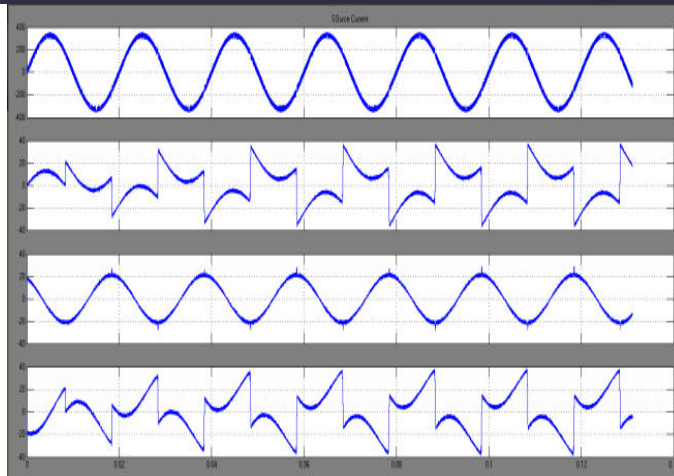

Fig 7 simulation wave form of source voltage, source current, load current without Statcom

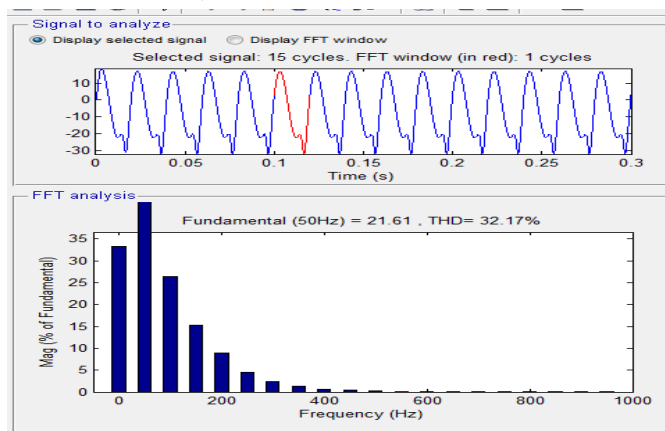

Fig 8 FFT analysis of source current waveform without STATCOM

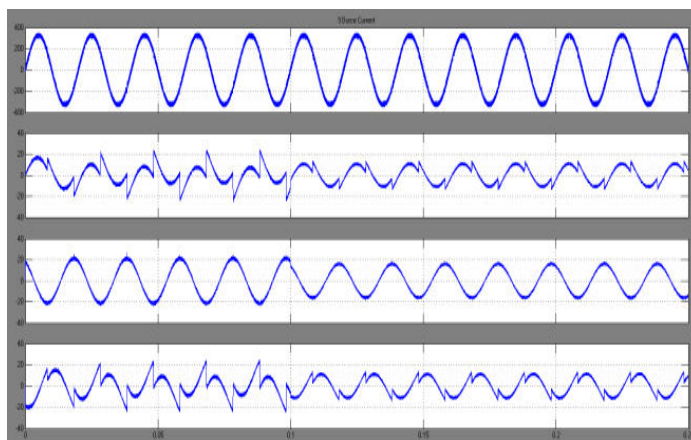

Fig 9 simulation wave form of wind SEIG source voltage, source current, compensation current and load current with single-phase loads.

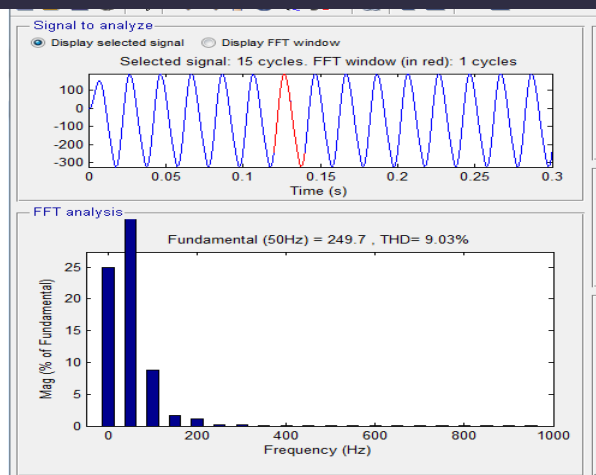

Fig 10 FFT analysis of source current waveform with STATCOM

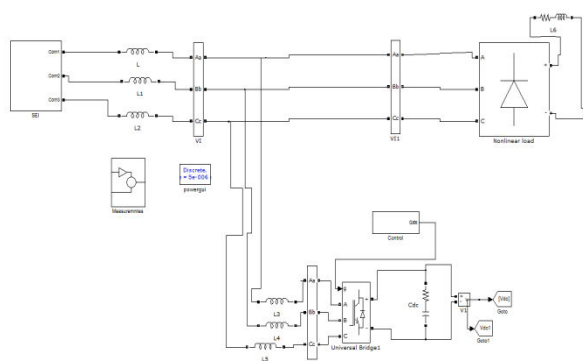

Fig 11 Matlab/simulation circuit of SEIG-STATCOM model with three-phase loads

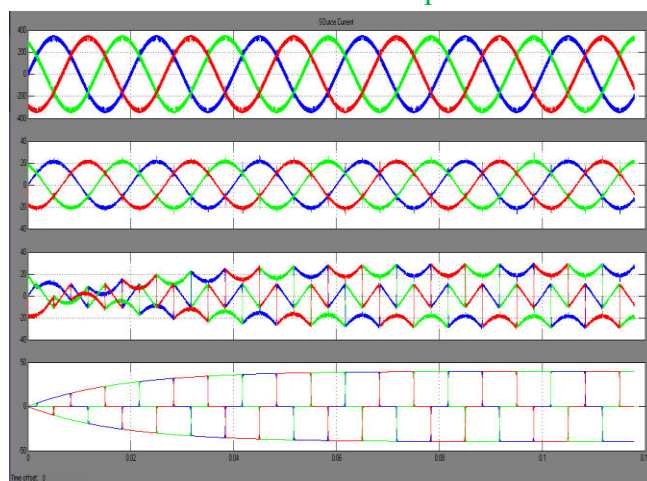

Fig 12 simulation wave form of wind SEIG source voltage, source current, compensation current and load current with three-phase loads.

VI CONCLUSION

The proposed method of feeding single-phase loads from a three-phase SEIG with STATCOM combination has been tested, and it has been proved that the SEIG is able to feed single-phase loads up to its rated capacity. D-Q frame theory based PI controller of a three-phase STATCOM has been proposed, discussed, and experimentally implemented for current balancing of the SEIG system. Model of three phase SEIG-STATCOM is capable of simulating its performance while feeding single-phase loads under transient conditions. From the simulated results, it is found that SEIG terminal voltage remains constant and sinusoidal feeding the three-phase or single-phase rectifiers with R and R-L loads. When single-phase rectifier load is connected, STATCOM currents balance these unbalance load currents and generator currents and voltage remain constant and thus STATCOM acts as load balancer. Rectifier based non-linear load generates the harmonics, which is also eliminated by STATCOM. Therefore, it is concluded that STATCOM acts as voltage regulator, load balancer and also harmonic eliminator.

REFERENCES

- [1] Bhim Singh, Fellow, IEEE, S. S. Murthy, Life Fellow, IEEE, and Raja Sekhara Reddy Chilipi, "STATCOM-Based Controller for a Three-Phase SEIG Feeding Single-Phase Loads", IEEE transactions on energy conversion, vol. 29, no. 2, June 2014.
- [2] C. Bansal, Senior Member, IEEE, "Three-phase self-excited induction generator: An overview," IEEE

- transactions on energy conversion, vol. 20, no. 2, June 2005.
- [3] Dhikra Chermiti, Adel Khedher, "A New Method Voltage and Frequency Regulation of Self-Excited " wseas transactions on environment and development Induction Generator Operating in Stand Alone
- [4] G. Dastagir and L. A. C. Lopes, "Voltage and frequency regulation of a stand-alone self-excited induction generator," in Proc. IEEE Electr. Power Conf., 2007, pp. 502–506.
- [5] H. Rai, A. Tandan, S. Murthy, B. Singh, and B. Singh, "Voltage regulation of self excited induction generator using passive elements," in Proc. IEEE Int. spp. 240– 245.
- [6] L. Shridhar, B. Singh, and C. Jha, "Transient performance of the self regulated short shunt self excited induction generator," IEEE Trans. EnergyConvers., vol. 10, no. 2, pp. 261–267, Jun. 1995.
- [7] E. Bim, J. Szajner, and Y. Burian, "Voltage compensation of an induction generator with longshunt connection," IEEE Trans. Energy Convers., vol. 4, no. 3, pp. 526–530, Sep. 1989.
- [8] L. Shridhar, B. Singh, C. Jha, B. Singh, and S. Murthy, "Selection of capacitors for the self regulated short shunt self excited induction generator," IEEE Trans. Energy Convers., vol. 10, no. 1, pp. 10–17, Mar. 1995.
- [9] L. Wang and C.-H. Lee, "Long-shunt and short-shunt connections on dynamic performance of a SEIG feeding an induction motor load," IEEE Trans. Energy Convers., vol. 15, no. 1, pp. 1–7, Mar. 2000.
- [10] M. B. Brennen and A. Abbondanti, "Static exciters for induction generators," IEEE Trans. Ind. Appl., vol. IA-13, no. 5, pp. 422–428, Sep. 1977.
- [11] B. Singh, S. Murthy, and S. Gupta, "STATCOMbased voltage regulator for self-excited induction generator feeding nonlinear loads," IEEE Trans. Ind. Electron., vol. 53, no. 5, pp. 1437–1452, Oct. 2006.
- [12] E. Larsen, N. Miller, S. NiSsson and S. Lindgren, "Benefits of GTObased compensation systems for electric utility applications," IEEE Trans, on Power Delivery, Vol. 7, No. 4, pp. 2055-2064, October 1997.
- [13] C. Schauder and H. Mehta, "Vector analysis and control of advanced static VAR compensator," IEE Proc.-C, Vol. 140, No. 4, pp.299-306, July 1993.
- [14] T. Chan and L. L. Lai, "A novel single-phase selfregulated self-excited induction generator using a three-phase machine," IEEE Trans. Energy Convers., vol. 16, no. 2, pp. 204–208, Jun. 2001.
- [15] T. Chan, "Performance analysis of a three-phase induction generator selfexcited with a single capacitance," IEEE Trans. Energy Convers., vol. 14, no. 4, pp. 894–900, Dec. 1999.