



COPY RIGHT

2017 IJIEMR. Personal use of this material is permitted. Permission from IJIEMR must be obtained for all other uses, in any current or future media, including reprinting/republishing this material for advertising or promotional purposes, creating new collective works, for resale or redistribution to servers or lists, or reuse of any copyrighted component of this work in other works. No Reprint should be done to this paper, all copy right is authenticated to Paper Authors

IJIEMR Transactions, online available on 24th Oct 2017. Link

[:http://www.ijiemr.org/downloads.php?vol=Volume-6&issue=ISSUE-9](http://www.ijiemr.org/downloads.php?vol=Volume-6&issue=ISSUE-9)

Title: **A GRID INTERFACING SCHEME USING FUZZY CONTROLLED SYSTEM TO MITIGATE HARMONICS**

Volume 06, Issue 09, Pages: 231– 238.

Paper Authors

NSS PRITHVI, SREEPAL REDDY

Scient Institute of Engineering & Technology, Hyderabad) Telangana, India.



USE THIS BARCODE TO ACCESS YOUR ONLINE PAPER

To Secure Your Paper As Per **UGC Guidelines** We Are Providing A Electronic Bar Code

A GRID INTERFACING SCHEME USING FUZZY CONTROLLED SYSTEM TO MITIGATE HARMONICS

¹NSS PRITHVI, ²SREEPAL REDDY

¹M-tech Scholar, Department of Electrical & Electronics Engineering, Scientist Institute of Engineering & Technology, Hyderabad) Telangana, India.

²Assistant Professor, Department of Electrical & Electronics Engineering, Scientist Institute of Engineering & Technology, Hyderabad) Telangana, India.

¹prithvi.nss@gmail.com, ²sreepalid@gmail.com

ABSTRACT: Renewable energy sources like wind, sun, and hydro are seen as a reliable alternative to the traditional energy sources such as oil, natural gas, or coal. Distributed power generation systems (DPGSs) based on renewable energy sources experience a large development worldwide. As a consequence, the control of distributed generation systems should be improved to meet the requirements for grid interconnection. This concept presents the development of a control scheme for grid tied inverters of renewable energy sources (RES). Hysteresis Current Control (HCC) is carried out in this work. In HCC the inverter output current is forced to follow the grid voltage in terms of the time phase. The actual grid current is measured and compared with the reference current which is the unit sine wave obtained from the grid, and the pulses are generated according to the error between the actual current and the grid current. The power delivered to the grid increases as the DC link voltage increases. The inverter is also tested on grid interface on the rotor side of a doubly fed induction generator. In extension the proposed concept can be implemented for Fuzzy logic controller scheme for PV cell based multilevel inverter by using MATLAB/SIMULATION software.

KEYWORDS: Wind power, Distribution Network, Induction Generator, STATCOM, Reactive Power, Harmonics, and Power Quality.

I. INTRODUCTION

Due to increasing air pollution, global warming concerns, diminishing fossil fuels and their increasing cost have made it necessary to look towards Renewable Energy Sources (RES) as a future energy solution. In finding solutions to overcome a global energy crisis, the Photo Voltaic (PV) system has attracted significant attention in recent years. The government is providing incentives for further increasing the use of grid-connected PV systems. Renewable Energy Sources are increasingly integrated at the distribution level due to increase in load demand which utilize power electronic converters. Due to the extensive use of power electronic devices, disturbances occur in the

electrical supply network. These disturbances are due to the use of non-linear devices. These will introduce harmonics in the power system thereby causing equipment overheating, damage devices, EMI related problems etc. Active Power Filters (APF) is extensively used to compensate the current harmonics and load unbalance. This will result in additional hardware requirements. So, in this paper, the existing PV inverter acts as Shunt Active Power Filter (SAPF) that is capable of simultaneously compensating problems like current unbalance, current harmonics and also of injecting the energy generated by RES. The shunt active filter is a voltage source inverter

(VSI), which is connected in parallel with load. Shunt Active Power Filter has the ability to keep the mains current balanced and sinusoidal after compensation for various Load conditions.

II.SYSTEM DESCRIPTION

A. TOPOLOGY Active power filters are power electronic devices that cancel out unwanted harmonic currents by injecting a compensation current which cancels harmonics in the line current. Shunt active power filters compensate load current harmonics by injecting equal-but opposite harmonic compensating current. Generally, APFs have been conceived using voltage source converters [5]. This topology has proved better controllability. In this paper, it is shown that using an adequate control strategy, even with a three phase four-wire system, The topology of the investigated APF and its interconnection with the grid is presented in Fig. 1. It consists of a three-leg three-wire voltage source inverter. In this type of applications, the VSI operates as a current controlled voltage source. The proposed system is Three Phase three wire which consists of Photovoltaic system and fuel cell connected to the dc-link of a grid-interfacing inverter as shown in Fig. 1. The voltage source inverter is a key element as it interfaces the renewable energy source to the grid and delivers the generated power. The RES is connected to grid with an inverter coupled to dc-link. The dc-capacitor decouples the Photovoltaic system from grid and also allows independent control of converters on either side of dc-link.

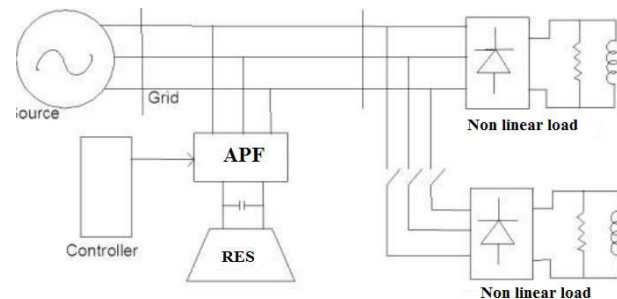

Fig 1.Schematic of the 3 phase grid system interface with renewable energy source using APF

B.VOLTAGE SOURCE CONVERTER (VSC)

A Voltage Source Converter (VSC) is a power electronic device that connected in shunt or parallel to the system. It can generate a sinusoidal voltage with any required magnitude, frequency and phase angle. It also converts the DC voltage across storage devices into a set of three phase AC output voltages. It is also capable to generate or absorbs reactive power. If the output voltage of the VSC is greater than AC bus terminal voltages, is said to be in capacitive mode. So, it will compensate the reactive power through AC system. The type of power switch used is an IGBT in anti-parallel with a diode. The three phase four leg VSI is modeled in Simulink by using IGBT.

C.CONTROLLER FOR APF

The dc link voltage, V_{dc} is sensed at a regular interval and is compared with its reference counterpart V_{dc}^* . The error signal is processed in a PI-controller. The output of the pi controller is denoted as I_m . The reference current templates (I_a^* , I_b^* , and I_c^*) are obtained by multiplying this peak value (I_m) by the three-unit sine vectors (U_a , U_b and U_c) in phase with the three source voltages. These unit sine vectors are obtained from the three sensed line to neutral voltages. The reference grid neutral current (I_n^*) is set to zero, being

the instantaneous sum of balanced grid currents. Multiplication of magnitude I_m with phases (U_a , U_b , and U_c) results in the three phase reference supply currents (I_a^* , I_b^* , and I_c^*).

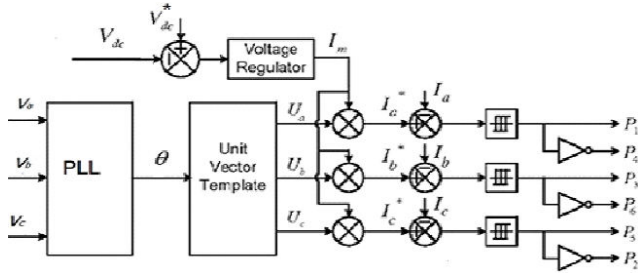

Fig. 2. Block diagram representation of grid-interfacing inverter control.

The grid synchronizing angle (θ) obtained from phase locked loop (PLL) is used to generate unity vector.

$$U_a = \sin(\theta) \quad (1)$$

$$U_b = \sin\left(\theta - \frac{2\pi}{3}\right) \quad (2)$$

$$U_c = \sin\left(\theta + \frac{2\pi}{3}\right) \quad (3)$$

The actual dc-link voltage (V_{dc}) is sensed and passed through a first-order *low pass filter* (LPF) to eliminate the presence of switching ripples on the dc-link voltage and in the generated reference current signals. The difference of this filtered dc-link voltage and reference dc-link voltage (V_{dc}^*) is given to a discrete-PI regulator to maintain a constant dc-link voltage under varying generation and load conditions. The dc-link voltage error $V_{dcerr}(n)$ at nth sampling instant is given as:

$$V_{dcerr}(n) = V_{dc}^*(n) - V_{dc}(n) \quad (4)$$

The output of discrete-PI regulator at the sampling instant is expressed as

$$I_m(n) = I_m(n-1) + K_{PV_{dc}}(V_{dcerr}(n) - V_{dcerr}(n-1)) + K_{IV_{dc}}V_{dcerr}(n) \quad (5)$$

Where $K_{PV_{dc}} = 10$ and $K_{IV_{dc}} = 0.05$ are proportional and integral gains of dc-voltage regulator. The instantaneous values of reference three phase grid currents are computed as

$$I_a^* = I_m \cdot U_a \quad (6)$$

$$I_b^* = I_m \cdot U_b \quad (7)$$

$$I_c^* = I_m \cdot U_c \quad (8)$$

The reference grid currents (I_a^* , I_b^* , I_c^*) are compared with actual grid currents (I_a , I_b , I_c) to compute the current errors as

$$I_{aerr} = I_a^* - I_a \quad (9)$$

$$I_{berr} = I_b^* - I_b \quad (10)$$

$$I_{cerr} = I_c^* - I_c \quad (11)$$

These current errors are given to hysteresis current controller. The hysteresis controller then generates the switching pulses (P_1 to P_8) for the gate drives of grid-interfacing inverter. The switching pattern of each IGBT inside inverter can be formulated on the basis of error between actual and reference current of inverter, which can be explained as: If $I_{Inva} < (I_{Inva}^* - h_b)$, then upper switch S_1 will be OFF ($P_1 = 0$) and lower switch S_4 will be ON ($P_4 = 1$) in the phase “a” leg of inverter. If $I_{Inva} > (I_{Inva}^* + h_b)$, then upper switch S_1 will be ON ($P_1 = 1$) and lower switch S_4 will be OFF ($P_4 = 0$) in the phase “a” leg of inverter Where h_b is the width of hysteresis band. On the same principle, the

switching pulses for the other remaining three legs can be derived.

III. HYSTERESIS CONTROLLER

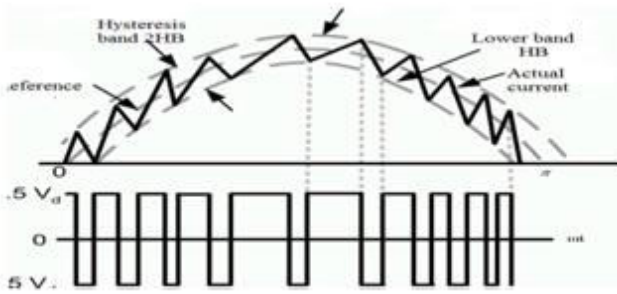

Fig.3. Hysteresis current Modulation

With the hysteresis control, limit bands are set on either side of a signal representing the desired output waveform [6]. The inverter switches are operated as the generated signals within limits. The control circuit generates the sine reference signal wave of desired magnitude and frequency, and it is compared with the actual signal. As the signal exceeds a prescribed hysteresis band, the upper switch in the half bridge is turned OFF and the lower switch is turned ON. As the signal crosses the lower limit, the lower switch is turned OFF and the upper switch is turned ON. The actual signal wave is thus forced to track the sine reference wave within the hysteresis band limits.

IV INTRODUCTION TO FUZZY LOGIC CONTROLLER

L. A. Zadeh presented the first paper on fuzzy set theory in 1965. Since then, a new language was developed to describe the fuzzy properties of reality, which are very difficult and sometime even impossible to be described using conventional methods. Fuzzy set theory has been widely used in the control area with some application to dc-to-dc converter system. A simple fuzzy logic control is built up by a group of rules based on the human knowledge of system behavior. Matlab/Simulink

simulation model is built to study the dynamic behavior of dc-to-dc converter and performance of proposed controllers. Furthermore, design of fuzzy logic controller can provide desirable both small signal and large signal dynamic performance at same time, which is not possible with linear control technique. Thus, fuzzy logic controller has been potential ability to improve the robustness of dc-to-dc converters. The basic scheme of a fuzzy logic controller is shown in Fig 5 and consists of four principal components such as: a fuzzification interface, which converts input data into suitable linguistic values; a knowledge base, which consists of a data base with the necessary linguistic definitions and the control rule set; a decision-making logic which, simulating a human decision process, infer the fuzzy control action from the knowledge of the control rules and linguistic variable definitions; a de-fuzzification interface which yields non fuzzy control action from an inferred fuzzy control action [10].

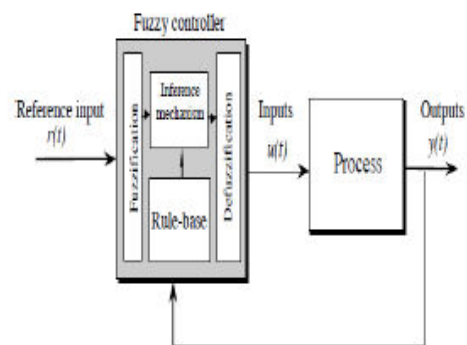

Fig.4. General Structure of the fuzzy logic controller on closed-loop system

The fuzzy control systems are based on expert knowledge that converts the human linguistic concepts into an automatic control strategy without any complicated mathematical model [10]. Simulation is performed in buck converter to verify the proposed fuzzy logic controllers.

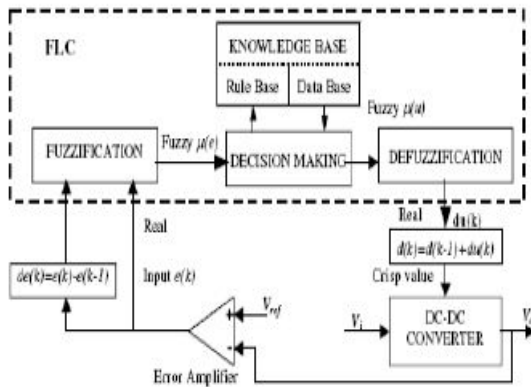
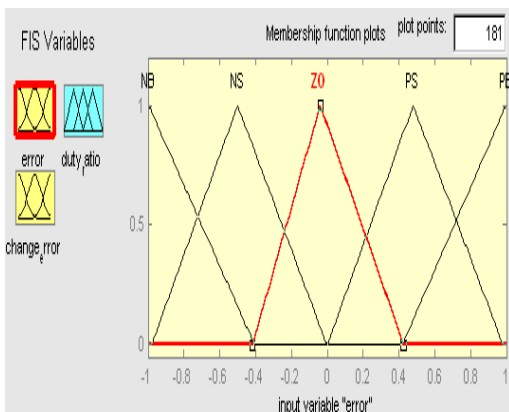

Fig.5. Block diagram of the Fuzzy Logic Controller (FLC) for dc-dc converters

A. Fuzzy Logic Membership Functions:

The dc-dc converter is a nonlinear function of the duty cycle because of the small signal model and its control method was applied to the control of boost converters. Fuzzy controllers do not require an exact mathematical model. Instead, they are designed based on general knowledge of the plant. Fuzzy controllers are designed to adapt to varying operating points. Fuzzy Logic Controller is designed to control the output of boost dc-dc converter using Mamdani style fuzzy inference system. Two input variables, error (e) and change of error (de) are used in this fuzzy logic system. The single output variable (u) is duty cycle of PWM output.



The Membership Function plots of error

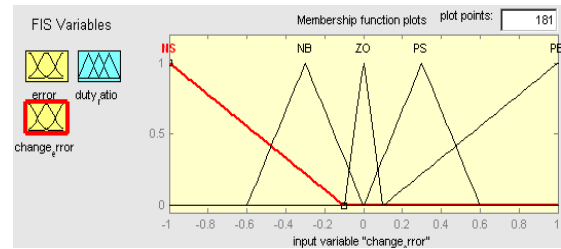

The Membership Function plots of change error

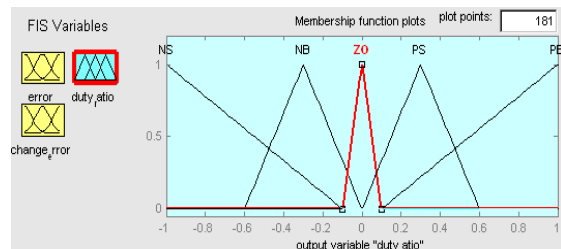

the Membership Function plots of duty ratio

B. Fuzzy Logic Rules:

The objective of this dissertation is to control the output voltage of the boost converter. The error and change of error of the output voltage will be the inputs of fuzzy logic controller. These 2 inputs are divided into five groups; NB: Negative Big, NS: Negative Small, ZO: Zero Area, PS: Positive small and PB: Positive Big and its parameter [10]. These fuzzy control rules for error and change of error can be referred in the table that is shown in Table II as per below:

Table II

Table rules for error and change of error

(de) \ (e)	NB	NS	ZO	PS	PB
NB	NB	NB	NB	NS	ZO
NS	NB	NB	NS	ZO	PS
ZO	NB	NS	ZO	PS	PB
PS	NS	ZO	PS	PB	PB
PB	ZO	PS	PB	PB	PB

V. MATLAB MODELEING AND SIMULATION RESULTS

Fig.5 Matlab/Simulink Model of proposed power circuit, along with control circuit. The power circuit as well as control system are modeled using Power System Block set and Simulink. The grid source is represented by three-phase AC source. Three-phase AC loads are connected at the load end. APF is connected in shunt and it consists of PWM voltage source inverter circuit and a DC capacitor connected at its DC bus. An IGBT-based PWM inverter is implemented using Universal bridge block from Power Electronics subset of PSB. Snubber circuits are connected in parallel with each IGBT for protection. Simulation of APF system is carried out for linear and non-linear loads.

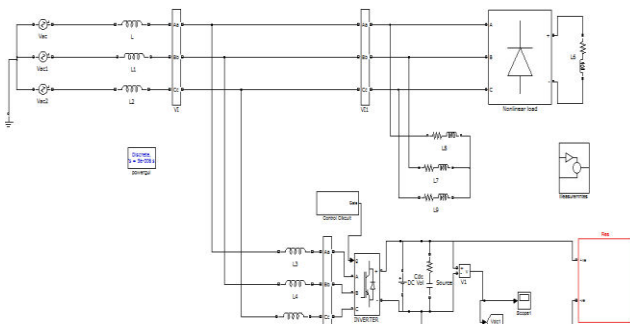

Fig.6 Matlab/Simulink of Proposed Statcom-Power Circuit

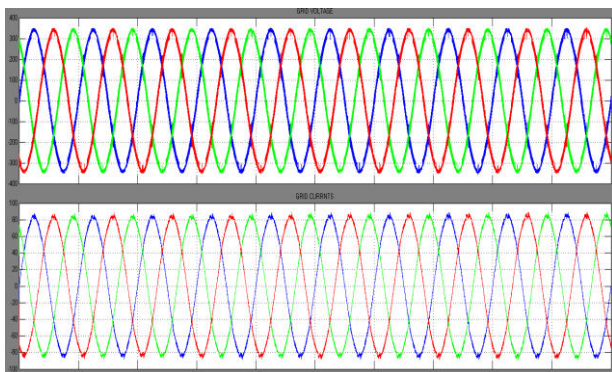

Fig.7 simulation results for grid side voltages and current

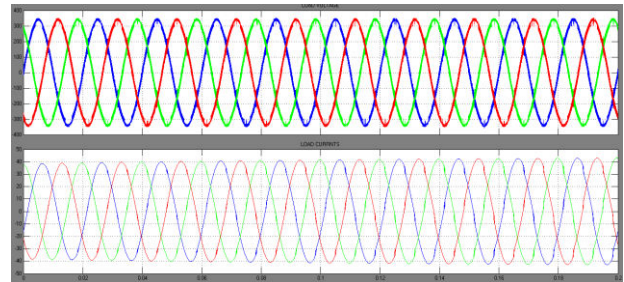

Fig.8 simulation results for load voltage and current

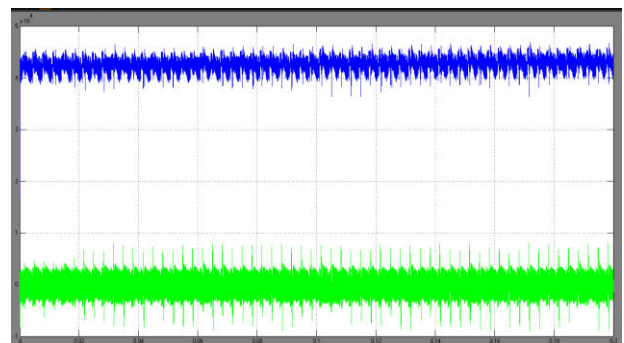

Fig.9 simulation results for active and reactive power

From fig. 6 we know that if non linear load present at the grid side the current shapes are sinusoidal, then we can improve the power quality of the system.

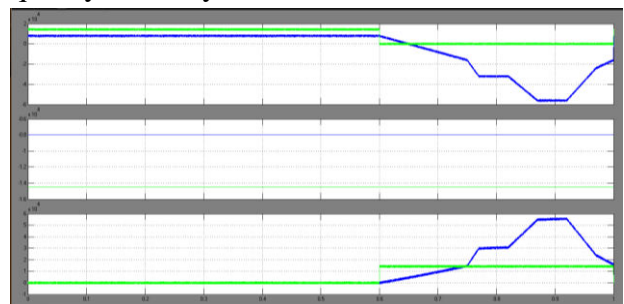

Fig 10 simulation wave form of power voltage and current source and load side and also line voltage and current

VI. CONCLUSION

In this paper the APF -based fuzzy logic control scheme for power quality improvement in grid connected renewable energy system and with several load conditions are presented. The power quality issues and its consequences on the consumer and electric utility are discussed.

The operation of the control system developed for the APF in MATLAB/SIMULINK for maintaining the power quality is simulated. It has a capability to cancel out the harmonic parts of the grid current. It support the reactive power demand for the PV and load at PCC in the grid system, giving an opportunity to enhance the power quality in the transmission line. This paper analysed a control of three phase grid interfacing inverter improve the quality of power at PCC for a 3 phase 3 wire system applied to various load conditions, here we preferred linear & non-linear load. This also makes real power flow at instantaneous demand of the load. Rapid injection or absorption of reactive/real power flow in the power system can be made possible through battery energy storage and APF

REFERENCES

- [1] J. O .Q. Tande 'Applying Power Quality Characteristics of wind turbine for Assessing impact on Voltage Quality', Wind Energy, pp 52, 2002.
- [2] G.Satyanarayana., K.N.V Prasad, G.Ranjith Kumar, K. Lakshmi Ganesh, "Improvement of power quality by using hybrid fuzzy controlled based IPQC at various load conditions," Energy Efficient Technologies for Sustainability (ICEETS), 2013 International Conference on , vol., no., pp.1243,1250, 10-12 April 2013..
- [3] L. H. Hansen, L. Helle, F. Blaabjerg, E. Ritchie, S. Munk-Nielsen, H. Binder, P. S0rensen and B. Bak - Jensen "Conceptual Survey of Generators and Power Electronics for Wind Turbines ", Ris0 National Laboratory, Roskilde, Denmark, December 2001.
- [4] A.Arulampalam, M.Bames & NJenkins, Power quality and stability improvement of a wind farm using ST A TCOM, Proc. TEE Generation, Transmission & Distribution, Vol. 153, No.6, 2006, 701-710.
- [5] G. Satyanarayana, K.Lakshmi Ganesh , CH. Narendra Kumar, N. Srinivasa Rao "Realization of Hybrid Active Power Filter Applied to BLDC Motor Drive Using Dual Instantaneous Power Theory", International Journal of Engineering Associates, Vol-1, Issue 3, p.p. 32-37, Feb, 2013..
- [6] A.Arulampalam, I.B.Ekanayake & NJenkins, Application study of a ST A TCOM with energy storage, Proc. IEE Generation, Transmission & Distribution, Vol. 150, No. 3, 2003, 373-384.
- [7] Fang Zheng Peng, Jih-Sheng Lai, 'Generalized Instantaneous Reactive Power Theory for Three-phase Power Systems', IEEE on instrumentation and measurement, vol. 45, no. I, Feb,1996.
- [8] G. Satya Narayana, Ch. Narendra Kumar, Ch. Rambabu " A Comparative Analysis of PI Controller and Fuzzy Logic Controller for Hybrid Active Power Filter Using Dual Instantaneous Power Theory" International Journal of Engineering Research & Development, Vol-4, Issue-6, p.p. 29-39, Oct, 2012.
- [9] Fang Zheng Peng, , George W. Ott, Jr., and Donald J. Adams,' Harmonic and Reactive Power Compensation Based on the Generalized Instantaneous Reactive Power Theory for Three-Phase Four-Wire Systems' IEEE Trans on power electronics, vol. 13, no. 6, nov 1998.
- [10] Leszek S. Czamecki:Instantaneous Reactive Power p-q Theory and Power Properties of Three-Phase Systems' IEEE Trans on power delivery', vol. 21, no. I, Jan 2006.
- [I I] K. Derradji Belloum, and A. Moussi, 'A Fixed Band Hysteresis Current Controller for Voltage Source AC Chopper' World Academy of Science, Engineering and Technology 45 2008.



[12] I. Dalessandro, U. Drofenik, S. D. Round and I. W. Kolar, 'A Novel Hysteresis Current Control for Three-Phase Three-Level PWM Rectifiers', Swiss Federal Institute of Technology (ETH) Zurich, Power Electronic Systems Laboratory.

[13] D. Dragomir, N. Golovanov, P. Postolache, C. Toader, 'The connection to the grid of wind turbines'.