



COPY RIGHT

2017 IJIEMR. Personal use of this material is permitted. Permission from IJIEMR must be obtained for all other uses, in any current or future media, including reprinting/republishing this material for advertising or promotional purposes, creating new collective works, for resale or redistribution to servers or lists, or reuse of any copyrighted component of this work in other works. No Reprint should be done to this paper, all copy right is authenticated to Paper Authors

IJIEMR Transactions, online available on 16th Oct 2017. Link

[:http://www.ijiemr.org/downloads.php?vol=Volume-6&issue=ISSUE-9](http://www.ijiemr.org/downloads.php?vol=Volume-6&issue=ISSUE-9)

Title: **MANUFACTURING TECHNIQUES FOR CERAMIC COATED PISTON BY USING CAD/CAE**

Volume 06, Issue 09, Pages: 138– 145.

Paper Authors

¹MR. KONATHAM SATISH, ²DR.BANOTH MOHAN

¹St.Marys college of engineering and technology, Hyderabad

²Dilla University, College of engineering and technology,Dilla



USE THIS BARCODE TO ACCESS YOUR ONLINE PAPER

MANUFACTURING TECHNIQUES FOR CERAMIC COATED PISTON BY USING CAD/CAE

¹MR. KONATHAM SATISH, ²DR. BANOTH MOHAN

¹Asst. Professor, Mechanical Department, St. Marys college of engineering and technology, Hyderabad

²Asst. Professor, School of Mechanical and automotive Engineering, Dilla University, College of engineering and technology, Dilla.

¹konathamsatish86@gmail.com, ²banothmohan2012@gmail.com

ABSTRACT Now days, internal combustion engines are used in most of the automobiles and mechanical machineries. The piston is a part without which no internal combustion engine can work i.e., piston plays a vital role in almost all types of vehicles. So, the reliability of piston manufacturing system is most essential for the proper functioning of vehicles. A piston is a disc which reciprocates within a cylinder. It is either moved by the fluid or it moves the fluid which enters the cylinder. The main function of the piston of an IC engine is to receive the impulse from the expanding gas and to transmit the energy to the crankshaft through the connecting rod. The piston must also disperse a large amount of heat from the combustion chamber to the cylinder walls. Cast iron, Aluminum Alloy and Cast Steel etc. are the common materials used for piston of an Internal Combustion Engine. In this project here we were taken steel is an existing material and aluminum is another material. The aim of my project is to model a piston for a two wheeler using theoretical calculations, designing with Creo software. The main objective piston is investigate and analyze the thermal stress distribution of piston at the real engine condition during combustion process, in this process we applied temperature and convection as boundary conditions and we determining total temperature on the body, total heat flux values. In this process I am also discussing about energy efficient and best manufacturing method to produce ceramic coating more efficiently on piston.

Key Words: CREO Tool, Piston, Total heat flux, Ceramic coating.

1. INTRODUCTION

1.1 INTRODUCTION The depletion of fossil fuel resources at a faster rate in the present world of economic competitiveness is generating an essential demand for increase in efficiency of internal PISTONS On the basis of head formation Deflector head piston combustion chamber type piston Domed and depression headed piston. On the basis of skirt profile Slipper piston

Cutway piston On the basis of skirt piston solid skirt piston split skirt piston On the basis of other specialties Cam ground piston Taper piston Oval piston combustion engines. The use of coating in the automotive industry has been found to yield a significant effect on the efficiency of engines. Higher the operating temperature more will be the efficiency of the system.

However, such higher temperatures demand for enhanced temperature resistant materials to be used, that is thermal insulating materials (commonly known as thermal barrier coatings). The first use of Thermal barrier coating (TBC) was for aircraft engine performance. The concept of thermal barrier coating for diesel engines began in 1980s. The petroleum crisis and the subsequent increase in the cost of fuels, the improvement of fuels and the improvement of fuel economy of the I.C Engines has become a high priority to the researchers. Numerous investigations have modelled and analyzed the effects of in-cylinder thermal insulation. Reducing heat rejection in reciprocating engines is a possible way of reducing fuel consumption. This may be possible by eliminating a part of the cooling system and incorporating high-temperature insulating materials in the combustion chamber to withstand the higher combustion gas temperature. The advent of high temperature, high performance ceramics has tempted engine researchers to strive for higher operating temperatures with subsequent higher engine thermal efficiency by reducing fuel consumption. Various types of pistons are employed on different engines. This is because each type fulfils some specific requirements on a particular engine. Some pistons have complex head formation, some have specially formed skirts, and other have geometrical peculiarities.



Fig 1.1: Hierarchal representation of piston types

2. LITURATURE REVIEW

S. Lakshmanan¹ G. Ranjith Babu² S. Sabesh³ M. Manikandan⁴[1]

According to the First law of thermo dynamics, thermal energy is conserved by reducing the heat flow to the cooling and exhaust systems. It's known that only one third of energy is converted into useful work, theoretically if rejection of heat is reduced then the thermal efficiency likely to be increased. To a considerable extent. The Application of TBC decreases the heat transfer to the cooling and exhaust system which ultimately results in the high temperature gas and high temperature combustion chamber wall which reduces the level of smoke and hydrocarbon (HC) emission. In particular, for the latter, durability concerns for the materials and components in the engine cylinders, which include piston, rings, liner, and cylinder head, limit the allowable in-cylinder temperatures. The application of thin TBCs to the surfaces of these components enhances high temperature durability by reducing the heat transfer and lowering

temperatures of the underlying metal. In this article, the main emphasis is placed on investigating the effect of aTBC on the engine fuel consumption with the support of detailed sampling of in-cylinder pressure. **X.Q. Cao*,a, R. Vassenb, D. Stoeverb[2]** During the past decade, research efforts were devoted to the development and manufacturing of ceramic thermal barrier coatings (TBCs) on turbine parts because the traditional turbine material have reached the limits of their temperature capabilities. TBCs are deposited on transition pieces, combustion lines, first-stage blades and vanes and other hot-path components of gas turbines either to increase the inlet temperature with a consequent improvement of the efficiency or to reduce the requirements for the cooling system. Several ceramic coatings such as Al₂O₃, TiO₂, mullite, CaO/MgO+ZrO₂, YSZ, CeO₂+YSZ, zircon and La₂Zr₂O₇, etc. have been evaluated as TBC materials. 1,5The number of materials that can be used as TBCs is very limited. So far, only a few materials have been found to basically satisfy these requirements. In Ref. 6 the development of new TBC systems is described. Properties of thermal expansion coefficient and thermal conductivity seem to be the most important. These data are collected from different references and hence may not be complete

Jing Zhang a, Xingye Guoa, Yeon-Gil Jung b, Li Lic, James Knapp c[3] Thermal barrier coatings are multi-layer coating systems deposited on turbine components, especially turbine blade, which thermally

insulate and protect them against hot and corrosive gas streams [1–3]. Typical structure of TBCs includes four layers: (1) super alloy substrate; (2) bond coat; (3) thermally grown oxide (TGO); and (4) ceramic top coat. Typically, TBCs can be deposited directly on the substrate using various techniques, such as air plasma spraying (APS), electron-beam physical vapor deposition (EB-PVD), high velocity oxygen-fuel (HVOF) spraying, vacuum plasma spraying, low-pressure plasma spraying and diffusion bond method [5–8]. This review article summarizes the latest information about the manufacturing techniques of lanthanum zirconate (La₂Zr₂O₇, LZ) powder and La₂Zr₂O₇ based thermal barrier coatings (TBCs). Lanthanum zirconate is a promising candidate material for TBC applications, due to its lower thermal conductivity and higher thermal stability compared to other traditional TBC systems. In this work, the physical, thermal, and mechanical properties of the powder and coatings are evaluated. The durability experiments of the TBCs in various thermal, mechanical, and corrosive conditions are also reviewed. In addition, theoretical studies on the powder and coatings properties are presented.

D.S. Patil, K. Prabhakaran*, Rajiv Dayal, C. Durga Prasad, N.M. Gokhale, A.B. Samui, S.C. Sharma.” [4]. An organic precursor-mixing route has been developed for preparation of 8 mol% yttria stabilized zirconia (8YSZ) ceramics. Polymeric salt of succinic acid with yttrium and zirconium has been prepared separately by treating

sodium succinate with yttrium chloride and zirconyl chloride followed by washing with water and drying at 1200C. Thorough mixing of the two salts in stoichiometric proportions by planetary ball milling followed by calcination at 8500C resulted in a precursor powder containing nanocrystalline (40 nm) monoclinic zirconia, tetragonal YSZ, cubicYSZ and yttria. Compacts prepared after deagglomeration of powder by planetary ball milling produce 8YSZ ceramics having density 99.3% TDon sintering at 1550 0C for 2 hr.

3. DESCRIPTION

3.1 DESIGNING IN CAD DESIGN TOOL (CREO) The design calculations for piston design were as follows.

Pressure Calculations

$$\text{Mean effective pressure } P_m = \frac{T_{nc}}{V_d} \times 2\pi$$

$$= \frac{13.4 \times 2 \times 2 \times 3.14}{149.5} = 1.12 \text{ N/mm}^2$$

$$\text{Indicated power IP} = \frac{P_m \times l \times A \times n}{60} = \frac{P_m \times l \times \pi \times D^2 \times n}{60} = \frac{1.12 \times 58.6 \times 3.14 \times 57^2 \times 4}{4 \times 60} = 11217.05 \text{ kW}$$

$$\text{Brake power BP} = \frac{2\pi NT}{60} = \frac{2\pi \times 6000 \times 13.4}{60} = 8415.2$$

$$\text{Mechanical efficiency } \eta_{mech} = \frac{BP}{IP} = \frac{8415.2}{11217.05} = 0.75 = 75\%$$

Piston Specifications

1. Thickness of piston head

2. $t_h = \left(\frac{h}{12.56k(\tau_c - \tau_p)} \right)$
3. $t_h = 258.5 / (12.56 \times 174.75 \times 75)$
4. $t_h = 0.00157\text{m}$
5. $t_h = 1.57\text{mm}$
6. $t_h = 5.45\text{mm}$

2. Piston rings

The gap between the free ends of the ring = $3.5t$ to $4t = 7.72\text{mm}$

3. Piston barrel

The piston wall thickness towards the open end

$$t_4 = 0.35t_3 = 2.989\text{mm}$$

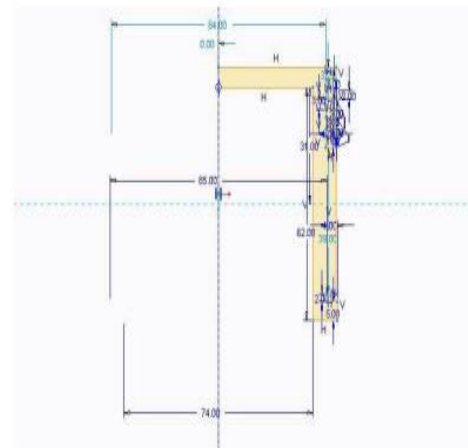

Fig 3.1: Creating model with dimensions

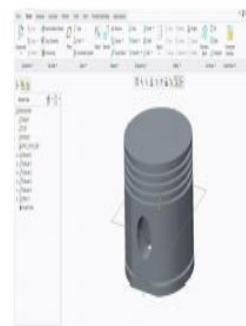

Fig 3.2: Modeled Piston



Fig 3.3: Ceramic coated piston with 0.4mm coating layer

So the modeling of piston with 0.4mm thick layer is completed by using CREO design software.

3.2 ANSYS ANALYTICAL SYSTEM For all engineers and students coming to finite element analysis or to ANSYS software for the first time, this powerful hands-on guide develops a detailed and confident understanding of using ANSYS's powerful engineering analysis tools. The best way to learn complex systems is by means of hands-on experience.

3.2.1 Static ANSYS Process

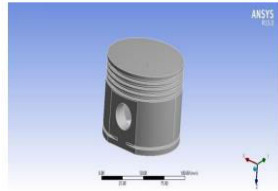

Fig 3.4: Model imported from CREO

Pictorial analysis of uncoated piston with materials Steel and al-alloy. The figures are shown below.

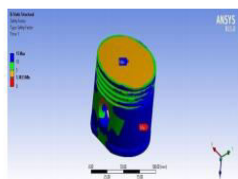

Fig 3.5: Safety factor of Steel

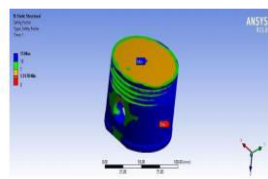

Fig 3.5: Safety factor of Al-alloy

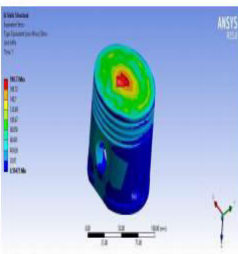

Fig 3.7: Stress of Steel

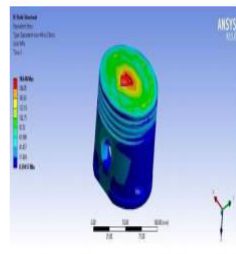

Fig 3.8: Stress of Al-alloy

Pictorial analysis of coated piston with materials Lanthanum zirconate and steel 8YSZ. The figures are shown below

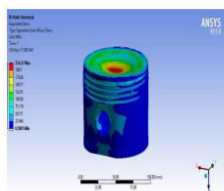

Fig 3.9: Stress of Lanthanum zirconate

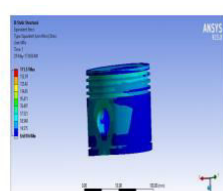

Fig 3.8: Stress of steel 8YSZ

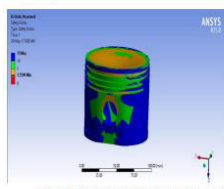

Fig 3.10: Safety factor of Lanthanum zirconate

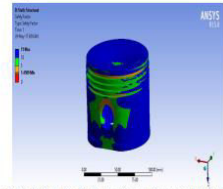

Fig 3.11: Safety factor of steel 8YSZ

3.2.2 Thermal ANSYS Process Pictorial analysis for thermal analysis of uncoated piston with materials Steel and al-alloy. The figures are shown below.

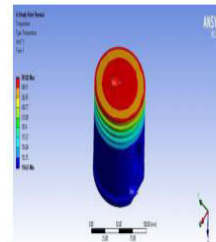

Fig 3.12: Total temperature of Steel

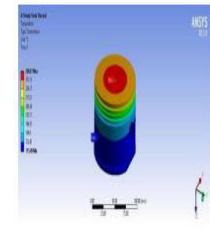

Fig 3.13: Total temperature of Al-alloy

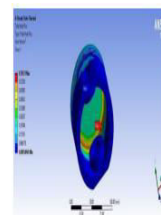

Fig 3.14: Total heat flux of Steel

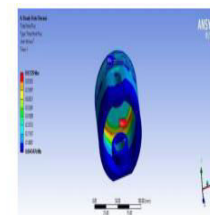

Fig 3.15: Total heat flux of Al-alloy

Pictorial thermal analysis of coated piston with materials Lanthanum zirconate and steel 8YSZ. The figures are shown below.

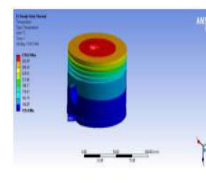

Fig 3.16: temperature of Lanthanum zirconate

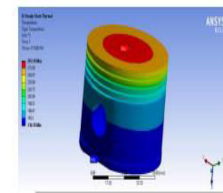

Fig 3.17: temperature of steel 8YSZ

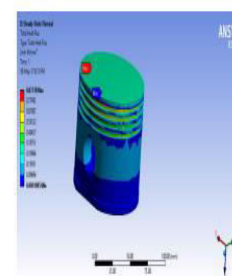

Fig 3.18: heat flux of Lanthanum zirconate

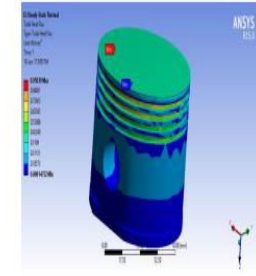

Fig 3.19: heat flux of steel 8YSZ

4. RESULT

The following tables and graphs are obtained from analysis such as deformation, strain, stress, factor of safety. The results are illustrated in the following tables.

Results of Uncoated piston

Table 4.1 uncoated piston result values

Material	Deformation(mm)	Safety factor	Strain	Stress(Mpa)
Steel	0.11397	1.3833	0.0009061	180.73
Al-alloy	0.31606	1.5178	0.002605	184.48

Results of Coated piston

Table 4.2 coated piston result values

Material	Deformation(mm)	Safety factor	Strain	Stress(Mpa)
steel-LZ	0.096929	1.5599	0.000929	224.37
steel & 8YSZ	0.11125	1.459	0.000888	171.37

The thermal analyzed results are presented in the below tables.

Results of Uncoated piston

Table 4.3 uncoated piston result values

Material	Heat flux(w/mm ²)	Temp(°c)
Steel	0.59121	305.82
Al-alloy	0.93729	268.07

Results of Coated piston

Table 4.4 coated piston result values

Material	Heat flux(w/mm ²)	Temp(°c)
Steel-lanthanum zirconate	0.788735	408.91
Steel-8YSZ	0.80179	393.98

The graphical representations are shown below graphs.

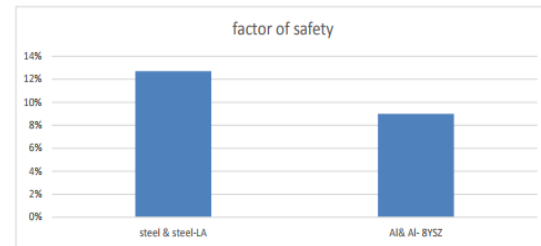

Fig 4.1 comparing percentages of factor of safety graph

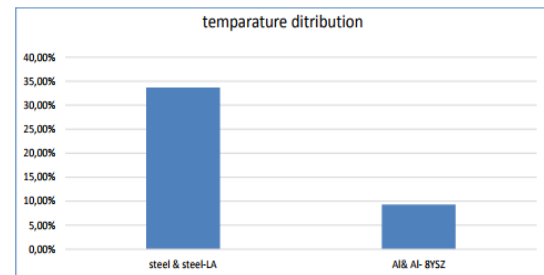

Fig 4.2 comparing percentages of temperature distribution graph

5. CONCLUSION

In this project we have done one piston model by using CAD tool (creo-2) and then imported into CAE tool (Ansys). For improve results here we selected another material steel and existing material is Al-AlloyA360 only. And applied real time boundary conditions on it but in this case we got good results for existing material only. So we decide to change the design. For changing design here we added 0.4mm thickness material on the top surface which is called ceramic coating and we used two materials for this one is Lanthanum zirconate and 8YSZ we analyses for both steel and al-alloy pistons with these coatings. In static conditions when we applied 6Mpa pressure on steel piston produced 180.73Mpa by changing design and adding lanthanum zirconate coating

stress are increased but the factor of safety is increased by 12.7% so the strength of piston is increased and also in real time conditions these results are not enough so we have analysis these models with thermal loads also. In thermal analysis steel piston gained temperature 305.820 °C only by changing design steel-lanthanum zirconate gained 408.0 °C and steel-8YSZ gained 393.980 °C. Ceramic coating increased exhaust gases temperatures at every operational condition. Exhaust gases temperatures were increased 90 to 1000°C according to standard engine configuration. This increase corresponds to 15 to 25 percent of standard engine exhaust gases temperatures. When a turbine is combined to the system, aforementioned excess of exhaust energy can be converted to useful mechanical energy. From the above we can say in thermal conditions steel-lanthanum zirconate combination produces better results compare with other. And it also has good static results. Finally we conclude steel with lanthanum zirconate ceramic coated piston will satisfy both static and thermal conditions, and it increases the piston efficiency

6. REFERENCES

- [1] S. Lakshmanan¹ G. Ranjith Babu² S. Sabesh³ M. Manikandan⁴ "Investigation of Thermal Barrier Coating on I.C Engine Piston. International Journal for Research in Applied Science & Engineering Technology (IJRASET) Special Issue-1, October 2014, ISSN: 2321-9653
- [2] X.Q. Cao^{*,a}, R. Vassen^b, D. Stoeve^b "Ceramic materials for thermal barrier coatings", Journal of the European Ceramic Society 24 (2004) 1–10, Received 30 June 2002; received in revised form 20 February 2003; accepted 7 March 2003
- [3] Jing Zhang ^{a,✉}, Xingye Guo^a, Yeon-Gil Jung ^b, Li Lic, James Knapp ^c "Lanthanum zirconate based thermal barrier coatings: A review" Article history: Received 26 June 2016, Revised 4 October 2016, Accepted in revised form 5 October 2016
- [4]. D.S. Patil, K. Prabhakaran*, Rajiv Dayal, C. Durga Prasad, N.M. Gokhale, A.B. Samui, S.C. Sharma."Eight mole percent yttria stabilized zirconia powders by organic precursor route Ceramic Division", Naval Materials Research Laboratory, Defence Research and Development Organization, ShilBadlapur Road, Anandnagar P.O., Addl. Ambernath, Thane 421506, India
- [5].S.Sathyamoorthi¹, M.Prabhakaran², S.A.Muhammed Abraar³ "Numerical investigation of ceramic coating on piston crown using Finite Element Analysis" International Journal of Scientific Engineering and Applied Science (IJSEAS) , www.ijseas.com ,– Volume-2, Issue- 4, April 2016 ISSN: 2395-3470
- [6] Vishnu Sankar "thermal barrier coatings material selection, method of preparation and applications – review, ISSN 2278 – 0149 ,www.ijmerr.com Vol. 3, No. 2, April, 2014 © 2014 IJMERR. All Rights Reserved
- [7] Ravinder Reddy P., Ramamurthy G., "Computer Aided Analysis of Thermally Air Gap Insulated Pistons made of Composites",

National Conference on Machines and Mechanisms (NACOMM-95), pp. 177-180, Jan 20-21, 1995, CMERI, Durgapur. [8] K. BalaShowry, A.V.S. Raju, P. Ravinder Reddy, "Multi-Dimensional Modeling of Direct Injection Diesel Engine and Effects of Split Injection", International Journal of Scientific and Research Publications, Volume 2, Issue 1, pp. 1-8, January 2012

[8] Pradeep Halder, Edla Franklin, Dr. P. Ravinder Reddy, "Combustion and Mixing Analysis of a Scramjet Combustor Using CFD", International Journal for Scientific Research & Development (IJSRD), Vol. 2, Issue 09, pp. 27-33, 2014

[9] Dr. K. BalaShowry, Dr. P. Ravinder Reddy, "Reducing Particulate and NOX Emissions by Using Split Injection", International Journal of Science and Research, Volume 4, Issue 3, March 2015.

[9] T.M. Yonushonis, "Overview of thermal barrier coatings in diesel engines", J. Therm. Spray Technol. 6, pp. 50-56, 1997.

[10] M. Cerit, "Thermo mechanical analysis of a partially ceramic coated piston used in an SI Engine", Surf. Coat. Technol. 205, pp. 3499-3505, 2011.

[11] E. Buyukkaya, "Thermal analysis of functionally graded coating AlSi alloy and steel pistons", Surf. Coat. Technol. 202, pp. 3856-3865, 2008.

[12] E. Buyukkaya, M. Cerit, "Thermal analysis of a ceramic coating diesel engine piston using 3D finite element method", Surf. Coat. Technol. 202, pp. 398-402, 2007.

[13] H.W. Ng, Z. Gan, "A finite element analysis technique for predicting as-sprayed residual stresses generated by the plasma spray coating process", Finite Elem. Anal. Des. 41 pp. 1235-1254, 2005.

[14] E. Buyukkaya, A.S. Demirkıran, M. Cerit, "Application of thermal barrier coating in a diesel engine", Key Eng. Mater. 264e268, 517e520, 2004

[15] E. Buyukkaya, M. Cerit, "Experimental study of NOx emissions and injection timing of a low heat rejection diesel engine", Int. J. Therm. Sci. v47, 1096e1106, 2008

[16] A. Parlak, V. Ayhan, "Effect of using a piston with a thermal barrier layer in a spark ignition engine", J. Energy Inst. V80, 223e228, 2007

[17] E. Buyukkaya, T. Engin, M. Cerit, "Effects of thermal barrier coating on gas emissions and performance of a LHR engine with different injection timings and valve adjustments", Energy Convers. Manage. v47, 1298e1310, 2006

[18] M. Cerit, V. Ayhan, A. Parlak, H. Yasar, "Thermal analysis of a partially ceramic coated piston: effect on cold start HC emission in a spark ignition engine", Appl. Therm. Eng. 31 (2-3), pp. 336-341, 2011