



International Journal for Innovative Engineering and Management Research

A Peer Reviewed Open Access International Journal

www.ijiemr.org

COPY RIGHT

2017 IJIEMR. Personal use of this material is permitted. Permission from IJIEMR must be obtained for all other uses, in any current or future media, including reprinting/republishing this material for advertising or promotional purposes, creating new collective works, for resale or redistribution to servers or lists, or reuse of any copyrighted component of this work in other works. No Reprint should be done to this paper, all copy right is authenticated to Paper Authors

IJIEMR Transactions, online available on 16th Aug 2017. Link

[:http://www.ijiemr.org/downloads.php?vol=Volume-6&issue=ISSUE-7](http://www.ijiemr.org/downloads.php?vol=Volume-6&issue=ISSUE-7)

Title: RTOS BASED ADVANCED VEHICLE SECURITY SYSTEM FOR BEST CONTROLLING

Volume 06, Issue 07, Pages: 207 – 212.

Paper Authors

¹SHAIK ASHA, ²SK.LALJOHN BASHA



USE THIS BARCODE TO ACCESS YOUR ONLINE PAPER

To Secure Your Paper As Per **UGC Guidelines** We Are Providing A Electronic Bar Code

RTOS BASED ADVANCED VEHICLE SECURITY SYSTEM FOR BEST CONTROLLING

¹SHAIK ASHA, ²SK.LALJOHN BASHA

¹PG Scholar, Dept of ECE., ²M.Tech, Asst.Professor, Dept Of E.C.E.

ABSTRACT: In the proposed system Design and development of Vehicular monitoring, tracking and Accident Identification system using RASPBERRY PI is presented. here The vehicular module is used to track, monitor, and surveillance and finds the accident spot and intimate to the monitoring station. The proposed design provides information regarding vehicle Identity, and position on real time basis. This information are collected by the RASPBERRY PI by using different modules like Sensors and GPS, and dispatch it to the monitoring station where it stores the information in database and display it on graphical user interface (GUI) that is user friendly. Here we are using the GSM and internet connectivity to dispatch the information to monitoring station.

Keywords: Global Positioning System (GPS), Global System for Mobile Communications (GSM), tracking.

1. OBJECTIVE

To minimize the risk involved in vehicle stealing and providing accident notification to reduce the loss of lives.

2. INTRODUCTION

These day's vehicle robbery cases are higher than any other time, it has gotten to be fundamental to give a vehicle a superb security with the main solid hostile to burglary gadget. Vehicle focal locking framework guarantees the best ensure to secure your vehicle from various types of burglary cases. It is a vehicle security gadget that offers fantastic insurance to your vehicle. Whether one is holder of single vehicle or in excess of 1000, Vehicle Tracking System (VTS) is an answer for spot, track and secure your portable resources.

GPS Module:

Stands for "Global Positioning System." GPS is a satellite navigation system used to determine the ground position of an object. The Global Positioning System (GPS) is a space based radio-navigation system consisting of a constellation of satellites and a network of ground stations used for monitoring and control. GPS is operated and maintained by the Department of Defense (DOD). It is the receiver that collects data from the satellites and computes its location anywhere in the world based on information it gets from the satellites.

GSM Module:

A **GSM modem** is a specialized type of modem which accepts a SIM card, and operates over a subscription to a mobile operator, just like a mobile phone. From the

mobile operator perspective, a GSM modem looks just like a mobile phone. While these GSM modems are most frequently used to provide mobile internet connectivity, many of them can also be used for sending and receiving SMS and MMS messages. In most parts of the world, GSM modems are a cost effective solution for receiving SMS messages, because the sender is paying for the message delivery.

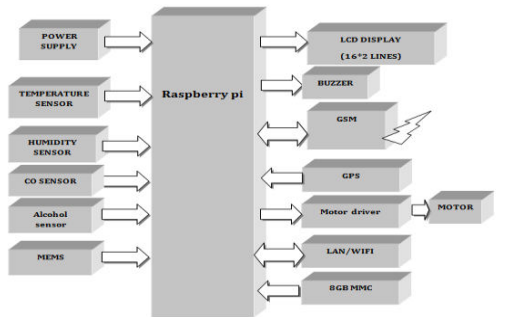

Fig-1: Block diagram of Advanced Vehicle Security System

3. BRIEF REVIEW

The created framework makes utilization of an inserted framework focused around GSM innovation. An interfacing mobile or GSM modem is associated with the microcontroller, which in term is joined with the engine through relay. In the event that the vehicle is stolen, the data is sent to the owner that somebody has stolen his vehicle. After that the user or owner will send the message to GSM modem or mobile which is joined with motor ignition through transfer or relay to switch off the engine. GPS based tracking system that keeps track of the location of a vehicle and its speed based on a mobile phone text messaging system. The system is able to provide real-time text alerts for speed and location. The present location can be locked and the system will alert the

owner if the vehicle is moved from its present locked location. In every one hour the GSM modem or mobile will inform the owner by messaging its location in the form of latitude, longitude and speed information. The owner or user can control or stop the vehicle by simply sending the message stop to GSM modem or mobile connected to circuitry board. After receiving that message ignition system will turn off.

4. HARDWARE DESCRIPTION

A. GSM Model:

The hardware design is split into two parts- GSM and GPS. The main circuit is divided into two circuits one is for detecting the motion of thief using infrared sensors and other is for DTMF tone decoding for switching on/off the relay. The block diagram (Fig. 2), when thief tries to unlock the car, the infrared sensors placed near the car door will sense the motion or movement and will sent the signal to 8051 microcontroller. The microcontroller which is connected to triggering circuit will send the triggering signal to relay. The relay is connected to GSM mobile through earphone. The microcontroller will send triggering signal three times to GSM mobile and call will be made to user informing him or her that someone is trying to unlock the vehicle.

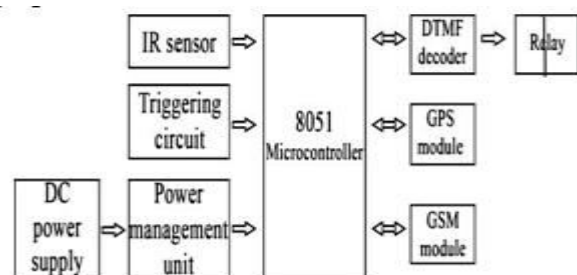

Fig. 2. Anti-theft system architecture.

The second part is for controlling or switching different systems like engine ignition, fuel supply, electric shock mesh and windscreen paint spray using relay. The relay is controlled using GSM mobile and DTMF tone decoder. DTMF tone detection and decoding is provided by IC MT8870DE. This circuit detects the dial tone from a telephone line and decodes the keypad pressed on the remote telephone. The dial tone we heard when we pick up the phone set is called Dual Tone Multi-Frequency, DTMF in short. The name was given because the tone that we heard over the phone is actually making up of two distinct frequency tones, hence the name dual tone. The DTMF tone is a form of one way communication between the dialer and the telephone exchange.

we are use the IC MT8870DE, the main component to decode the input dial tone to 5 digital outputs. These digital bits can be interface to a computer or microcontroller for further application. There is particular range of frequency (Fig. 4) for each keypad number which will be decoded by DTMF decoder circuit. Depending upon the system like ignition cut-off, fuel supply cut-off, windscreen paint spray and electric shock mesh, the number of relays controlling them will be added. There are four relays in the circuit each one of them controlling the preventive system like engine ignition cut-off. The owner will send the DTMF tone to the GSM mobile placed in the car. The DTMF tone will be decoded using IC MT8870DE which will be controlling relays to activate security system. For example number 1 on the mobile keypad is assigned for engine ignition cut-off, on pressing 1 number on the keypad of your mobile phone, the DTMF decoder will decode the keypad tone frequency and microcontroller will switch the relay on-off depending upon the program burn in the microcontroller.

A complete communication consists of the tone generator and the tone decoder. Here we are use the IC MT8870DE, the main component to decode the input dial tone to 5 digital outputs. These digital bits can be interface to a computer or microcontroller for further application. There is particular range of frequency (Fig. 4) for each keypad number which will be decoded by DTMF decoder circuit. Depending upon the system like ignition cut-off, fuel supply cut-off, windscreen paint spray and electric shock mesh, the number of relays controlling them

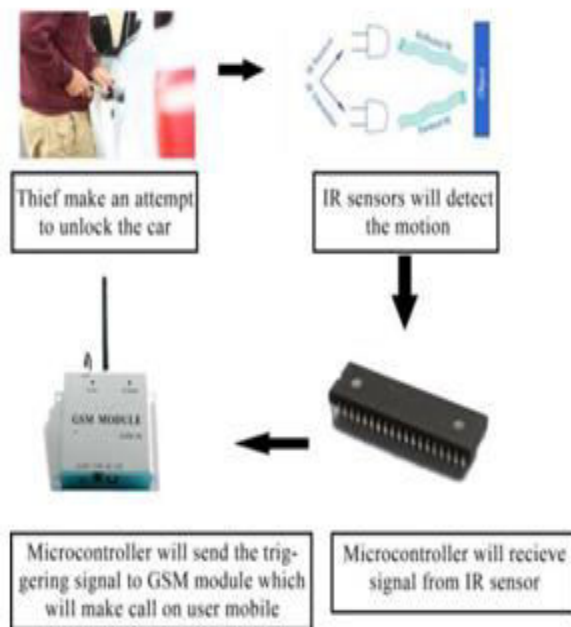

Fig. 3. Block diagram for detecting thief movement.

A complete communication consists of the tone generator and the tone decoder. Here

will be added. There are four relays in the circuit each one of them controlling the preventive system like engine ignition cut-off. The owner will send the DTMF tone to the GSM mobile placed in the car. The DTMF tone will be decoded using IC MT8870DE which will be controlling relays to activate security system. For example number 1 on the mobile keypad is assigned for engine ignition cut-off, on pressing 1 number on the keypad of your mobile phone, the DTMF decoder will decode the keypad tone frequency and microcontroller will switch the relay on-off depending upon the program burn in the microcontroller.

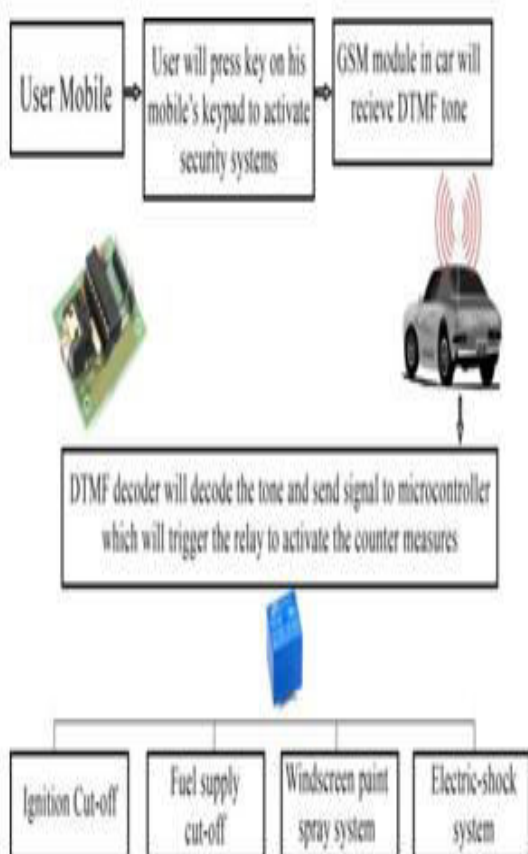

Fig. 4. Block diagram for switching different systems using DTMF decoder circuit using relay.

The mechanism of security system is presented through a block diagram in Fig.3. Whenever someone attempts to unlock the vehicle, the security system is automatically turned ON. Firstly, the system is checking the modem and starting the vibration sensor detect the vibration when the GSM modem response OK. If the sensor is first detect, the system activate alarm only. When the system occur second detection during 30 seconds, the system will be activated alarm and send SMS message to the owner's GSM. And a next detection occurs over 30 seconds, the alarm always turn ON and then it send SMS to the user. In the security system, it is needed to ground the reset pin for the alarm turn OFF.

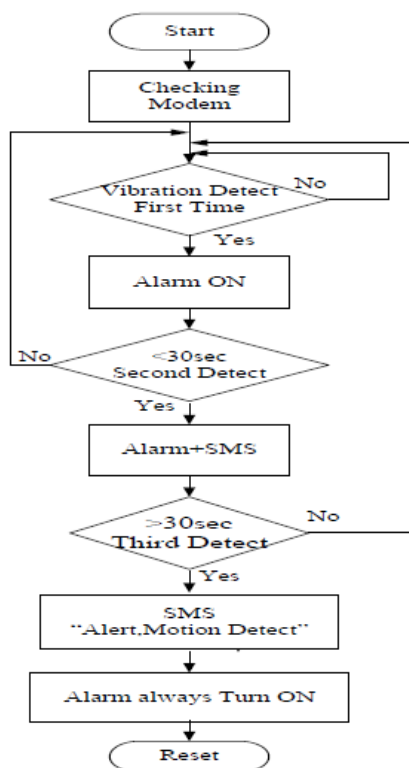

Fig 5: Flowchart of Advanced Car Security System using GSM

The Flow Chart of the system is shown in the figure 6. It shows the system is initialized on power ON. When the system is detected to be abnormal, it is confirmed that the accident has occurred. The vibration/acceleration of the vehicle is detected to confirm the cause of the accident. As soon as the accident is detected the buzzer (alarm) is ON. The switch is scanned first; if it is a minor accident then the switch is ON so that messaging is terminated. If it is a major accident, the switch remains OFF and the message is sent automatically to the rescue team after the location is detected by the GPS.

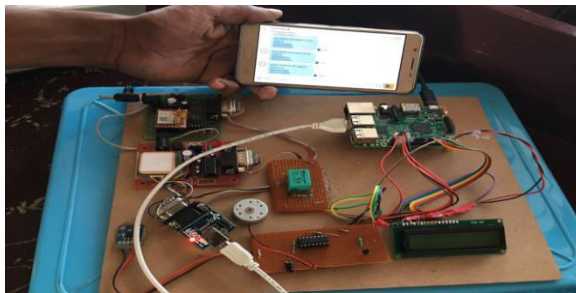

Fig 7 Implemented circuit

5. CONCLUSION

The aim of the paper is to give an overview of vehicle tracking and vehicle accident detection system. This Vehicle accident detection system can track geographical information automatically and sends an alert SMS regarding accident. Experimental work has been carried out carefully. The result shows that higher sensitivity and accuracy. This system is verified to be highly beneficial for the automotive industry.

REFERENCES

[1] M.S. Joshi, Deepali V. Mahajan, "Arm 7 Based Theft Control, Accident Detection & Vehicle Positioning System,"

[2] International Journal of Innovative Technology and Exploring Engineering (IJITEE) ISSN: 2278-3075, Volume-4 Issue-2, July 2014.

[3] Mr.S.Iyyappan,Mr.V.Nandagopal, "Automatic Accident Detection and Ambulance Rescue with Intelligent Traffic Light System," International Journal of Advanced Research in Electrical, Electronics and Instrumentation Engineering Vol. 2, Issue 4, April 2014.

[4] Montaser N. Ramadan, Mohammad A. Al-Khedher, Senior Member, IACSIT, and Sharaf A. Al-Kheder, "Intelligent Anti-Theft and Tracking System for Automobiles," International Journal of Machine Learning and Computing, Vol. 2, No. 1, February 2013.

[4] NiravThakor, Tanmay Vyas, Divyang Shah, "Automatic Vehicle Accident Detection System Based on ARM &GPS," International Journal for Research in Technological Studies, ISSN: - Applied (Online) Vol-1, Issue - 1, Dec 2012.

[5] VarshaGoud,V.Padmaja, "Vehicle Accident Automatic Detection and Remote Alarm Device," International Journal of Reconfigurable and Embedded Systems (IJRES). Vol. 1, No. 2, July 2012, pp. 49~54 ISSN: 2089-4864.

[6] J. M. Hu, J. Li, and G. H. Li, "Automobile anti-theft system based on

GSM and GPS module,” presented at the Fifth International Conference on Intelligent Networks and IntelligeSystems, Tianjin, China, November 1201

Author details:



SHAIK ASHA, PG Scholar, Dept of ECE. Eswar college of Engineering, Narasarao
petSHAIKLALJOHNBASHA_{M.TECH},
Asst. Professor, Dept Of ECE, Eswar college of Engg Narasarao pet
mail:sk.laljohangmail.com