



International Journal for Innovative Engineering and Management Research

A Peer Reviewed Open Access International Journal

www.ijiemr.org

COPY RIGHT



2022 IJIEMR. Personal use of this material is permitted. Permission from IJIEMR must be obtained for all other uses, in any current or future media, including reprinting/republishing this material for advertising or promotional purposes, creating new collective works, for resale or redistribution to servers or lists, or reuse of any copyrighted component of this work in other works. No Reprint should be done to this paper, all copy right is authenticated to Paper Authors

IJIEMR Transactions, online available on 16th Feb 2022. Link

[:http://www.ijiemr.org/downloads.php?vol=Volume-11&issue=ISSUE-02](http://www.ijiemr.org/downloads.php?vol=Volume-11&issue=ISSUE-02)

DOI: 10.48047/IJIEMR/V11/I02/21

Title **AUTOMATIC DOOR OPENING SYSTEM BASED ON HUMAN BODY TEMPERATURE**

Volume 11, Issue 02, Pages: 157-162

Paper Authors

B. Balaji Bhanu, P. Nanda Shanmukha Nath, K. Pavan Kalyan



USE THIS BARCODE TO ACCESS YOUR ONLINE PAPER

To Secure Your Paper As Per **UGC Guidelines** We Are Providing A Electronic Bar Code

AUTOMATIC DOOR OPENING SYSTEM BASED ON HUMAN BODY TEMPERATURE

¹B. Balaji Bhanu

balajibattu@gmail.com

Andhra Loyola College

Vijayawada – 520 008

²P. Nanda Shanmukha Nath

aec182919@gmail.com

Andhra Loyola College

Vijayawada – 520 008

³K. Pavan Kalyan

aec182907@gmail.com

Andhra Loyola College

Vijayawada – 520 008

Abstract:

The proposed work is about an integrated sensors platform for non-contact temperature monitoring of a person's keeping in view of the COVID pandemic situation. In this work it is described the design and implementation of automatic controller for the door to open depending on the temperature. The door opens when any human body temperature is detected nearer to the door with the help of contactless sensor (MLX90614SE). If the detected body temperature is above the normal, then sound of alarm is listened by the security persons for immediate action. The total setup contains an Arduino Uno Microcontroller, sensors, speakers and buzzer. This setup is installed at the entrance of an office or an organization to check the temperature of individuals before they are entering into that vicinity.

Keywords: Temperature, Buzzer, Pandemic, Contactless sensor.

Introduction

COVID 19 made a huge impact on the civilization, and the new restrictions has been forced to maintain along with social distancing regular temperature checks at the entrances of shopping malls, the offices is compulsory. In this project we arranged the room where such compulsory precautions are taken, by making use of a laser diode and receiver to detect the entry of a person. This experimentation checks the temperature of the person at the entrance of the door steps. If the temperature is less than the normal human body temperature the person is allowed at the entrance, otherwise the entry is denied by the security. So, this project, developed

for the safety of public to oppose the covid spreading.

As per WHO specifications the Physical/Social distancing of one meter is recommended as one of the solutions to stop the spread of COVID-19. The people are coming in and out in the public entrances and exit gates in scenarios then there is a circumstances that people would come close in contact with each other. The main motto of this project is to open the door with an embedded system equipped with sensors.

Literature Review

An Automatic sliding door System using an infrared sensor project tried to fulfill the IoT technology implementation with an electronic door lock making it a super

advanced door opener cum locking system [1]. The objective of achieving automation and security is simultaneously achieved using web connectivity of the project with Internet of Things is controlled by AT Mega family microcontroller.

The automatic doors locally available in Nigeria are all imported which introduces leanness to the nation's foreign exchange and not only that, they have high cost [2]. The high cost is reduced by removing the sensors and its circuitry which crisscross the door panel and jamb profiles. The aim of the work is to design, develop and test an automatic door assembly using locally available raw materials at low cost.

Microcontroller ATMEGA328

The **ATmega328** is a single-chip microcontroller. It has a modified Harvard architecture 8-bit RISC processor core. Atmega328 microcontroller is used in basic Arduino Uno, Arduino Pro Mini and Arduino Nano.

1. The ATmega328P microcontroller is used as a Arduino board it receives the data from sensors and operate the other devices.

2. In this project we used this board to receive the analog signals from sensors and send digital signals to the other devices like LCD.



Fig.1 Microcontroller Board

Pin description of Microcontroller

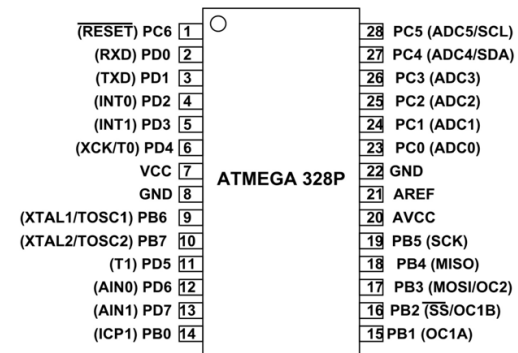

ATmega328 Pins			
Pin Number	Pin Name	Pin Number	Pin Name
1	PC6	15	PB1
2	PD0	16	PB2
3	PD1	17	PB3
4	PD2	18	PB4
5	PD3	19	PB5
6	PD4	20	AVCC
7	Vcc	21	AREF
8	GND	22	GND
9	PB6	23	PC0
10	PB7	24	PC1
11	PD5	25	PC2
12	PD6	26	PC3
13	PD7	27	PC4
14	PB0	28	PC5

Programing the Microcontroller

There are two modes in which the Microcontroller is programmed are namely Serial and parallel.

Working of MLX90614

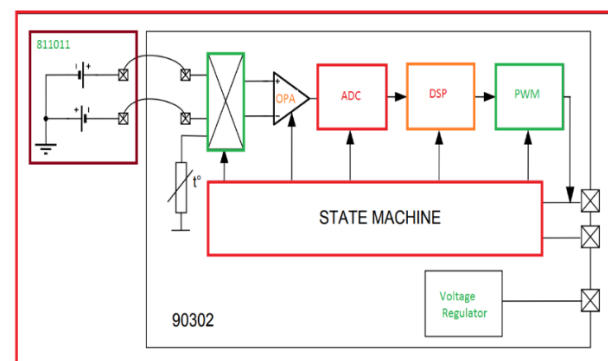

2.4 Pin description of temperature sensor

Pin#	Type	Parameters
Pin#1	VSS	It is a ground pin.
Pin#2	SCL	It is Serial Clock input for a protocol of two wire. At this pin, there is a Zener diode of 5.7V to connect it with other Bipolar transistors.
Pin#3	PWM / SDA	It is digital input and output pin, the measured value of temperature can get by this pinout.
Pin#4	VDD	It is an external power supply.

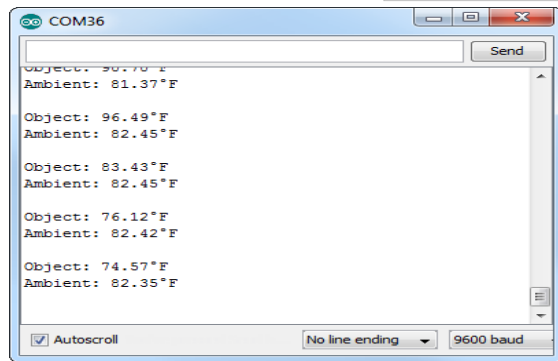
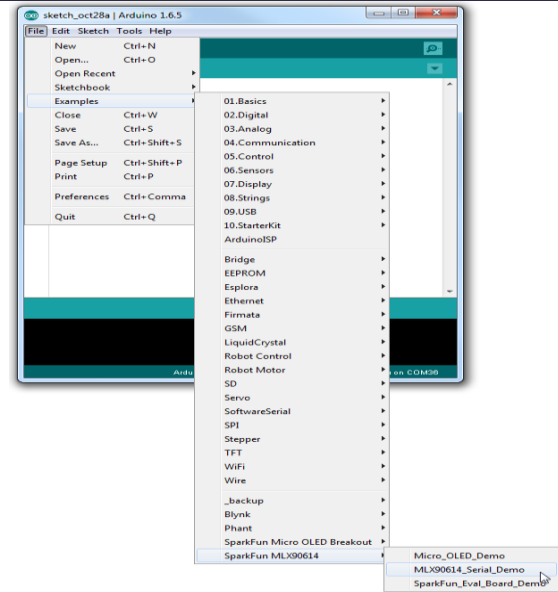

Programming

ARDUINO library for MLX90614SE

Using Arduino library, an Arduino board is interacted with the sensor IR Thermometer.

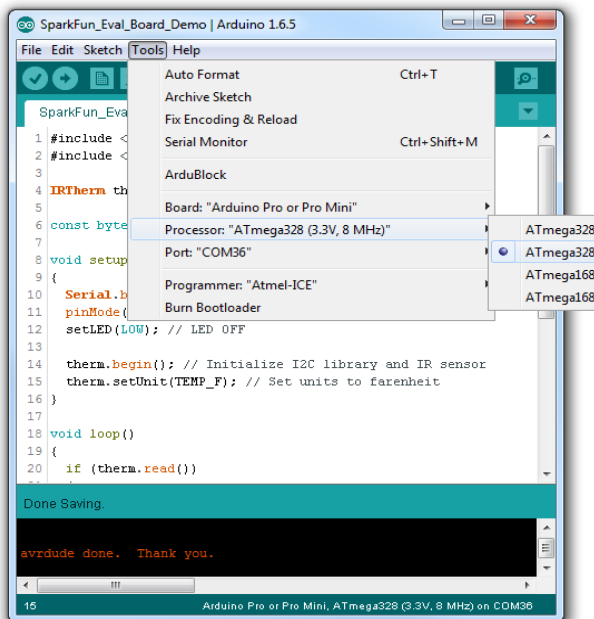

Implementation

1. The significant goal of the project is to provide a fast and accurate tool for touch free, finding the body temperature by avoiding any direct contact with people.
2. This project describes the design of automatic door controller based on human body temperature.
3. In this project we use contactless temperature sensor (mlx90614SE), for reading the body temperature.

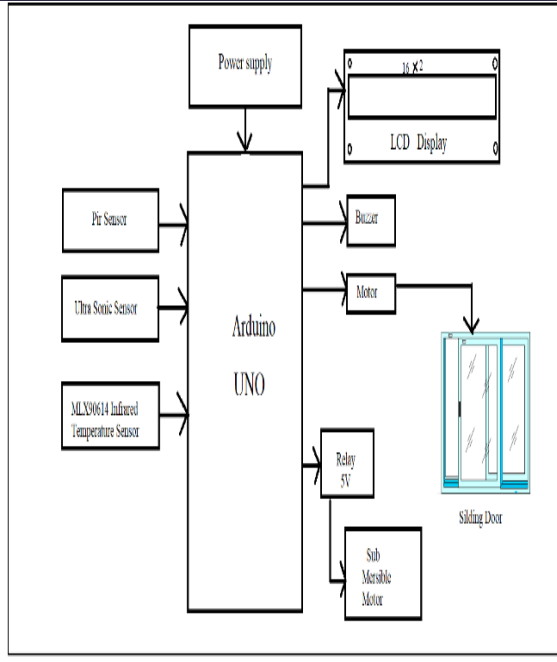

Fig.3 Block diagram of the project
Sequence of the operation for door opening



Fig.4 Before Entering the Door



Fig.5 Kit loads the data



Fig. 6 When the kit detects the person, it checks the temperature and allows the person if he has less than 100°F, a message was pop up as



Fig. 7 The temperature of the person will be shown if he want to check it.



Fig. 8 A sanitizer arranged at the door will be started and sprinkles the sanitizer.



Fig. 9 After sanitization is completed, the door will be opened if temperature was less than 100°F, closes automatically after 5 seconds.



Fig. 10 Door in Closed State

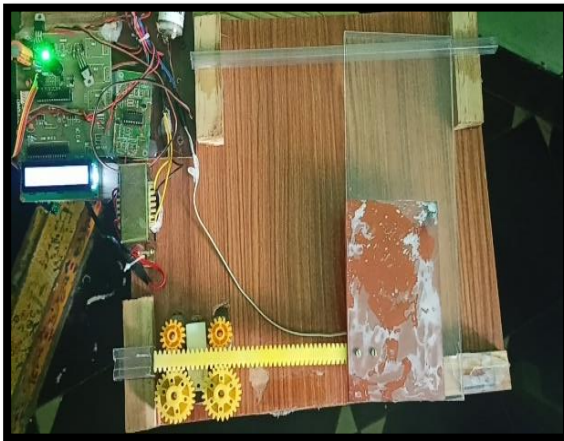

Fig. 11 Door in Open State

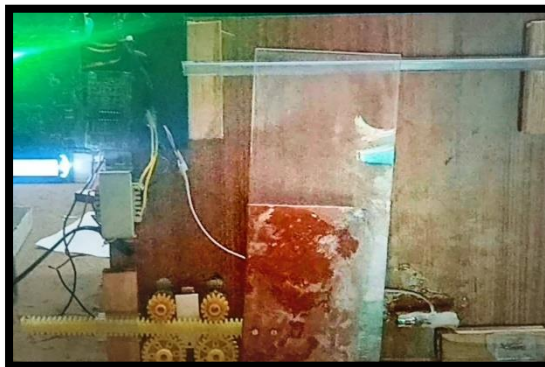

Fig. 12 Door in Close State

Working Process

1. At the entrance of the door IR sensor is used to detect the human body within the range of 5cm.
2. After detection of human body it activates mlx90614SE that is contactless temperature sensor.

3. Now contactless temperature sensor senses the temperature of the human body within the range of 5cm.
4. Then, the readings from the contactless temperature sensor sent to the ATmega328P microcontroller board.
5. The temperature readings will be displayed on LCD as ambient and body temperature.
6. Then Atmega328P microcontroller check the following conditions.
7. If the temperature is greater than 98.6F, the buzzer will continuously make sound and a warning message is displayed on LCD that is "YOU ARE NOT ALLOWED".
8. If temperature is lesser than 98.6F, then microcontroller sent the command to TIP122 relay for spraying sanitizer per second.
9. After the sanitizer sprayed, the microcontroller gives the command to the door motor driver(L293d).
10. The motor driver will rotate the 30RPM DC motor for door opening, after 5seconds the door closes automatically.

Advantages

- 1) It is very convenient to entering.
- 2) Low cost. 3) Easy to use. 4) It reduces the covid spreading 5) Power is consumption is very less.

Disadvantages

- 1) Continues power supply is required.
- 2) It will not allow so many people at a time.
- 3) Easily manipulation of circuit was done.

Conclusion

- This system is designed for automatic door opening using contactless body temperature sensor.

- It checks the body temperature and sanitize hands at the entrance sequentially.

Future Scope

- There can be a display unit for showing number of persons entered in a particular room.
- Can be further used in security systems by implementing finger print on it.

References

- [1]. Olodumoya M and Olowatomi A. A, "An Automatic sliding door System using an infrared sensor", Development Informatics and Allied Research Journal (DIARJ),5(4), 2014, pp.1169-1174.
- [2]. Chomo DIG. Yawas DS and Johnson ZS, " Development of An Automatic door System", American Journal of Engineering Research(AJER),7(5),2018,pp.168-173.
- [3].Pik-Yiu Chan, John Enderl,"Automatic Door Opener", Institute of Electrical and Electronics Engineers(IEEE),8(7),2015,pp.139-140.
- [4]. Sandra Costanzo and Alexandra Flores," A Non-contact Integrated Body Ambient Temperature Sensor platform to contrast COVID-19", Multidisciplinary Digital publishing Institute (MDPI),9(2),2020, pp.1-17.
- [5]. Papor Hazarika, Papor Hazarika and BuhumshriNarzary," Automatic door opening and closing using PIR sensor",International Research Journal of Engineering(IRJET),7(3),2020,pp.4351-4356.
- [6]. Tondare SM, Kondekar Priyanka .P, Shinde Sneha N, Momin Seema A," IoT Based Door Opener Using Arduinio", International Journal of Advanced Research in Electrical, Electronics and Instrumentation Engineering.,8(5), 2019,pp. 1585-1590.
- [7].Daiki Nishida, Kumiko Tsuzura, Shunsuke Kudoh, Kazuo Takai,

Tatsuhiko Momodori, Norihiro Asada, Toshihiro Mori, Takashi Suehiro and Tetsuo Tomizawa," Development of Intelligent Automatic Door System", International Conference on Robotics & Automation (ICRA),6(4),2014,pp.6368-6374.

[8]. Vinod BG, Tejas A," Implementation of Automatic Contactless Temperature Sensing and Door Access", International Journal of Advanced Research in Computer and Communication Engineering,9(6), 2020, pp.44-46.