



International Journal for Innovative Engineering and Management Research

A Peer Reviewed Open Access International Journal

www.ijiemr.org

COPY RIGHT



2022 IJIEMR. Personal use of this material is permitted. Permission from IJIEMR must be obtained for all other uses, in any current or future media, including reprinting/republishing this material for advertising or promotional purposes, creating new collective works, for resale or redistribution to servers or lists, or reuse of any copyrighted component of this work in other works. No Reprint should be done to this paper, all copy right is authenticated to Paper Authors

IJIEMR Transactions, online available on 16th Feb 2022. Link

[:http://www.ijiemr.org/downloads.php?vol=Volume-11&issue=ISSUE-02](http://www.ijiemr.org/downloads.php?vol=Volume-11&issue=ISSUE-02)

DOI: 10.48047/IJIEMR/V11/I02/14

Title **EFFECTIVE STRUCTURE FOR CATCHING STONES AND OTHER HEAVY BODIES IN COTTON**

Volume 11, Issue 02, Pages: 110-114

Paper Authors

Djamolov R.K. , Kholyigitov Sh.



USE THIS BARCODE TO ACCESS YOUR ONLINE PAPER

To Secure Your Paper As Per **UGC Guidelines** We Are Providing A Electronic Bar Code

EFFECTIVE STRUCTURE FOR CATCHING STONES AND OTHER HEAVY BODIES IN COTTON

Djamolov R.K. "Pakhtasanoat Ilmiy Markazi" JSC, Uzbekistan

Kholiyigitov Sh. "Pakhtasanoat Ilmiy Markazi" JSC, Uzbekistan

Abstract. The article provides an analysis of the equipment for catching stones and heavy objects in cotton. As a result, it was found that the effect of keeping the size of the stones at 10-20 mm is very low. New rock-catching equipment has been proposed and is being prepared for production testing.

Keywords. Stone, pneumatic transport, large stones, size, heavy objects, metal pieces, holding effect.

Today, in the technological process for the capture of heavy mixtures in ginneries, linear grinders installed in front of the separator of the yard pneumatic transport system are widely used.

Linear grinders have a number of advantages over other grinders, such as simplicity of construction, ease of use, low cost, and reliability. The principle of their action is based on the suspension rate of raw cotton and heavy mixtures.

Reliable movement of cotton raw material in the air pipe is carried out at a speed of air flow of 30 m / s [1], so it is necessary to reduce the air velocity in the holding chamber by 2 times to trap heavy mixtures. For this reason, the width of the chamber of the handles is 15-30% and their cross section is twice as large as the air ducts.

In addition to the difference in suspension velocities in linear handles, the difference in the recovery coefficients of raw cotton and heavy mixtures is also taken into account.

The recovery coefficient is characterized by the elastic properties of the bodies relative to the impact and, accordingly, their speed of reflection from stationary obstacles.

The recovery coefficient for stones is on average 0.7, for cotton pieces 0.2, ie the reflection rate of stones is 3.5 times higher than that of raw cotton, which ensures that the stones are separated from the raw cotton when they hit a stationary barrier.

Therefore, in linear conveyors, a change in the direction of pneumatic transport of raw cotton from horizontal to vertical is usually used, as a result of which the raw cotton and heavy mixtures move and hit the

wall of the holding chamber when the flow rotates inertially in the horizontal direction. In this case, the pieces of raw cotton are broken down and heavy mixtures are separated from them, which increases the holding efficiency, but at the same time a small part of the raw cotton enters the captured heavy mixtures.

Today, stone handles are divided into two types depending on where they are installed. The first is linear grinders. They are located on the line of the air-carrying device and are mounted up to the separator. The second is non-linear fasteners, which are installed after the separator.

Let's take a look at the most common linear ginners in ginneries.

Based on the improvement of radial stone handles, a linear stone holder of the brand 2ChTL was developed [2] (Figure 1).

The chamber width of the sieve is 470 mm when the diameter of the air tubes is 400 mm, and it works as follows: the flow of raw cotton entering the chamber decreases accordingly due to the decrease in air velocity of the carrier from its expansion. After that, the cotton wall with heavy mixtures hits the opposite wall of the chamber 3, resulting in heavy mixtures of cotton accumulating in the pocket 8 due to changes in air velocities.

The air velocity in the middle sections of the chamber depends on its flow rate as follows: 6 m³ / s flow-18 m / s, 5 m³ / s flow -15 m / s, 4 m³ / s flow - 12 m / s. That is, even when operating at high productivity with an air flow rate of 6 m³ / s, the average air velocity is 18 m / s lower than the hanging speed of a small stone weighing 1 g, which is 22 m / s as mentioned above, with more than 1 g for stones of weight the holding efficiency should be 100%, but these cases are not observed. Tests in the manufacture of this stone holder show the following results in Fig. 2

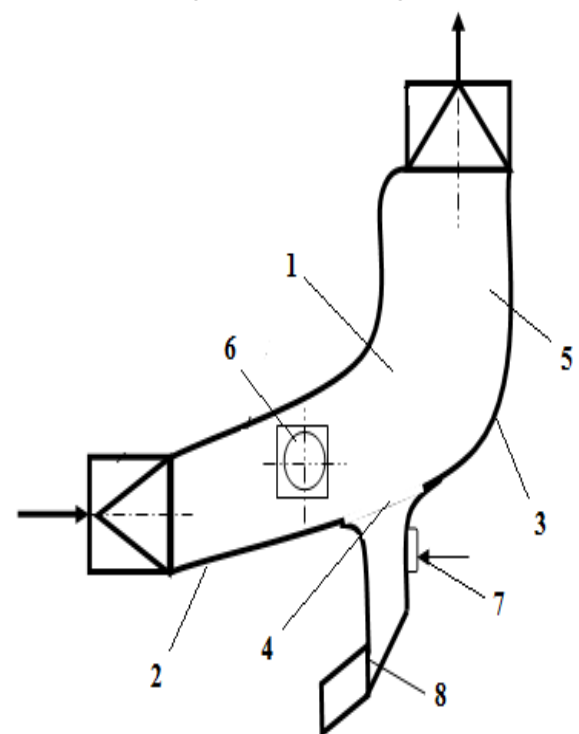

Figure 1. 2ChTL brand stone.

- 1- working chamber, 2-, 3- reference and reflective walls, 4-, 5- lower and upper

part of the chamber, 6- observation hole, 7- blinds, 8- stone-collecting pocket.

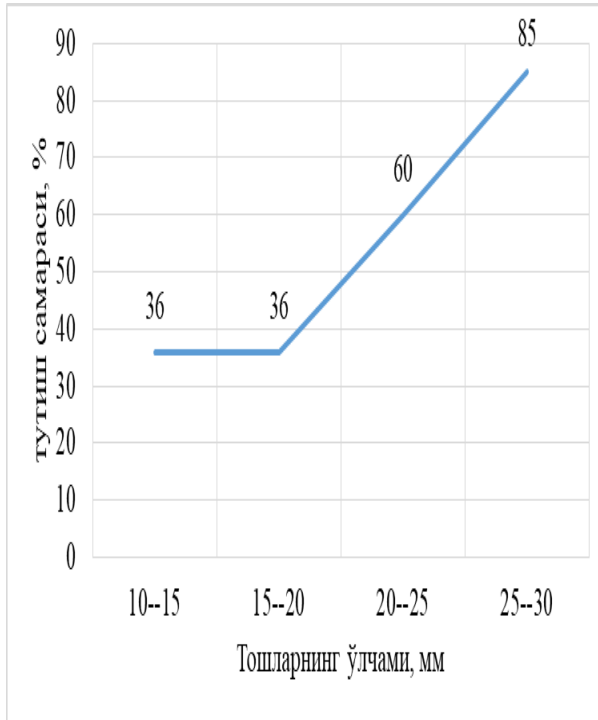

Figure 2. Influence of stone size on retention efficiency.

The graph shows that the efficiency of holding small stones in the range of 10-20 mm in the cotton content is low 36%. The passage of stones of this size leads to rapid failure of the working parts of the equipment in the technological process.

A magnetic puller was produced to capture the effect of trapping heavy compounds in cotton and the metal particles in it (Fig. 3) [3, 4, 5].

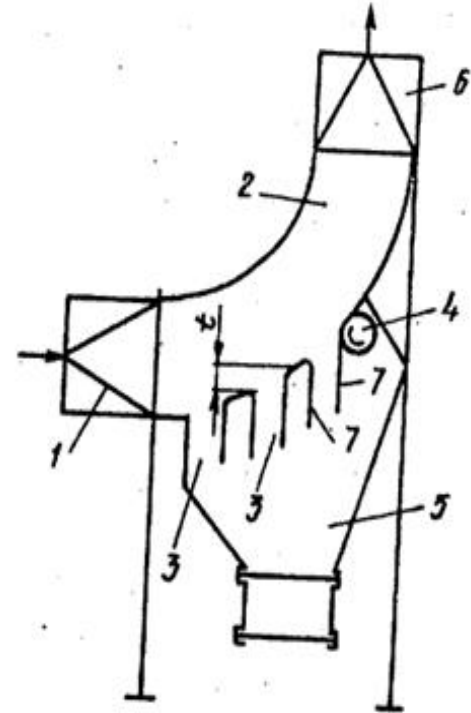

Figure 3. Multi-chamber magnetic grinder.

From the stem inlet pipe 1, the pocket chamber 3 located in the dividing arc-turned steps, the end is fitted with a magnetic rotating shaft 4, the pockets 3 are connected to the mixing hopper wall 5, and the pockets have walls 7 to prevent cotton loss from the pipe 6. R.Murodov, S.Sh.Bakhritdinov and H.K.Mamarasulov [6] has developed a design consisting of an opening and closing rod hole and a magnetic roller to trap and release heavy mixtures of cotton from the rock (fig.4).

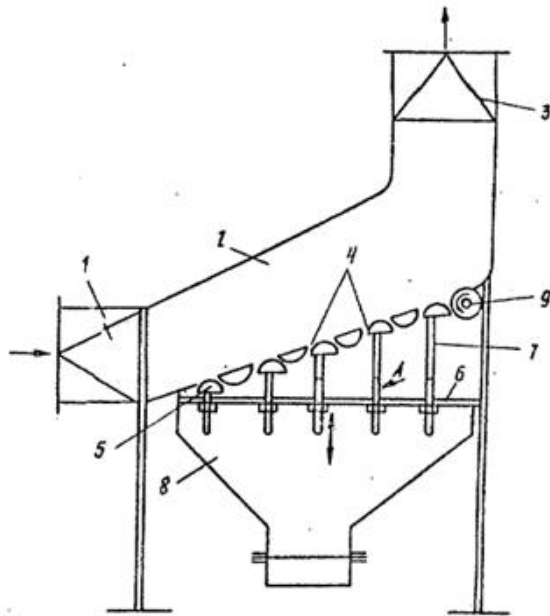

Figure 4. Heavy mixing device.

1-inlet pipe, 2-inclined aisles, 3-outlet pipes, 4-holes, 5-closing mechanisms, 6-motion guides, 7-rods, 8-assembly chambers, 9-magnetic shafts.

As can be seen from the design of the device, the times of opening the slit and transferring it to the collection chamber by holding heavy mixtures of cotton at high speed and pushing the lower rods are not taken into account. The opening mechanisms of the crack are complicated.

From the above analyzes, shortcomings such as low efficiency in catching small stones and other heavy mixtures in the manufactured trays, falling of cotton pieces with pockets in the pocket were observed, and new stone trapping equipment was developed as a result of scientific research to solve these problems.

The proposed stone holder works as follows. The raw cotton is transported by air through an inlet pipe to the separation chamber, where it is hit by a roller wall, small heavy mixtures are thrown through the cavities of the rollers and fall into the stone chamber, and as large stones lose speed in the chamber they also remain in the stone collector. Today, this stone-cutting equipment is being manufactured at "RIM Ustakhonasi" LLC at "Pakhtasanoat Scientific Center" JSC and it is planned to conduct experimental work.

List of used literature

1. Saadi F.A. Izuchenie osobennostey transportirovaniya khlopka povyshennoy vlnajnosti. Report on NIIR, topic 25 section B, TsNIIXProm, Tashkent 1968.
2. Kobuljanov K.M. Issledovanie raboty i vybor ratsionalnoy konstruksii uloviteley tyajelyx primesey dlya xlopkovoy promyshlennosti. // Diss... kan. techn. nauk. Tashkent 1960.
3. Patent SU 1390257. Ulovitel tyajelyx primesey iz xlopka-syrtsa.
4. Murodov R.M. Basics of increasing the efficiency of the transportation process in the technology of primary processing of cotton. Diss.d.t.n., Tashkent 2004.
5. Ganiev M.X. Razrabotka i issledovanie mnogokamernogo



magnetnogo ulovitelya xlopka-syrtsa.
Avt. Diss.k.t.n., T.1993.

6. Patent SU 1532607. Ulovitel
tyajelyx primesey iz xlopka-syrtsa.