



# International Journal for Innovative Engineering and Management Research

A Peer Reviewed Open Access International Journal

www.ijiemr.org

**COPY RIGHT**



**ELSEVIER**  
**SSRN**

**2020 IJIEMR.** Personal use of this material is permitted. Permission from IJIEMR must be obtained for all other uses, in any current or future media, including reprinting/republishing this material for advertising or promotional purposes, creating new collective works, for resale or redistribution to servers or lists, or reuse of any copyrighted component of this work in other works. No Reprint should be done to this paper, all copy right is authenticated to Paper Authors

IJIEMR Transactions, online available on 20th Oct 2020. Link

[:http://www.ijiemr.org/downloads.php?vol=Volume-09&issue=ISSUE-10](http://www.ijiemr.org/downloads.php?vol=Volume-09&issue=ISSUE-10)

Title: **COMPUTER AND DEEP NEURAL NETWORKS WITH DRIVERLESS MECHANICAL CAR DESIGN**

Volume 09, Issue 10, Pages: 85-100

Paper Authors

**Dr. YAGNAM NAGESH Mrs. AYANTU DANIEL GELETA Dr. B BHOOMESHWAR**



USE THIS BARCODE TO ACCESS YOUR ONLINE PAPER

To Secure Your Paper As Per **UGC Guidelines** We Are Providing A Electronic Bar Code



## COMPUTER AND DEEP NEURAL NETWORKS WITH DRIVERLESS MECHANICAL CAR DESIGN

**Dr. YAGNAM NAGESH**  
Associate Professor,  
Department of Information  
Technology,  
Mettu University  
Ethiopia, Africa  
Nageshyagnam1@gmail.com

**Mrs. AYANTU DANIEL  
GELETA**  
MSc, Dean, Faculty of  
Engineering, Department  
of Mechanical Engineering  
and Thermal Engineering,  
Mettu University Ethiopia,  
Africa, ayyuud@gmail.com

**Dr.B. BHOOMESHWAR**  
Assistant Professor,  
Department of Computer  
Science, Mettu University  
Ethiopia, Africa  
eshwarmsis@gmail.com

**ABSTRACT:** Drastic alterations from the robotics and smart controllers attracted a radical shift in automotive tech market place that contributes to your driver less vehicles during this new era. For all these autos to safely operate from the current traffic and out of disagreeable surroundings, plenty of issues in navigation, vision, and also manage really need to go solved. To embrace it forcing car technological invention into latest research and academic, we all need cost efficient and economic mechanics. Through this circumstance we call for something that might feature present motor autos and also convert men and women driver-less cars which may attain academicians and research areas. This newspaper suggests that a portable mechanical style and style which might be manufactured and squeeze into to active autos may be implemented to get a point to come up with an autonomous motor car. Traditional cars might be altered for consideration of a driver-less automobile using assorted actuators. Popularly motors function as actuators on your automation in this motor vehicle. A pneumatic technique was constructed to automate the projected purpose aside from such types of motors. The mechanical construction is a vital part of an autonomous auto or truck that's often necessarily to become shifted and intended such manners it's dynamically unwavering. The platform architecture, technical elegance, and also operation evaluation through the duration of sovereign driving together along with your platform really are more compared with two additional convolutional neural networks that we reimplemented with the entire take to have the purpose evaluation of these networks that is projected. The educated variant with the projected system is just four times greater when compared with PilotNet variant and somewhere around 250 times even larger in contrast to AlexNet variant. While elegance and dimension with this novel technique are much somewhat lower compared along with different designs that leads to decrease latency and increased rate through the duration of inference, our strategy promised that the performance, accomplishing prosperous autonomous driving together with similar effectiveness in comparison with autonomous driving together with just two additional designs. What's More, the projected deep neural network down Sized the needs for real-time inference Components Seeing computational capability, price, and also measurements.

**Keywords:** autonomous driving, camera, convolutional neural network, deep neural network, embedded systems, machine learning

## I. INTRODUCTION

The autonomous driving strategy may be put up to four cubes: detectors, realizing sub floor system, organizing sub floor system, and also control of this auto (figure 1). The auto is presently balancing the whole globe using many varied sensors installed on the vehicle. The prep sub floor system uses the output from this understanding block for behavior prep also to find both short and lasting course prep. The control module makes sure the car follows the specific road given by the groundwork sub floor system and transmits control orders to your own automobile. R&D over the world of system learning and more precisely deep learning contribute a lot of discoveries and technical applications in a variety of domains. The domain system where system learning comprises a massive effect is the fact that the automotive industry as well as the increase of autonomous vehicles. By method of example, delivery vehicles even different robots that are diverse along with robot-cars are utilized inside warehouses. The main notion of this duty was likely to create a response for autonomous driving to get you an electric system which features limited hardware components, chip power, and storage apparatus size. Possessing all those hardware limits at heart, we're planning to look for a light profound neural system, an end to end neural network system that'll undoubtedly be able to match the duty of autonomous driving in to the broker path, whilst the networks' version of good use for inference may put upon a low-performance hardware point.

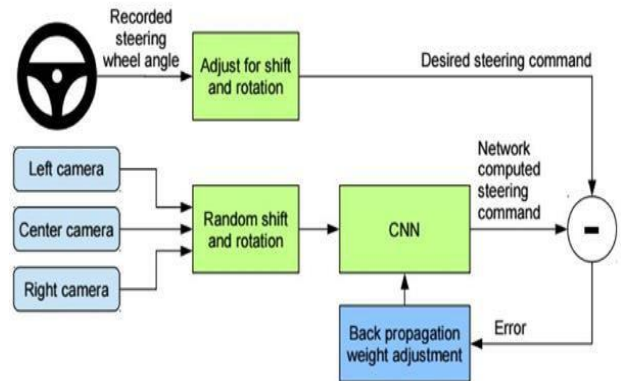

Figure 1: Block diagram of an end-to-end autonomous driving system

The curiosity about developing autonomous vehicles raises everyday with the role of achieving high degrees of protection, functionality, endurance, and delight. Driverless cars are all ideal to use in busy locations, on highways, since they facilitate the flow of these cars. Autonomous cars may also lower the chance of occurring accidents that may be brought about by other cars or from pedestrians. There are lots of research centers based round the world for growing smart systems for driverless cars like the Center for Automotive Research in Stanford University (CARS) [two]. TORCS brings an extensive community of programmers and users, plus it's the platform to get hot contests organized each year for part of numerous international conventions. The app delivers a host that implements races blending numerous cars on a number of monitors. A client module might be published by the individual supplying the activities of somebody vehicle. Our motorist called Gazelle, has

been filed into the TORCS contest coordinated by the Genetic and Evolutionary Computation Seminar in 2013 [6]. Inside this ecosystem, each vehicle is controlled with means of a procedure which could get into the present condition of the automobile within the race, composed of information concerning the trail, the vehicle, and also the opponents.

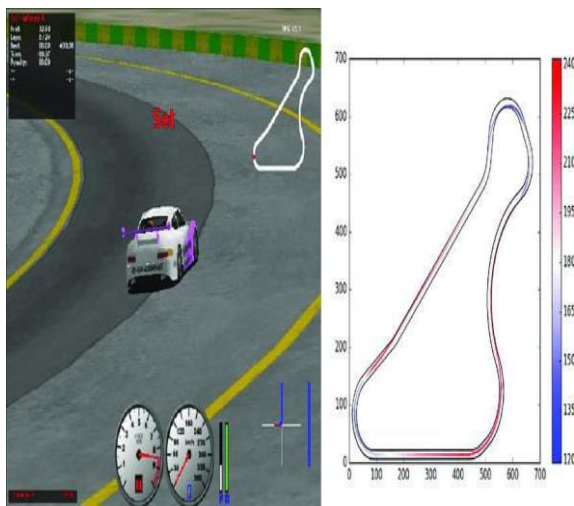

Figure 2: TORCS image during the race

The top screen displays your customer car and its own particular advice such as for example the automobile's position, the entire time which the automobile spent from the start of the race, also the ideal period that's been taken to finish a lapse, along with other dimensions. The low screen indicates the race from another angle which could highlight opponent cars when some can be found. We may even find a few statistics of this car like gear levels and also the rate of the vehicle. The job in this paper relies on the EPIC control as exhibited by Guse and Vrajitoru. Epic was filed into the GECCO 2009 contest. The Epic motorist is

predicated on two components: ascertaining the mark angle for rotation in each framework, and ascertaining the mark rate from the next framework. The control computes the target angle predicated on the totally free available space ahead. Additionally, it supplies a sharp twist discovering system that corrects the goal rate to get an impending sharp twist to preserve the car in the trail. It uses hill climbing tactics to accommodate the rate parameters into brand fresh tracks. Deployment of system learning answers into embedded hardware systems contributes to fresh improvements in two ways: creation of innovative hardware systems capable of Process information Desired for system mastering inference, and generation of innovative lighting system finding out architectures and version implementations satisfactory for low-performing components. The well-known remedies for ultimate training for autonomous driving are all fabricated mostly on account of the vehicles that is often authentic, at which in fact the apparatus learning version handy for inference has been installed about the high-speed computer that is normally bought in the rear location of the auto or human beings providers use quite profound neural networks which are computationally pricey. Yet our notion was supposed to build up a much bigger alternate, a mild profound neural system, together with similar performance throughout the whole period of autonomous driving known remedies, however using a medium computational expenditure that can empower installment in an embedded system. This milder answer



will probably undoubtedly be properly useful for robot-cars, embedded automotive processes capable of move products or execute a few very similar jobs one-of comparatively famous trajectories.

The outcomes reveal that whilst the sophistication and size of publication system are smaller compared to other versions, the J-Net Maintained the operation, achieving similar efficacy in autonomous driving. Excited about implementation within the embedded automotive stage underscores the significance of a computationally lighting option in to the DNN utilized for autonomous driving, because embedded technologies can suffer from hardware limits Because of onboard computers which aren't effective at running complex deep learning versions. The gazelle motorist also enhances the epic code these two aspects. Many approaches are seen from the literature to get track forecast with the goal of maximizing the operation. This kind of instance may be your path segmentation approach, where the trail is broken up into pieces which are categorized as predefined kinds of polygons. Afterward your control reconstructs the complete track version from such types of polygons, as exhibited. The design of this control contains simple modules which restrain gear altering, steer moves, and pedals rankings. The most essential component of this job could be that your opponent modifier. It controls both the driving behavior in scenarios where the opponent is nearby by correcting the steering control and also the braking control instantly. A more modern work poses a

driving control named AUTOPIA for its racing car contest. It supplies the complete driving structure involving six different chief tasks: gear controller, pedal controller, steering controller, stuck position manager, target rate conclusion, opponent modifier, along with learning module. The newspaper gives a very simple and a strong structure particularly for that opponent modifier with heuristic rules. Lots of learning approaches are utilized to discover the perfect path for your own car to decrease the time necessary to finish the race. An empirical learning approach with this purpose will be presented. This is a self-adaptive evolutionary strategy can be utilized to draw the parameters included with fixing the mark rate in an efficient and simple to generalize manner. This driver also lacks an opponent management system. Another control working with an evolutionary learning process is now presented. This control utilizes an easy evolutionary learning strategy to organize on the exact trail ahead to your vehicle. Recently, another learning approach has ever used hyper heuristics within a real-valued manner. This technique approaches the TORCS-based automobile system as an actual valued optimization problem also studies that the operation of unique methodologies. Included in these are a pair of heuristics and also their combination commanded by means of a range hyper-heuristic frame. The research proves that hyper-heuristics work well in the TORCS atmosphere. Artificial neural networks will also be employed as a learning platform, reputable by the computer engineering community as well as lots of

software. The control assembles a version of those paths utilizing the NNs to ascertain the trajectory of the vehicle and the mark rate. Even the NNs were trained using data recovered from an individual player. This job shows satisfying consequences of calling the trajectory on brand fresh paths nevertheless; the prospective rate is slower compared to the individual's on the very exact tracks. Through this paper we provide a novel deep neural network developed with this particular intended intent behind finishing to do away with learning for autonomous driving, also in addition known as J-Net, that'll soon be created for embedded programs. Alongside that, with the goal of aim investigation of J-Net, we speak about consequences with the re implementation's of both PilotNet and AlexNet. To start with, the publication deep Neural-network structure J-Net is fabricated; the version is beneficial and trained to get inference throughout the whole period of driving. That is achieved from probably the main reasons to have the objective evaluation of the machine structure. The utilized models are trained utilizing each one the particular same data-collection we accumulated. Obviously the trained models are extremely additionally of usage for its period autonomous driving in a simulation environment. The end result of autonomous driving with all the 3 significant neural system models are demonstrated and compared. Link between this autonomous driving is awarded as picture records of those autonomous driving within a broker class at a simulation scene, combined side this specific particular qualitative and

quantitative execution evaluation of autonomous driving variables through the duration of inference.

## **II. Related work**

Profound finding out is truly actually only a machine learning paradigm, but plus a key element of the broader set of system learning procedures determined upon learning info profiling. Representations at the same layer of some deep neural network have been voiced seeing additional, quicker representations out of preceding layers with the neural system which has been profound. The centre gradients of neural networks will soon likely probably be convolutional networks. CNNs combine about 3 architectural ideas: nearby representative locations, common weights, along with plasma or rectal Sub-sampling, which contribute about a level of scale, alter, not to mention distortion invariance. Convolutional neural networks are constructed to method info with many arrays (e.g., coloring picture, speech, sound spectrogram and additionally gains from the faculties of the signs: localized links, shared burdens, along with pooling, and the utilization of various degrees. Because of this with the, CNNs are generally employed to assessing observable eyesight. Substantial instruction for private vision has significant usage in a lot of industrial and industrial approaches and applications, such as automotive, surveillance and security, augmented fact, shrewd house software, retail automation, health, and also the entire match business, come over 3. Convolutional neural networks were clearly just one particular specific first

profound version to carry out well and so are a number of their initial approaches to fix industrial applications that are crucial. Later, Tons of optical character recognition and handwriting recognition options have been created in accordance with convolutional neural networks, even as the Latest programs of CNNs for pc vision are boundless

connections Employing artificial Info, video-to-video synthesis, along with enjoying the sport of Go, and additionally finishing finding out. The very first successful efforts of this growth of autonomous vehicles were only available from the 1950s. The earliest fully autonomous vehicles were first manufactured in 1984 and in 1987. Critical breakthrough in the sphere of autonomous vehicles has been done throughout the Defense Advanced Research Projects Agency's struggle, Grand Challenge events in 2004, 2005 and Urban Challenge at 2007 at which it was revealed that machines may independently do the intricate individual endeavor of driving. Even though there would be the prototypes of autonomous vehicles now analyzed on the normal roads, several of the challenges such as its autonomous driving aren't completely resolved yet. Present-day challenges in autonomous vehicles development have been detector combination, higher-level preparation decisions, an ultimate learning for autonomous driving, and reinforcement learning for autonomous driving and individual machine interaction. A methodical comparison of profound learning architectures utilized for autonomous vehicles has been extended a brief breakdown of detectors and sensor combination in autonomous vehicles will be presented.

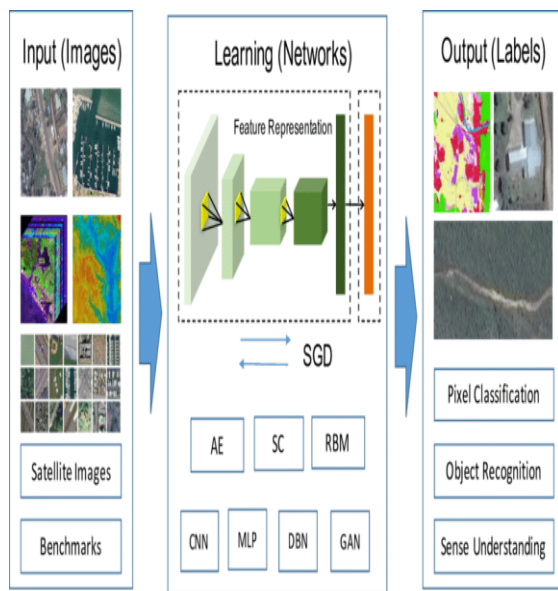

Figure 3: Flow of deep learning development

Significant participation into the maturation of both convolution neural networks together with deep studying architectures is given by Picture Web Large Scale visible Presence obstacle. Within a long time, the architectures which got this competition reflect the advanced of neural networks along with deep studying, having a structure block and also inspiration to find solutions that are fresh. A number of these novel discoveries in deep learning happen to be automatic system learning, coaching deep

### III. Autonomous Driving System

In your approach we've used wind to get rid of learning how to obtain an autonomous driving plan. Input within our autonomous driving plan was the image, raw pixels, and also the output signal has been restriction of this auto, the tire. The concluding learning was implemented through which the device will find to command a car only based on an input by the camera through the duration of real-time inference.

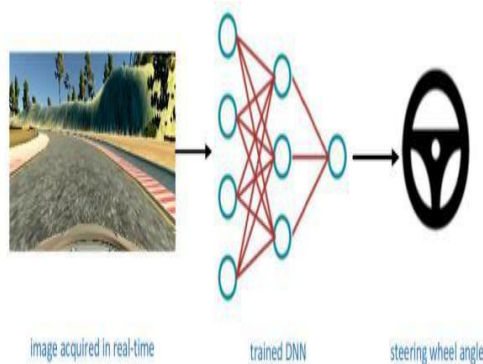

Figure 4: Real time autonomous driving picture obtained by the camera is fed into the skilled deep neural network version

Primarily, like an easy means to find the knowledge which is going to undoubtedly probably soon likely be properly used for training which the limit to get rid of DNN variant, a single driver was driving the automobile along with documenting the images together side steering measurements. At the event the simulator environment for autonomous driving has been utilized, the auto has been pushed into manual (training) manner with one driver coping using a mouse, mouse or even joystick, in addition to the data group has been mechanically accumulated. Data acquired throughout manual driving manner were camera

graphics and also the steering maxims each framework. The graphics were used while the feature category, and also the steering dimensions as the tag collection. The pace with the automobile was repaired as an effect of ease. Data accumulated by applying this procedure were of usage for instructing the neural network which may find outside to use a car predicated on the input data, with no more human discussion. This system is predicted behavior cloning. Second, the neural system for autonomous driving was trained employing this distinct specific data set to predict the scooter. Obviously, the trained version was of good use for inference, a legitimate time autonomous driving at the same simulation setting. The metrics of driving the rep path has come to be the vehicle remains traveling at all times throughout autonomous driving. A block arrangement using this particular autonomous driving frame that we employed

### IV. DESIGN

**Pneumatic Circuit:** Pneumatic circuit contains 3 cells such as clutch, brake and accelerator respectively shown in center. Cylinders are commanded by way of this 5/3 valve. The valves may be handled with a miniature get a grip on. From actuating the valves that your tanks may proceed outside and 2 and undoubtedly will be flipped into still in desirable areas. These things may be triggered individually or with each other reliant through to the prerequisite of their vehicle or automobile. Solenoid valves are employed and the input signal is given as an effect of a miniature controller.



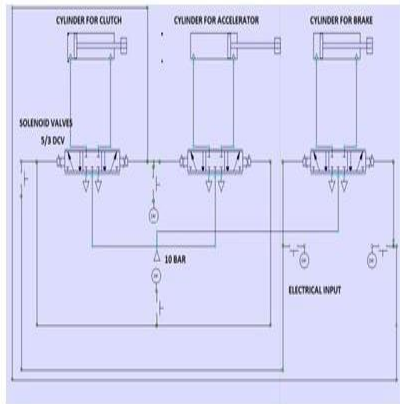

Figure 5: Pneumatic Circuit

**Cad Model:** The cad drawing was designed to create the job of the cylinders, the mountings over the framework and the arrangement of this framework. There are 3 tanks at the version each to get a framework consists of and mended onto the automobile and also the electrons have been mounted on it shown in Fig. (6).

Fig. 6: accelerator, brake and clutch respectively drawn in CAD.

The pneumatic cylinders are connected into this the suggested cad version is fabricated in the Car and can be analyzed with Pneumatic inputs in Fig. (7) Management control valves and are subsequently joined to the air reservoir.



Figure 7: Fabricated Parts

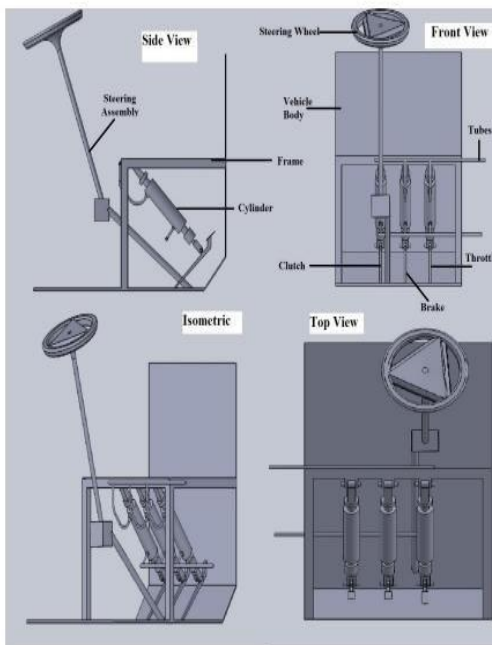

## V. STEERING SYSTEM

The cad version was created as a way to create and put the stepper motor with all the apparatus push the steering gathering. The powered gear is adjusted for the Cells like clutch, brake and accelerator respectively as exhibited at center disease. Cylinders are commanded with this 5/3 valve. The valves may be handled with a miniature controller. From actuating the valves that your tanks could proceed to and out of and undoubtedly will undoubtedly probably likely soon are flipped into even now in desirable areas. These points may be triggered individually

or using each other reliant on the inside of their vehicle or automobile. Solenoid valves are used and also that the input signal is provided as a Effect of the micro

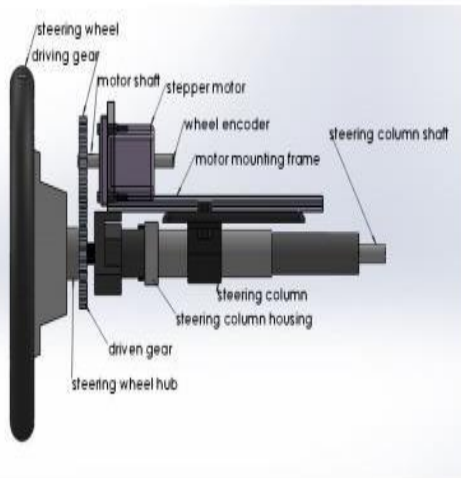

Figure 8: cad model

## VI. The J-Net Architecture

On the center to this very initial convolution that the dimensions has been  $320 \times 65 \times 3$ , then later We picked three normalization and scattering with the raw image we subsequently executed that the kernel size of  $5 \times 5$  with 16 feature maps. The main reason behind improved features extraction, so we've chosen three convolutional to become Trainable parameters after primary convolutional coat has been 1 2 16. Adding more concealed layers into a deep neural system helps with parameters efficacy. Alongside afterward, profound neural networks useful for graphics possess become efficient, since graphics possess a propensity for a hierarchical arrangement that profound models naturally catch. The reduced layers

of neural networks catch simple features like lines or borders. Further layers extract rougher features like geometric contours; in addition to the layers are yanking items. Since the aim of this job was developed to induce an automobile within a representative class, the features essential to eventually become pulled would be different goods; rather they would be the simplest capabilities or geometric contours. As a consequence of this, because of the final variant, we've chosen three convolutional layers followed closely with one sided coating and 2 fully combined layers, as could be discussed at length at the additional text.

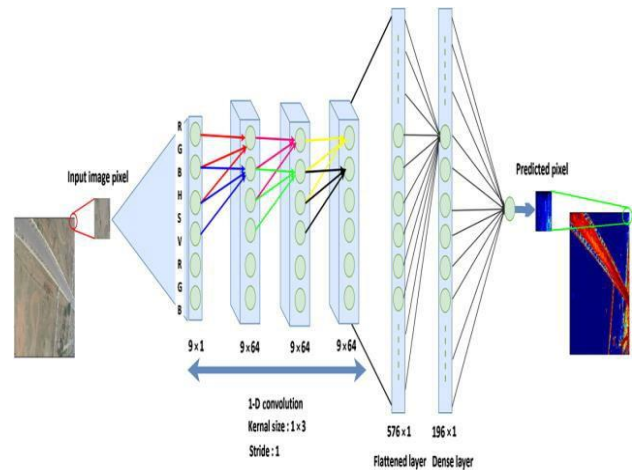

Figure 9: Architecture of end-to-end DNN, J-Net, used for autonomous driving

This lowers the opportunity for experiencing increased over fitting. Second, maximum pooling frequently yields a far more accurate variant. On the reverse side, considering that the convolutions that moved under run at the decrease pace, the version grows quicker to calculate. In addition, introducing a brand fresh layer because it provides greater



hyperparameters to song, only like as the pooling set measurements along with this rotational pace. Inside our version we now picked Max-pooling with size  $2 \times 2$  which off-the-shelf samples every thickness slit where as in two, together both height and width, shedding 75 percent in these types of activations. The thickness measurement stayed unchanged. In cases like this, we reduce the quantity of trainable network parameters, even although the feature map wasn't interrupting appreciably. Next convolution jacket, the particular indistinguishable Max-pooling temporarily following the most important convolution has been executed. The second kernel size has been  $5 \times 5$  using 64 features map that resulted in the whole selection of trainable parameters of 18,496 and after the coming convolution. Even once we're increasing the agent testing process, those nodes need to be associated with this only closing node. The flattened layer failed to contain of things such as parameters which can be not brand new, but alternatively, just rectified the comprised within inch measurement. Obviously the specific past layers of the fabricated DNN established two fully connected layers, so hence the original using ten output as well as the 2nd without a further than one output node for its steering prediction. As a way to get an objective performance analysis of this system, we re-implemented three dimensional system elements: LeNet-5, AlexNet and PilotNet with little alterations as a way to be capable of assist entire learning for autonomous driving. The idea will be always to have desire to test of this version, J-Net, in

comparison to famous networking architectures. As a consequence of this, all utilized versions were trained together employing each one the particular same data-collection we developed, which could be explained and analyzed within the simulator featuring all of the current special ailments. Regrettably, autonomous driving with all a whole LeNet-5 variant wasn't successful; so the auto was unable to adhere to the street, ergo this version was deducted out of further scrutiny. Inference with AlexNet and PilotNet had been powerful at autonomous driving throughout the whole track. As we desired to attain a light remedy, in addition convolution is in fact merely an extremely high priced operation that adds a substantial range of these machine nodes, in addition to the weights attached with these down nodes sampling has been needed. 1 alternative for this certain issue is using of striding throughout convolution, to alter the filters with lots of the few pixels each single time and scale down the part map measurement. But down this sampling of this film might cause the scarcity of this few of crucial capacities since it eradicates an entirely fantastic piece of information. The 2nd remedy to sampling an image is your rotational functioning. Rather than by passing you generally in two convolutions, we had just a very small stride in conjunction with all of the convolutions from a nearby and united them. Being a method to diminish size inside their own thick neural network layers, we then afterward currently implemented the maximum vented operation after every convolutional stratum. In extreme pooling

jacket, only about every single everything of this feature map is more conducive with only a very small little space around there and probably the vast majority of every of the answers round its ascertained.

individuals witnessed two overlapping levels. The debut of three dimensional pooling levels can slightly lessen the range of pixels onto a coming convolutions, in order once we needed a much a lot more compact input in 1 measurement, there might be inadequate pixels numerous convolutional levels utilizing preliminary kernels. Like a method to simplify and change the system of their goals, we explored the initial 2 liter layers in the exceptional strategy; add inch max pooling coating following having a forward convolutional coating, combined side 384 characteristics, overly until past convolutional coating, also using 256 characteristics. Produced in observable graphics, in amongst very initially structure and also our r e functioning, decided the total variety of parameters. In our instance we'd a decrease degree of trainable parameters compared toad been outside from this very first structure. The last major distinction between initial structure and our implementation of AlexNet can function as preceding coat. From the original AlexNet there were inch, 000 nodes while the outcome signal, according to ImageNet competition there clearly was 1, 000 paths. Within the app, just a single output node was desired: steering forecast for this automobile control. PilotNet, in addition known as NVIDIA CNN that is engineered by researchers in NVIDIA Corporation, can function as deep neural network for eventual autonomous driving," built from their motivation to directly boost the DARPA Autonomous motor vehicle system for autonomous driving. PilotNet comes with a

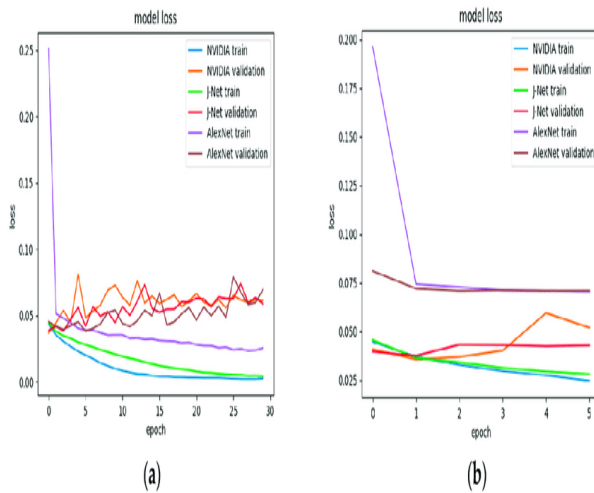

Figure 10: Replies of neural network architectures we used and implemented for finishing autonomous driving: (a) AlexNet; (b) PilotNet; (c) J-Net.

**Design Details for AlexNet and PilotNet Re-Implementations:** During our job, the AlexNet structure was re-implemented and accommodated using the purpose of learning for autonomous driving. From the exact first arrangement with all the AlexNet, then it's likely to locate two parallel pipelines of computing. As we'd enough components parts to productively coach AlexNet with only one GPU, on your execution of AlexNet we mimicked that the appearance and also used that a flow of convolutions, with a combined multitude of filters suggested with all the true remedy. Enormous gap in entered inside our r e functioning of AlexNet, consequently

normalization coating, followed carefully with 5 convolutional layers, then followed by four entirely attached levels. Tremendous gap amongst preliminary PilotNet arrangement and our PilotNet implementation might possibly be the input with the technique, which caused the little differentiation, is due to these layers along with assortment of trainable parameters. Get of those keeping convolutional, flattened, together side fully-connected levels was indistinguishable, together with most of the current specific selection of attributes alterations to the convolutional levels. Due to the fact the size with the original enter the PilotNet was not exactly enjoy the input signal, there's gap in the sum of trainable parameters. If there clearly was PilotNet, at the situations thirty epochs and 6 epochs it can possibly be famous there clearly was just really actually a summit of childbirth reduction in the fifth epoch, an amazing gap among childbirth and training reduction that indicated the necessity to apply an early stopping procedure also to opt for 4 epochs for coaching which the PilotNet. Due to this version across the autonomous forcing confirmed your choice, showing the PilotNet awarded the exact perfect driving operation since it absolutely was trained making use of 4 epochs. About the flip side, the alternative of 6 epochs for a J-Net variant education has become the philosophical alternative. For coaching the J-Net variation, the exploration revealed the hair had been gained with an inferior number of epochs, but that quantity can change among 4 and 10 epochs with equivalent effects. We chose 6 epochs, which furnished successful autonomous

driving throughout the identification with this particular version. All utilized hyperparameter pruning processes led at enhance both the implementation and teaching of those programs in addition to the prosperous completion of the endeavor of autonomous driving in the consultant course in a simulator atmosphere. As it was predicted, predicated upon the whole number of trainable parameters explained at the prior portion, the optimal/optimally variant was J-Net with only 1.8 M B.

## **VII. Results and Discussions**

The projected deep Neural-network J-Net was compared with AlexNet together side PilotNet, that have been employed as an effective way to run a target performance test with the publication design. The sorts of three machine architectures were executed, trained together with the particular same data group, and additionally trained models were of usage for inference from the simulator to acquire autonomous driving. The system structure, the relations between nodes, instantly determines the computational power with the method. One among the vital differences between ordinary neural networks and traditional artificial neural networks might possibly be the links between the nerves aren't fully connected. Here by that the specific organization with the profound neural network and also the particular characterization of the computations in filter elements influence determine exactly the system sophistication. With reference into some design model which isn't trained. In Table 2, the two layers and moreover the

wide collections of the aforementioned parameters of the neural networks have been displayed. The machine released in this paper, J-Net, had approximately 50 percent the trainable parameters in comparison to PilotNet, along with also approximately 280 times less than AlexNet. Along with the, throughout the practice, we calculated lots of floating point surgeries for every single version which have been expected, determined by the amount of parameters: 42.45 million multiplication and the exact same number of improvement operations for its AlexNet, 347.82 million operations for multiplication as well as also to its inclusion for its PilotNet, also about 150.84 million operations for its multiplication and also to its inclusion for that J-Net.

Table 2: Number of trainable parameters calculated based on input image size.

Layers and parameters	AlexNet	PilotNet	J-Net
Convolutional	5	5	3
Flatten	1	1	1
Dense	3	4	2
Total number of trainable parameters *	42,452,305	348,219	150,965
Multiplication	42.45 m	347.82 k	150.84 k
Addition	42.45 m	347.82 k	150.84 k

We compared the size of these coached models: The AlexNet variation needed a memory size to get 509.5 MB, PilotNet 4.2 M B, also J-Net only 1.8 M B. All models were trained together using all of the specific same data collection, reduction attribute, also optimizer. The number of epochs used for its clinic of each variant has been different as a consequence of interruptions in variant over fitting which is going to be indicated by the ratio of training and identification loss attained through the duration of the shape training. As the machine arrangement itself, system's variations contour, measurements, and connections between layers, so directly influence how the computational expenditure, what size the trained variant has influence in the inference being a consequence of memory restrictions of their embedded hardware components.



Figure 11: Relative deviation from the center of the trajectory per one full lap.

Statistical test of autonomous driving may be shown for the whole period of these histograms. This investigation is considerably more significant for long-term evaluations. Histogram of all J-Net driving was presented; so in it was demonstrated

that the J-Net receives the littlest similarity contrary to the curves, even as the oscillations in to the most critical market of these trajectories are the largest. For the internet that the oscillations were light in comparison to the other networks such as autonomous driving, nonetheless this version had significant oscillations in curves left and directly, only because they are viewed, in that to locate both tips occasional happenings had comparative deviation from the middle of those trajectories at nearly completely. Histogram of the relative deviation from the heart with this trajectory Demonstrates utilizing AlexNet for sovereign driving had probably the very secure driving experience, collectively with all the smallest oscillations from the centre of these trajectories. On the opposing hand, there is an episode of irregular high stalks from the centre of the trajectories within a curve administration. But this variation was allowed constraints, the automobile failed to turn out of this route, which had been the standard we defined for powerful autonomous driving.

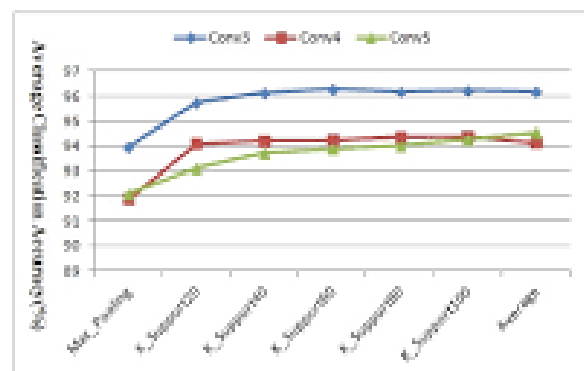
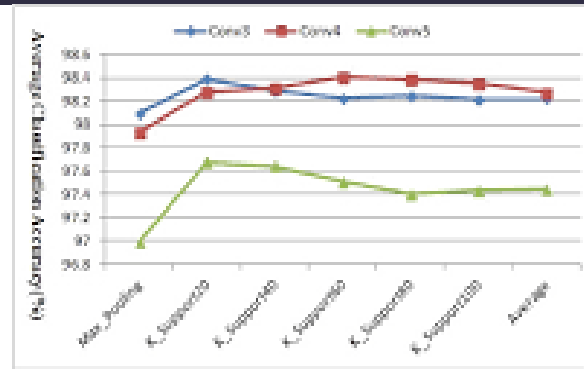

Figure 12: Histograms of deviation from the center of the trajectory per one full lap of autonomous driving.

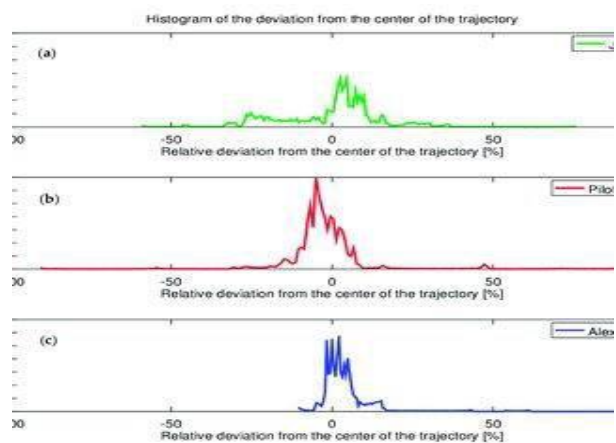

Figure 13: Histograms of deviation from the center of the trajectory per one full lap of autonomous driving. (a) J-Net; (b) Pilot Net; (c) AlexNet.

## **VIII. Conclusion**

Nonetheless, the more industrial application frequently includes machine learning solutions which may be deployed computationally smaller and much more reasonably expensive memory requiring embedded apps which have low measurements and also cost. Deploying machine-learning components on a low-performing hardware stage indicates using a somewhat very affordable version viewing computational memory and power gear that could potentially be done by careful design using a neural network version structure. The aim of this job will understand strong autonomous driving coping using a light profound neural system that's acceptable for inference and installation at an embedded electrical stage. Bearing this in mind we've assembled and executed J-Net, a profound convolutional neural system capable of successfully conduct job of autonomous driving by way of a representative class, with the majority of the present computational capacity for employing this system function as smallest one of additional well-known solutions which were researched in this newspaper. The main involvement of suggested work can be the publication solution that's computationally effective being due to relatively mild structure. The complexity of the algorithm is set by the large choice of surgeries in one iteration our profound neural system indicates similar behavioral results achieved using fewer surgeries when compared with other neural networks researched within this paper. The prospective limit of J-Net might

serve as insufficient generalization as a result of the complex-use case scenarios. Alongside that, this version is trained with raw camera pictures and also steering measurements per each framework; at which whilst the pace with the automobile is known to be considered a frequent as an effect of ease. This finishes from the limit for the whole period of autonomous driving about this rate as the steady speed is indicated. But it may have the capacity to coach you are J-Net to predict the sum of the car or truck. The exact same system of calling steering may possibly be suitably used, which might potentially wind in creating simultaneous forecasts for speed and steering dependent on the input signal at real time a mechanical platform is made and designed to restrain mechanical components such as accelerator, steering system, steering and brakes of these automobile. The machine will continue to work centered on our inputs out of this vision module whilst still within your automobile. The actuation has been finished with no delay and mistakes, and also the commanding of these procedures. The engine drive may readily rotate the steering utilizing minimal delay. Automation for this particular apparatus procedure is always to be performed out at the very long haul to conduct the vehicle in high rates; it's going to undoubtedly be performed with stepper motors or by simply utilizing unmanned tanks.

## **IX. Future Enhancement**

The upcoming work comprises the setup with the introduced network in an embedded electric platform using small hardware



components, very-low processor electrical electricity, and also surprisingly lower memory measurements. The possible final utilization cases because of the own presented conclude to get rid of schooling platform happen to be robot-cars in warehouses and shipping cars. Utilizing mild DNN alternate, like the one offered inside this newspaper, empowers installation on embedded cell platforms employing compacted components, surprisingly low expensive size, and also size, so that'll be essential for industrial programs.

## **X. References**

1. Haffner P. "Gradient-Based Learning Applied to Document Recognition".
2. Platt J.C. "Best practices for convolutional neural networks applied to visual document analysis".
3. Mollura D., Summers R. "Deep Convolutional Neural Networks for Computer-Aided Detection": CNN Architectures, Dataset Characteristics and Transfer Learning.
4. Efros A.A. Context Encoders: "Feature learning by in painting".
5. Li F.-F. "Large scale video classification with CNN".
6. Chi J., "Prediction of arctic sea ice concentration using a fully data driven deep neural network".
7. Berg A.C. "Imagenet large scale visual recognition challenge".
8. Zisserman A. "Very deep convolutional networks for large-scale image recognition".
9. Sun J. "Deep residual learning for image recognition".
10. Y. Renet: "A recurrent neural network based alternative to convolutional networks".
11. Le Q.V. "Learning Transferable Architectures for Scalable Image Recognition".
12. Fidler S. "Efficient interactive annotation of segmentation datasets with polygon-RNN++".
13. Catanzaro B. "Video-to-video synthesis".
14. Zhang J., et al. "End to end learning for self-driving cars".
15. Muller U. "Explaining how a deep neural network trained with end-to-end learning steers a car".
16. Anbumani S. "Learning end-to-end autonomous driving using guided auxiliary supervision".
17. Wang C. "LiDAR-video driving dataset: learning driving policies effectively".
18. Lee D.-J. "An End-To-End Deep Reinforcement Learning-Based Intelligent Agent Capable Of Autonomous Exploration in Unknown Environments".
19. Hinton G.E. "Imagenet classification with deep convolutional neural networks".
20. Udacity, Inc. "Self-Driving Car Simulator".
21. Courville A. "Deep Learning", the MIT Press
22. Aggarwal C.C. "Neural Networks and Deep Learning.
24. Chollet F, "Deep Learning with Python manning publications".
24. Barto A.G. "Reinforcement Learning".
25. Jackel L.D. "Back propagation applied to handwritten zip code recognition".
26. P. Goodman, "Advantages and disadvantages of driverless cars," Nov. 22 2016.
27. A. A. Jose, C. A. S. Pillai et al., "A novel approach for scheduling and routing of the self guided vehicles in mesh topology using velocity control and alternate path techniques," 2011.
28. J. M. Anderson, "Self-driving vehicles offer potential benefits, policy challenges for lawmakers," Jan. 6 2014.
- 29 R. K. Megalingam, V. Mohan, A. Mohanan, P. Leons, and R. Shooja, "Wireless sensor network for vehicle speed monitoring and traffic routing system".