



COPY RIGHT

2017 IJIEMR. Personal use of this material is permitted. Permission from IJIEMR must be obtained for all other uses, in any current or future media, including reprinting/republishing this material for advertising or promotional purposes, creating new collective works, for resale or redistribution to servers or lists, or reuse of any copyrighted component of this work in other works. No Reprint should be done to this paper, all copy right is authenticated to Paper Authors

IJIEMR Transactions, online available on 1st Sept 2017. Link

[:http://www.ijiemr.org/downloads.php?vol=Volume-6&issue=ISSUE-7](http://www.ijiemr.org/downloads.php?vol=Volume-6&issue=ISSUE-7)

Title: **SERIES VOLTAGE COMPENSATOR FOR REDUCTION OF DC-LINK CAPACITANCE IN GRID- TIE SOLAR INVERTER**

Volume 06, Issue 07, Pages: 657 – 662.

Paper Authors

SHAIK JEELANI., D S MUNIRUNNISA

SVR Engineering College



USE THIS BARCODE TO ACCESS YOUR ONLINE PAPER

To Secure Your Paper As Per **UGC Guidelines** We Are Providing A Electronic Bar Code

SERIES VOLTAGE COMPENSATOR FOR REDUCTION OF DC-LINK CAPACITANCE IN GRID-TIE SOLAR INVERTER

¹SHAIK JEELANI., ²D S MUNIRUNNISA

¹Pg Scholor, SVR Engineering College

²Assistant Professor, SVR Engineering College

ABSTRACT: A grid-tie solar inverter with a series voltage compensator for reducing the high-voltage dc-link capacitance is presented. The overall required energy storage of the dc-link, formed by a reduced value of dc-link capacitor and the voltage compensator, is reduced, allowing the replacement of popularly used electrolytic capacitors with alternatives of longer lifetime, like power film capacitors, or extending the system lifetime even if there is a significant reduction in the capacitance of electrolytic capacitors due to the aging effect. As the required energy storage of the dc link, formed by a reduced value of the dc-link capacitor and the compensator. And then software simulation is carried out. **KEYWORDS:** dc –link capacitance, dc-ac converter system, grid tie solar inverters, photovoltaic systems reliability, capacitance reduction.

I. INTRODUCTION A capacitor supported system consists of multiple power converters interconnected by a dc link. The dc-link voltage is maintained by a capacitor bank that absorbs instantaneous power difference between the input source and output load, minimizing voltage variation on the dc link, and providing sufficient energy during the hold-up time of the system. Among different types of capacitor, aluminum electrolytic capacitors (E-Caps) are the most popular choice because of their high volumetric efficiency and low cost. However, they suffer from the drawbacks of high equivalent series resistance (ESR); low ripple current capability; bottleneck of the voltage rating; relatively short lifetime compared to other components.[1]; and considerable maintenance work. In today's eco-conscious world, the rapid pace of

advancement in smart grid technology has a positive effect on the electricity industry reforms. The goal is to use smarter control of distributed energy sources combined with intelligent demand side management to improve the overall efficiency and reliability of the power grid. When looking at a power converter, it is clear that a great part of the volume is dedicated to dc capacitors. The reduction of the dc-link capacitor size [2] and of the dc-link voltage fluctuation is an important issue in the case of unidirectional power switch three-phase two-level converters and multilevel converters. A storage capacitor with large capacitance is required to balance the instantaneous power difference between the pulsating input power and the constant output power. A large capacitance is needed, and therefore, an electrolytic capacitor is often used as the

storage capacitor. However, it is known that due to its liquid electrolyte, the lifetime of electrolytic capacitor is very limited. At this point, the output capacitor can be an obstacle to design an ac–dc power supply for long-lifetime loads [3]. for example, ac–dc drivers for high-brightness LEDs or long-lifetime power supplies, for example, non accessible or remote equipment. Therefore, the power supply manufacturers are looking for reducing this capacitance in order to avoid the use of an electronic capacitor. According to this idea, nowadays, many of them offer lifetime warranty in the range of 5 to 10 years of lifetime. Typical power conditioning systems consist of multiple switching-mode power converters. In order to provide high degree of controllability and flexibility of power flow, the electrical energy generated by renewable energy source is converted into dc power while the one delivered to the other part of the system or load is converted from the dc power. Thus, power converters are all interconnected through a dc link. To ensure a stable operation of the power conditioning system, the dc-link voltage is stabilized by a capacitor bank, which is sometimes the dominant part in terms of the physical volume and cost. Among the different types of capacitors, aluminum electrolytic capacitors are a popular choice for the capacitor bank, due to their high capacitances in a small form factor. The compensator processes an ac power, which is double of the line frequency. Thus, many electrical models of electrolytic capacitors were studied to find a signature of their failure. In the series model, equivalent series

resistance (ESR) gives image of power loss inside the capacitor. The increase of ESR is the best indicator of fault for capacitors, and can be deduced from the ripple voltage. However, all the series model components (capacitance, resistance, and inductance) are varying against [4] frequency. thus the system stability. In the existing system the shunt voltage compensator are used to control the voltage in the system. But the shunt voltage compensator increases the dc-link capacitance value which in turn increases the cost of the capacitor. Thus the paper contained the series voltage compensator. By using the series voltage compensator we can control both the voltage and current. We are using the technique of MPPT to efficiently utilize the photovoltaic energy and reduce the power losses. During the operation of MPPT, we can control the driver circuit which in turn controls the pulse given to the MOSFETS. The feedback of the power availability in the load is also measured concurrently and the readings are obtained. Based on the values obtained we can give the pulses to the compensator, based on it the compensator will act accordingly. We can also control the boost converter in the circuit also by using the measured value.

II. BLOCK DIAGRAM

The Blok Diagram of Grid –Tie solar inverter by using series voltage compensator is shown in fig.1 In the Fig.1 DC supply is supplied from a Photo Voltaic Solar cell module. There are three modes of operation in the circuit. In the first mode, When

obtained energy from the solar panel is sufficient for the grid to operate the boost converter will not perform any operation. It will give the obtained energy directly to the dc link capacitance and the capacitor will filter the ripples in the input and it will be given to the inverter. Inverter will convert the obtained dc to ac and it will be connected to the grid

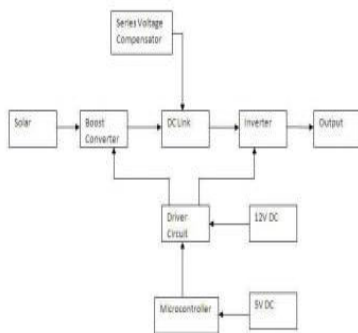

Fig.1 Block diagram of grid tie solar inverter by using series voltage compensator.

In the second mode, the obtained energy is low compared to the grid, In this condition the boost converter will act accordingly and it will boost the obtained voltage equal to the grid voltage then the dc link capacitance, inverter will operate accordingly. Then obtained energy will be given to the grid. In the third mode, the obtained energy will be more than the grid voltage. In this stage the series voltage compensator will act. The series voltage compensator will store the excessive amount of voltage in the battery connected with it, and then the remaining required voltage will be given to the grid. When the grid voltage is less the series voltage compensator will act and give the

required amount of energy to the grid. Thus excessive amount of energy is not wasted and utilized when required by the grid. The pulses required by the boost converter and the inverters are given by the driver circuits. The driver circuits are controlled by the microcontrollers. Microcontrollers are programmed accordingly to monitor the current state of the grid and to give the signal accordingly to the driver circuits. The driver circuits will get the signals from the microcontrollers and convert those signals to pulses and give it to the MOSFETS in the converter and the inverter in the circuit. The supplies for the driver circuit and the microcontrollers are 5volt and 12 volts respectively. The return flow of current to the boost converter is prevented by using the diode connected to it.

III. PROPOSED CIRCUIT DIAGRAM

Fig2. Shows the proposed circuit for grid-tie solar inverter by using series voltage compensator. It mainly consists of solar string, boost converter, dc-ac converter, series voltage compensator and the filters in the circuit. Initially the solar panels will produce energy that will be given to the capacitor C_p , it will filter the input voltage and will be given to the boost converter. In normal condition the energy produced is equal to the energy required obtained energy will be directly given to the grid by dc to ac converters without the requirement of series voltage compensator and boost converts. Based on the input the boost converter will work in two cases. The current flow to the source is prevented by the diode D5

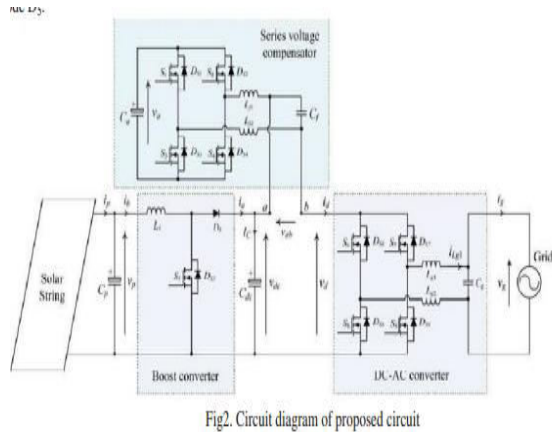

Fig2. Circuit diagram of proposed circuit

Case1 ($V_p > V_g$): In the Second case, the input voltage is higher than the required voltage, during this stage series voltage compensator will operate. The series voltage compensator is having 4 MOSFETS Ds_1 , Ds_2 , Ds_3 , Ds_4 . The switches Ds_2 and Ds_3 will operate and the voltage higher than the required voltage will be stored in the capacitor C_a . The remaining required power will be given to the grid. The energy stored in the battery will be used when the load requirement is high and the energy produced by the panel is low.

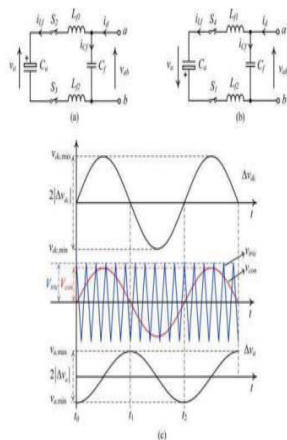

Fig 3. Ripple voltage on the input capacitor C_a in the compensator. (a) Operation when S_2 and S_3 are on. (b) Operation when S_1 and S_4 are on. (c) SPWM and the ripple voltage generated across C_a .

Figure 3 (a), (b) shows how the capacitor C_a works accordingly to the required cases.

Also the figure represents the operating modes of the compensator using a full bridge. When S_2 and S_3 are on, the capacitor C_a is charged by the load current i_d . Conversely, when S_1 and S_4 are on, the capacitor C_a is discharged by i_d . Fig. 2(c) shows the waveforms of the dc-link capacitor voltage v_{dc} , modulating signal v_m , triangular carrier signal v_{tric} , and the voltage across C_a , v_a .

IV. SIMULATION RESULT ANALYSIS

The system was simulated using Matlab's simulink software with the power system tool box. With this software we simulate and test the proposed circuit. The simulink model is shown in Figure. The simulation of reduction of capacitance in grid tie solar inverter using series voltage compensator is obtained and the performance curves are plotted. The output curves of the simulation given in the figure 4 are given below. The MPPT present in the simulation do all the necessary processes to give pulses to all the MOSFETS through the microcontrollers and driver circuit

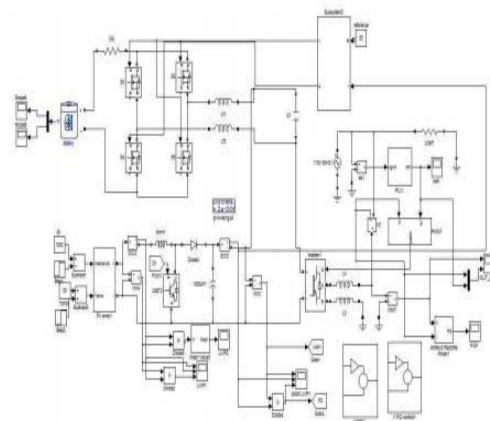

Fig-4- simulation circuit for grid tie solar inverter using series voltage compensator

V. OUTPUT WAVEFORMS

The waveforms for the simulation circuit are given below. The output wave form contains the outputs of battery voltage, booster voltage, current, and power. Inverter output voltage and current. Here the battery voltage is direct current. Also the booster voltage is the same dc. But the inverter converts the dc to ac that's why the output wave form of the inverter contains the ac output wave form.

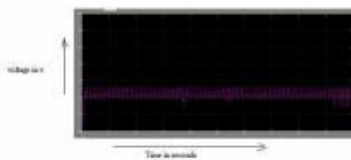

Fig- 5 .Battery voltage waveform

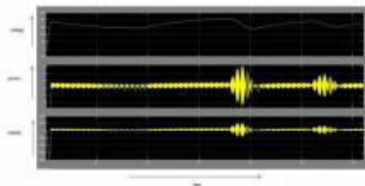

Fig-6 .Booster voltage, power and current

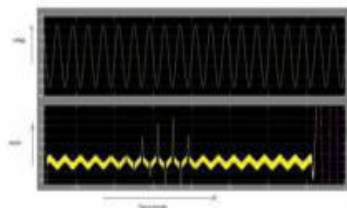

Fig-7.Inverter voltage and current waveform

VI. CONCLUSION

This paper done the study that a series voltage compensator can be used to reduce the dc-link capacitance. Such concept is applied to a grid-tie solar inverter. The steady-state power managed by the series voltage compensator is relatively constant in the ac-dc-dc system. While the solar inverter has to process time-varying ac power. Thus, interactions among the front-stage boost converter, compensator, and output dc-ac converter, have been discussed. The output of the boost converter, compensator and inverter are analyzed. From the results it is shown that we can control the flow effectively better than the shunt voltage compensator in the series voltage compensators. As well as, we can reduce the dc link capacitance value, which in turn reduce the cost of the whole system. Thus the series voltage compensator will reduce the cost of the whole system and reduce the value of dc-link capacitance and also reduces the size of the capacitor by reducing the value of capacitance.

REFERENCES

1. H. Wang, H. Chung, and W. Liu, "Use of a series voltage compensator for reduction of the DC-link capacitance in a capacitor-supported system," *IEEE Trans. Power Electron*, vol. 29, no. 3, pp. 1163–1175, Mar. 2014.
2. I. S. Freitas, C. B. Jacobina, and E. C. Santos Jr., "Single-phase to single phase full-bridge converter operating with reduced AC power in the



DClink capacitor,” IEEE Trans. Power Electron., vol. 25, no. 2, pp. 272–279, Feb. 2010.

3. D. Lamar, J. Sebastian, M. Arias, and A. Fernandez, “On the limit of the output

capacitor reduction in power-factor correctors by distorting the line input current,” IEEE Trans. Power Electron., vol. 27, no. 3, pp. 1168–1176, Mar.

2012.