

## ANN based D-FACTS for Power Quality Enhancement in Microgrid

<sup>1</sup> Mr. B. Rajesh Kumar, <sup>2</sup> Mr. C. Magesh Kumar

<sup>1,2</sup> Assistant Professor, Dept. of CSE,

Malla Reddy Engineering College (Autonomous), Secunderabad, Telangana State

### Abstract:

This paper proposes the concept of D-STATCOM and adaptive switched filter compensator to mitigate the power quality problems in distributed system. The key parameters for power quality measurements are voltage distortions such as sag & swell, current harmonics caused by different load conditions. A conventional PID controller is used for regulating the dc link voltages of D-FACTS and ASFC controllers to compensate the power quality problems. The parameter tuning of PID controller is the major criteria. A grasshopper optimization is implemented for tuning of PID controller. The GOA based PID controller compensate the 80% of harmonic distortions and voltage distortions. To improve the harmonic distortions and compensate voltage distortions, the dc link voltage can be regulated with ANN controller.

### INTRODUCTION

In the advancement of power semiconductor devices, such as thyristors, Gate Turn off thyristors, Insulated Gate Bipolar Transistors and many more devices, which are used to control electric power.

In three phase systems, the power electronics devices could also cause unbalances in voltage and draw excessive neutral currents due to their disturbances. Due to because of these injected harmonics, reactive power burden, unbalance, and excessive neutral currents causes efficiency reduction and poor power factor. Therefore, improvement of power quality is one of the important issue since many loads at various distribution ends. Basically, the term Power Quality mainly deals with problems occurred in the system like improvement of voltage levels at the Point of Common Coupling (PCC) for various distribution voltage levels irrespective of voltage fluctuations, maintaining near unity power factor power drawn from the supply, blocking of voltage and current unbalance from passing upwards from various distribution levels, reduction of voltage and current harmonics in the system and suppression of excessive supply neutral current. Conventionally, passive LC filters has been used but these devices have the demerits of fixed compensation, large size, ageing and resonance. Nowadays these constraints cannot be overcome otherwise, while maintaining the required system stability, by mechanical means without lowering the useable transmission capacity. By providing added flexibility, FACTS controller can enable a line to carry power closer to its thermal rating. Mechanical switching needs to be supplemented by rapid-response power electronics [13]. The facts technology can certainly be used to overcome any to the stability limits, in which case the ultimate limits would be thermal and dielectric.

## PROPOSED SYSTEM:

The proposed MG includes solar PV, WES, BESS and PEMFC. Each of these resources is connected to its LC, which in turn is connected to the MGCC. The MGCC can be connected to the host (or utility) grid through the distribution system operator (DSO) if it is desired or needed. The LC encompasses a breaker for switching operation of its connected resource and maximum power point tracking (MPPT) circuit. DER-bus is connected to the load-bus at 380V, 50 Hz. Fig. 1 shows the isolated MG with a control system structure including the power quality enhancement device (PQED) at the PCC.

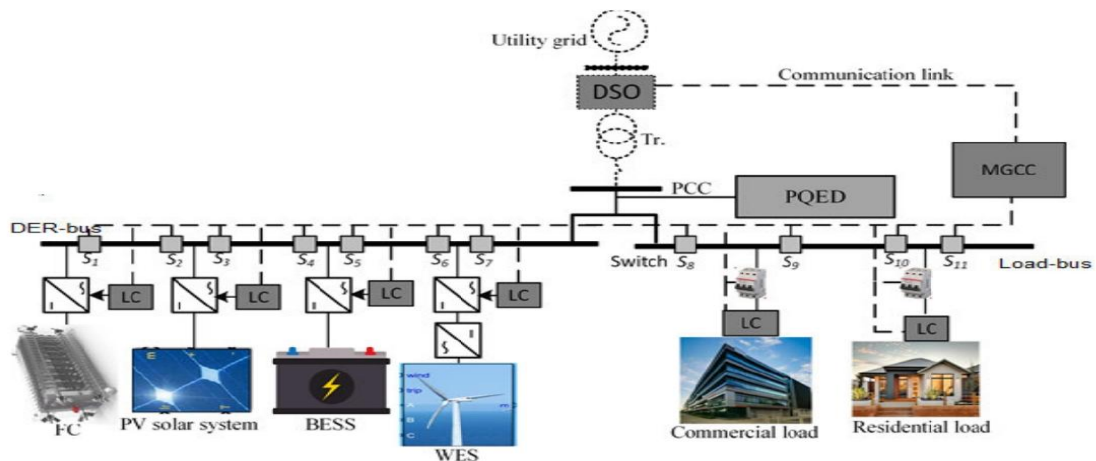

Figure 1: Diagram of an isolated MG with control system structure

## PV and Wind Modeling

### Photovoltaic Array

In the PV network of electrical phenomenon, cell is the necessary part. For the raise in appropriate current, high power and potential difference, the sunlight dependent cells and their region unit joined in non-current or parallel fashion called as PV exhibit are used. In practical applications, each and every cell is similar to diode with the intersection designed by the semiconductor material [5]. When the light weight is absorbed by the electrical marvel sway at the point of intersection, it gives the streams at once. The (current-voltage) and (Power-Voltage) attributes at absolutely unpredictable star intensities of the PV exhibit are represented in Figure 3, whereas the often-seen existence of most electrical outlet on each yield is shown in PV cell diagram is shown in Figure 2 [14].

$$I = I_{ph} - I_D - I_{sh}$$

$$I = I_{ph} - I_o \left[ e^{\left( \frac{qV_D}{nKT} \right)} \right] - \left( \frac{V_D}{R_s} \right)$$

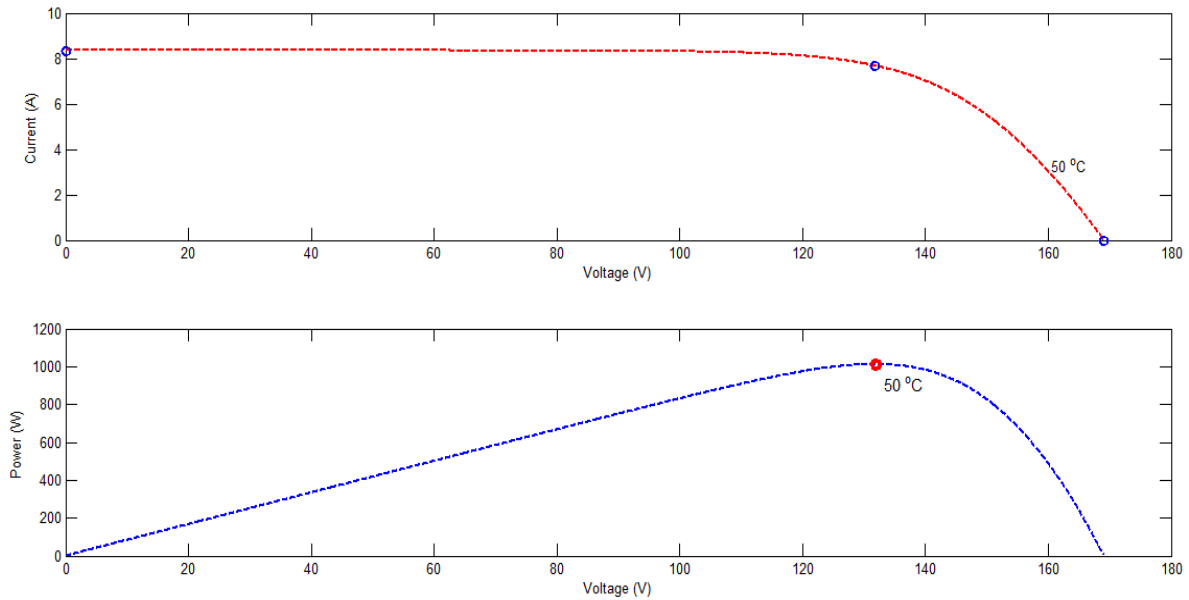

Fig. 2. Response of output characteristics of PV Array

### Wind Energy System

The wind energy system converts wind energy to mechanical energy with turbine and further it converted to electrical energy with help of generator. It consists of gear box mechanism for converting low speed shaft to high speed shaft and it applied to generator. The classification of generators is mainly two type's i.e synchronous generator and induction generator [7], and pitch angle controller also used to get the maximum efficiency irrespective of wind direction. Pitch angle moves the blades position w.r.t wind direction. Basically, wind systems are classified into two types (a) Horizontal Axis and (b) Vertical axis wind turbines.

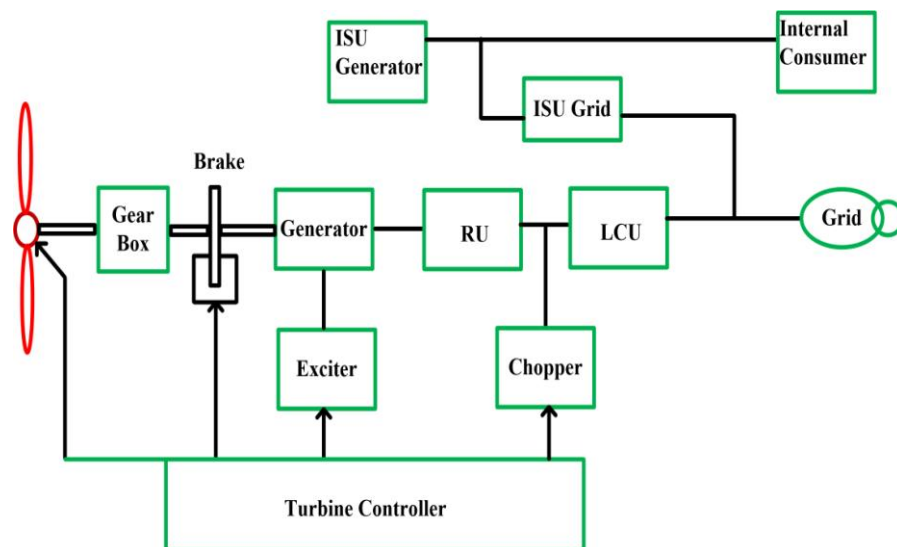

Fig. 3. Basic diagram of wind turbine

The structure of wind turbine shown in figure 4, consists of following components, the gear box is used to convert the low speed shaft to high speed shaft and applied to generator, the output of the generator is converted to dc using rectifying unit(RU)and connected to Line Control Unit (LCU), which is used to regulate the wind output to meet grid requirement [8]. An extra units is used to give the power to internal auxiliaries of wind turbine (like motor, battery etc.), this is called Internal Supply Unit (ISU).

The mathematical modelling of Wind Energy System is expressed as

$$P_{mech} = \frac{1}{2} C_p (\lambda, \beta) A \rho v^3$$

### Proton exchange fuel cells:

In the archetypal hydrogen–oxygen proton exchange membrane fuel cell (PEMFC) design, a proton-conducting polymer membrane, (the electrolyte), separates the anode and cathode sides. This was called a "solid polymer electrolyte fuel cell" (SPEFC) in the early 1970s, before the proton exchange mechanism was well-understood. (Notice that "polymer electrolyte membrane" and "proton exchange mechanism" result in the same acronym).

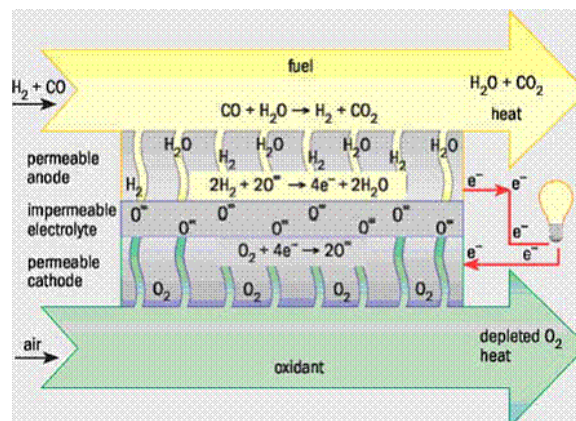

Fig 4: Operating principle of Fuel Cell

### D-STATCOM Controller:

The switching converter forms the heart of the FACTS controllers. Controllable reactive power can be generated by the DC to AC switching converters which are switched in synchronism with the line voltage with which the reactive power is exchanged. A switching power converter consists of an array of solid state switches which connect the input terminals to the output terminals. It has no internal storage and so the instantaneous input and output power are equal. Further the input and output terminations are complementary, that is, if the input is terminated by a voltage source (charged capacitor or battery), output is a current source (which means a voltage source having an inductive impedance) and vice versa. Thus, the converter can be voltage sourced (shunted by a capacitor or battery) or current sourced (shunted by an inductor).



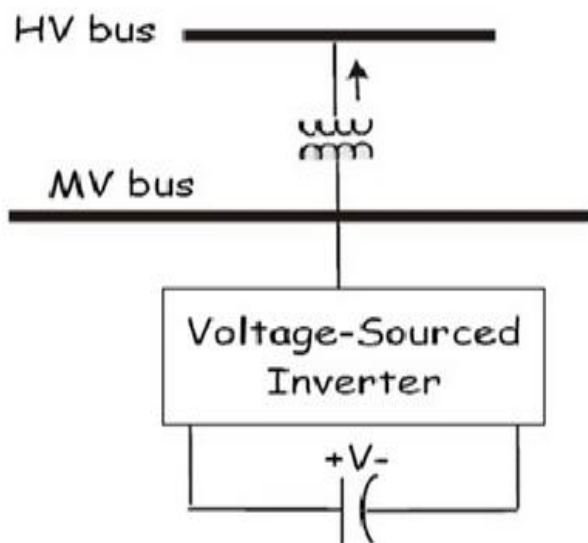

Figure 5: Operation of Converter

Single line diagram of basic voltage sourced converter scheme for reactive power generation is shown in figure 6 for reactive power flow bus voltage  $V$  and converter terminal voltage  $V_0$  are in phase. Then on per phase basis

$$I = \frac{V - V_0}{X}$$

The reactive power exchange is

$$Q = VI = \frac{V(V - V_0)}{X}$$

The switching circuit is capable of adjusting  $V_0$  the output voltage of the converter.

### ADAPTIVE SWITCHED FILTER COMPENSATOR (ASFC)

To improve the performance of the isolated MG, the proposed ASFC is applied to the load bus at PCC. The ASFC is a switched/modulated filter that consists of a fixed shunt condenser bank linked to the AC side of an uncontrolled rectifier's arm. The proposed ASFC is a low-cost device compared to other shunt-connected FACTS devices, e.g., the D-STATCOM as reported in Reference. It only uses one solid-state low-power switch with a 2-pulse low rating diode rectifier. This is approximately one-fourth of the D-STATCOM cost. The ASFC construction and the PID controller circuit are shown in Figure 6.

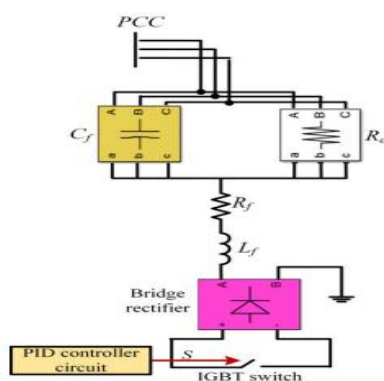

Figure 6: The proposed ASFC

### Artificial Neural Networks:

The structure of an ANN, in which a circle indicates a fixed node, whereas a square indicates an adaptive node, is shown in Figure 7. In this structure, there are input and output nodes, and in the hidden layers, there are nodes functioning as membership functions (MFs) and rules. This eliminates the disadvantage of a normal feed forward multilayer network, which is difficult for an observer to understand or to modify. For simplicity, we assume that the examined FIS has two inputs and one output. In this network, each element of the input vector  $p$  is connected to each neuron input through the weight matrix  $W$ . The  $i$ th neuron has a summer that gathers its weighted inputs and bias to form its own scalar output  $n(i)$ . The various  $n(i)$  taken together form an  $S$ -element net input vector  $n$ .

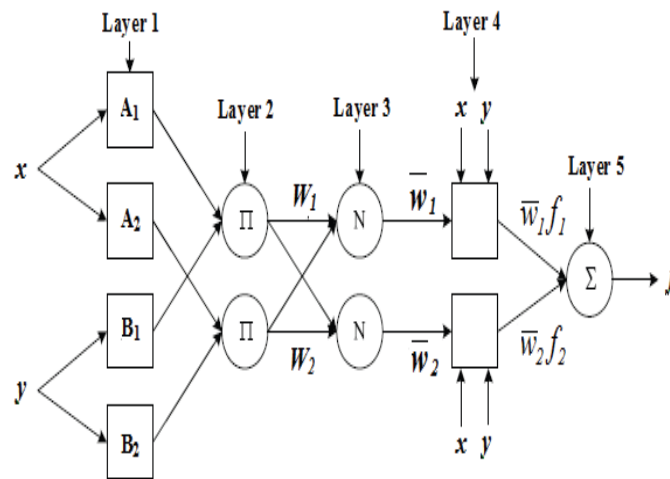

Fig 7 ANN architecture for a two-input multi-layer network

Where  $x$  and  $y$  are the two crisp inputs, and  $A_i$  and  $B_i$  are the linguistic labels associated with the node function. As indicated in Fig, the system has a total of five layers.

### SIMULATION DIAGRAMS & RESULTS:

Based on the mathematical models of each component of the MG, the overall structure of the MG simulation model including a PQED is shown in Fig. 1. It is to be noted that the simulation model leads to results that may differ from the practical solutions because of the delays occurred in real system. To improve the performance of the isolated MG, the proposed ASFC is applied to the load bus at PCC. The ASFC is a switched/modulated filter that consists of a fixed shunt condenser bank linked to the AC side of an uncontrolled rectifier's arm. The proposed ASFC is a low-cost device compared to other shunt-connected FACTS devices, e.g., the D-STATCOM.

#### Case 1: Proposed System is implemented with Dynamic Load

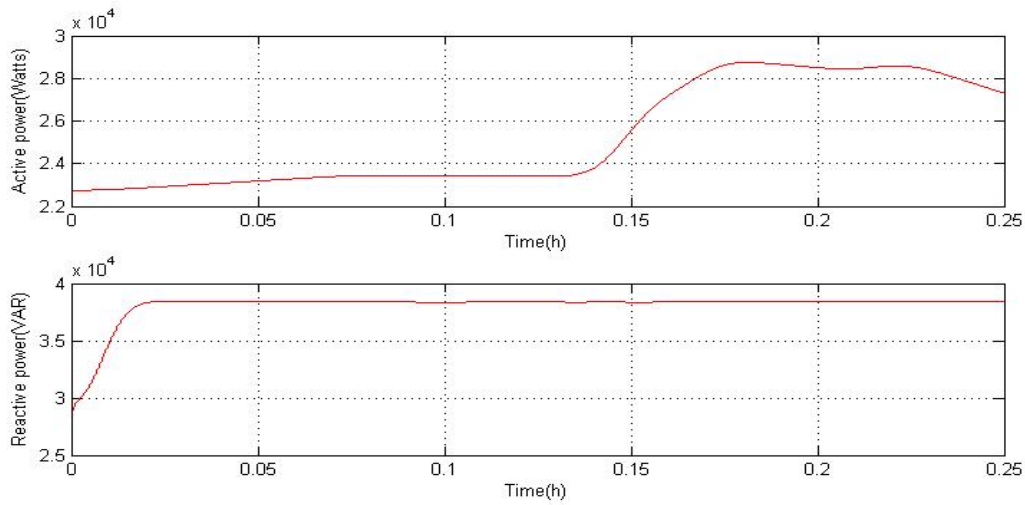

Figure 8: Simulation Result for Active and Reactive Powers at Load1 with ANN Controller

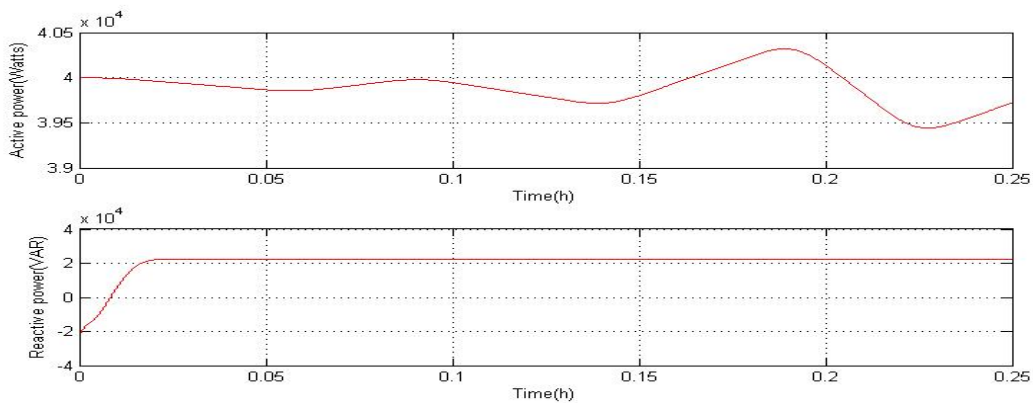

Figure 9: Simulation Result for Active and Reactive Powers at Load2 with ANN Controller

## CONCLUSION:

An ASFC compensation scheme using a ANN controller for finding the optimum values of PI gains and minimizing the harmonics has been proposed. Different case studies are performed to validate the effectiveness of the proposed ASFC. The simulation results illustrate an improvement of power quality aspects such as dynamic voltage stabilization, mitigation of harmonics distortion, reduction of the consumed reactive power and power factor. The simulation results have been clarified an improvement in the THD<sub>v</sub> using the ANN, compared with modified D-STATCOM and the ASFC. For reactive power compensation, the enhancement rate using the ASFC is approximately 6.8%, while for the modified D-STATCOM and conventional SFC are 2.3 % and 4.2 %, respectively. The proposed ANN based ASFC can operate on real times as its parameters can be self-tuned to accommodate the present operating conditions. Furthermore, the D-STATCOM as an alternative device for improving the PQ of the MG is modified to be self-tuned and more effective.

## REFERENCES

- [1] H. Zou, S. Mao, Y. Wang, F. Zhang, X. Chen, and L. Cheng, "A survey of energy management in interconnected multi-microgrids," *IEEE Access*, vol. 7, pp. 72158–72169, 2019, doi: 10.1109/ACCESS.2019.2920008.
- [2] Q. Liu, Y. Li, L. Luo, Y. Peng, and Y. Cao, "Power quality management of PV power plant with transformer integrated filtering method," *IEEE Trans. Power Del.*, vol. 34, no. 3, pp. 941–949, Jun. 2019, doi: 10.1109/TPWRD.2018.2881991.
- [3] Y. Rajendra Babu, Dr.C.Srinivasa Rao, "Power Quality Improvement Using Intelligent Control Based Distributed Generation inverter", *International Journal of Management, Technology And Engineering*, 2019.
- [4] Krishna Mohan Tatikonda, Udaya K. Renduchintala, Chengzong Pang, and Lin Yang, "ANFIS- fuzzy logic based UPQC in interconnected microgrid distribution systems: Modeling, simulation and implementation," 2021 The Authors. *The Journal of Engineering* published by John Wiley & Sons Ltd on behalf of The Institution of Engineering and Technology, <https://doi.org/10.1049/tje2.12005>.
- [5] N.Saida Naik L.Srujana, A.Sai Pallavi, "Harmonic source current reduction using shunt active filters with fuel cell", *Journal of Applied Science and Computations*, 2019.
- [6] Y. Rajendra Babu, B. Sai Kumar, P. Dinesh Kumar, A.Sai Chandu, V. Naveen Kumar, "A novel fuzzy controlled grid-tied pv fed h-bridge multilevel inverter for compensation of unbalanced situation", *Jour of adv research in dynamical & control systems*, 2017.
- [7] T. Eswara Rao, Krishna Mohan Tatikonda, S. Elango, and J. Charan Kumar, "MICROGRID TECHNOLOGIES", Edited by C. Sharmeela, P. Sivaraman, P. Sanjeevikumar, and Jens Bo Holm-Nielsen, Scrivener Publishing, ISBN: 9781119710790.
- [8] H. A. Gabbar and A. A. Abdelsalam, "Microgrid energy management in grid-connected and islanding modes based on SVC," *Energy Convers. Manage.*, vol. 86, pp. 964–972, Oct. 2014, doi: 10.1016/j.enconman.2014.06.070.
- [9] A. A. Abdelsalam and A. M. Sharaf, "A novel facts compensation scheme for power quality improvement in wind Smart Grid," in *Proc. 25th IEEE Can. Conf. Electr. Comput. Eng. (CCECE)*, Apr. 2012, pp. 1–4.
- [10] Y. Rajendra Babu, C. Srinivasa Rao, "A critical evaluation of power quality features using dual apf under grid interfaced dg scheme", *Indonesian journal of electrical engineering and computer science*, 2017.
- [11] Praveen. V, Dr. Snv Ganesh, "Reduction of voltage disturbances in distribution system using neural controller", *International journal of innovative and emerging research in engineering*, 2017.





[12] A Sekhar Sunil, Moganti Sanjay, Nutakki Mounica "SIMULATION OF A POWER ELECTRONIC TRANSFORMER FOR IMPROVING POWER QUALITY", 2017-International Journal of Modern Trends in Engineering and Science

[13] A.Sekhar Sunil,Y.Anne Janet,N.Mounica"A Cascaded H-Bridge Multilevel Inverter Using Switched Parallel DC Voltage Sources"2017 International Journal for Modern Trends in Science and Technology.

[14] A.Sekhar Sunil,S.Priyanka and K.Tejaswi "A Control Method for UPQC Based on SRF Theory Under Unbalanced and Distorted Load Conditions "2017 International Journal for Modern Trends in Science and Technology