



International Journal for Innovative Engineering and Management Research

A Peer Reviewed Open Access International Journal

www.ijiemr.org

COPY RIGHT

2017 IJIEMR. Personal use of this material is permitted. Permission from IJIEMR must be obtained for all other uses, in any current or future media, including reprinting/republishing this material for advertising or promotional purposes, creating new collective works, for resale or redistribution to servers or lists, or reuse of any copyrighted component of this work in other works. No Reprint should be done to this paper, all copy right is authenticated to Paper Authors

IJIEMR Transactions, online available on 30th Aug 2017. Link

[:http://www.ijiemr.org/downloads.php?vol=Volume-6&issue=ISSUE-7](http://www.ijiemr.org/downloads.php?vol=Volume-6&issue=ISSUE-7)

Title: DESIGN AND SIMULATION OF FUZZY LOGIC BASED IUPQC CONTROLLER TO IMPROVE POWER QUALITY FED NON-LINEAR LOADS

Volume 06, Issue 07, Pages: 480 – 491.

Paper Authors

BANOTH GOPI,V.NARESH KUMAR

KLR Engineering College, Paloncha;Bhadradri Kothagudem (Dt); Telangana, India.



USE THIS BARCODE TO ACCESS YOUR ONLINE PAPER

To Secure Your Paper As Per **UGC Guidelines** We Are Providing A Electronic Bar Code

DESIGN AND SIMULATION OF FUZZY LOGIC BASED IUPQC CONTROLLER TO IMPROVE POWER QUALITY FED NON-LINEAR LOADS

¹BANOTH GOPI, ²V.NARESH KUMAR

¹M-tech Student Scholar Department of Electrical & Electronics Engineering, KLR Engineering College, Paloncha; Bhadradri Kothagudem (Dt); Telangana, India.

²Assistant Professor Department of Electrical & Electronics Engineering, KLR Engineering College, Paloncha; Bhadradri Kothagudem (Dt); Telangana, India.

ABSTRACT—In this paper Fuzzy based Interline Unified Power Quality Conditioner (iUPQC) for power quality Enhancement is presented. The iUPQC is a Unified Power Quality Conditioner in which the series converter emulates a sinusoidal current source and the shunt converter emulates a sinusoidal voltage source. The main causes of a poor power quality are harmonic currents, poor power factor, supply voltage variations, etc. A Fuzzy Logic Controller (FLC) is based on fuzzy sets and fuzzy rules with their membership functions of inputs and outputs. A control technique of two active filters is to control the sinusoidal reference. In iUPQC; Series Active Filter (SAF) works as a current source and Parallel Active Filter (PAF) works as a voltage source and due to these there is a high and low impedances occurs which is indirectly compensates the harmonics and disturbances of the grid voltage and load current and also impedance path is low harmonic at load current. By using this controller, beyond the conventional UPQC power quality features, including voltage sag/swell compensation, the iUPQC will also provide reactive power support to regulate not only the load-bus voltage but also the voltage at the grid-side bus. In other words, the iUPQC will work as a static synchronous compensator (STATCOM) at the grid side, while providing also the conventional UPQC compensations at the load or micro grid side. A simulation design control, power flow analysis is proposed in interline unified power quality controller (iUPQC) and to eliminate harmonics using a Fuzzy Logic Controller (FLC) performance can be evaluated by using MATLAB/SIMULINK software.

Index Terms—iUPQC, microgrids, power quality, Fuzzy Logic controller, unified power quality conditioner (UPQC).

I. INTRODUCTION

However, the increasing number of power-electronics-driven loads used generally in the industry has brought about uncommon power quality problems. In contrast, power-electronics driven loads generally require ideal sinusoidal supply voltage in order to function properly, whereas they are the most responsible ones for

abnormal harmonic currents level in the distribution system. In this scenario, devices that can mitigate these drawbacks have been developed over the years. Performance of the compensator. Certainly, power-electronics devices have brought about great technological improvements. The Usage of power quality

conditioners in the distribution system network has increased during the past years due to the steady increase of nonlinear loads connected to the Electrical grid. The current drained by nonlinear loads has a high harmonic content, distorting the voltage at the utility grid and consequently affecting the operation of critical loads [1-3]. By using a unified power quality conditioner (UPQC) it is possible to ensure a regulated voltage for the loads, balanced and with low harmonic distortion and at the same time draining undistorted currents from the utility grid, even if the grid voltage and the load current have harmonic contents. The UPQC consists of two active filters, the series active filter (SAF) and the shunt or parallel active filter (PAF). The PAF is usually controlled as a non-sinusoidal current source, which is responsible for compensating the harmonic current of the load, while the SAF is controlled as a non-sinusoidal voltage source, which is responsible for compensating the grid voltage. Both of them have a control reference with harmonic contents, and usually, these references might be obtained through complex methods [4-6]. The line conditioner consists of two single phase current source inverters where the SAF is controlled by a current loop and the PAF is controlled by a voltage loop. In this way, both grid current and load voltage are sinusoidal, and therefore, their references are also sinusoidal. The aim of this is to propose dual three-phase four wire unified power quality conditioner (iUPQC) by using fuzzy logic in shunt active filter. It is to be used in the utility grid connection. Fuzzy logic control methodology has been demonstrated to allow solving uncertain and vague problems.

In this paper fuzzy logic controller is used for generation of switching pulses for PWM controllers [7]. The advantages of using fuzzy system are simplicity, ease of application, flexibility, speed and ability to deal with imprecision and uncertainties. Due to absorbing and supplying of active and reactive power in active filter, the capacitance voltage is not maintained constant. In literature many controllers are used for capacitance balancing, such as PI, PID, and fuzzy logic controller. In this paper, fuzzy control algorithm is used to balance the dc voltage of capacitance in order to improve the performance of controller. The proposed method is evaluated and tested under non-sinusoidal source voltage conditions using Matlab/Simulink software. The performance of UPQC depends on the characteristic of the active filters. The fuzzy logic controller is used in almost all sectors of industry and power systems and science and one among them is harmonic current and reactive power compensation [8]. In this way, both grid current and load voltage are sinusoidal, and therefore, their references are also sinusoidal. Some authors have applied this concept, using voltage source inverters in uninterruptable power supplies and in UPQC [9]. In [10], this concept is called “dual topology of unified power quality conditioner” (iUPQC), and the control schemes use the p-q theory, requiring determination in real time of the positive sequence components of the voltages and the currents. The aim of this project is to propose a simplified control technique for a dual three-phase topology of a unified power quality conditioner (iUPQC) to be used in the utility grid connection. The proposed control scheme is developed in ABC reference frame and allows the use of classical control

theory without the need for coordinate transformers and digital control implementation. The references to both SAF and PAFs are sinusoidal, dispensing the harmonic extraction of the grid current and load voltage [11-14]. The performance of the IUPQC has been evaluated through simulation studies using MATLAB.

II. EQUIPMENT APPLICABILITY

In order to clarify the applicability of the improved iUPQC controller depicts an electrical system with two buses in spotlight, i.e., bus A and bus B. Bus A is a critical bus of the power system that supplies sensitive loads and serves as point of coupling of a microgrid. Bus B is a bus of the microgrid, where nonlinear loads are connected, which requires premium-quality power supply. The voltages at buses A and B must be regulated, in order to properly supply the sensitive loads and the nonlinear loads. The effects caused by the harmonic currents drawn by the nonlinear loads should be mitigated, avoiding harmonic voltage propagation to bus A. The use of a STATCOM to guarantee the voltage regulation at bus A is not enough because the harmonic currents drawn by the nonlinear loads are not mitigated. On the other hand, a UPQC or an iUPQC between bus A and bus B can compensate the harmonic currents of the nonlinear loads and compensate the voltage at bus B, in terms of voltage harmonics, unbalance, and sag/swell. Nevertheless, this is still not enough to guarantee the voltage regulation at bus A. Hence, to achieve all the desired goals, a STATCOM at bus A and a UPQC (or an iUPQC) between buses A and B should be employed. However, the costs of this solution would be unreasonably high. An attractive solution would be the use of a modified iUPQC controller to provide also

reactive power support to bus A, in addition to all those functionalities of this equipment, as presented. Note that the modified iUPQC serves as an intertie between buses A and B. Moreover, the microgrid connected to the bus B could be a complex system comprising distributed generation, energy management system, and other control systems involving microgrid, as well as smart grid concepts.

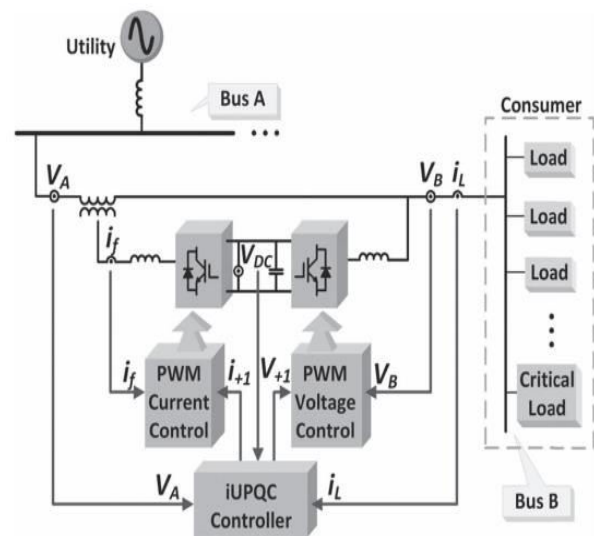

Fig.1. Modified iUPQC Configuration

In summary, the modified iUPQC can provide the following functionalities:

- “Smart” circuit breaker as an intertie between the grid and the microgrid;
- Energy and power flow control between the grid and the microgrid (imposed by a tertiary control layer for the microgrid);
- Reactive power support at bus A of the power system;
- voltage/frequency support at bus B of the microgrid;
- Harmonic voltage and current isolation between bus A and bus B (simultaneous grid-voltage and load-current active filtering capability);
- Voltage and current imbalance compensation.

According to the conventional iUPQC controller, the shunt converter imposes a controlled sinusoidal voltage at bus B, which corresponds to the aforementioned functionality (d). As a result, the shunt converter has no further degree of free domain terms of compensating active- or reactive-power variables to expand its functionality. On the other hand, the series converter of a conventional iUPQC uses only an active-power control variable p , in order to synthesize a fundamental sinusoidal current drawn from bus A, corresponding to the active power demanded by bus B. If the dc link of the iUPQC has no large energy storage system or even no energy source, the control variable p also serves as an additional active-power reference to the series converter to keep the energy inside the dc link of the iUPQC balanced. In this case, the losses in the iUPQC and the active power supplied by the shunt converter must be quickly compensated in the form of an additional active power injected by the series converter into the bus B.

The iUPQC can serve as:

- “Smart” circuit breaker and as
- Power flow controller between the grid and the microgrid only if the compensating active- and reactive-power references of the series converter can be set arbitrarily. In this case, it is necessary to provide an energy source (or large energy storage) associated to the dc link of the iUPQC. The last degree of freedom is represented by a reactive-power control variable \bar{q} for the series converter of the iUPQC. In this way, the iUPQC will provide reactive-power compensation like a STATCOM to the bus A of the grid. As it will be confirmed, this functionality can be added into the controller without degrading all other functionalities of the iUPQC.

III. IMPROVED IUPQC CONTROLLER

A. Main Controller

Fig.1. depicts the iUPQC hardware and the measured units of a three-phase three-wire system that are used in the controller. Fig.2. shows the proposed controller. The controller inputs are the voltages at buses A and B, the current demanded by bus B (i_L), and the voltage v_{DC} of the common dc link. The outputs are the shunt-voltage reference and the series-current reference to the pulse width modulation (PWM) controllers. The voltage and current PWM controllers can be as simple as those employed, or be improved further to better deal with voltage and current imbalance and harmonics. First, the simplified Clark transformation is applied to the measured variables. As example of this transformation, the grid voltage in the $\alpha\beta$ -reference frame can be calculated as

$$\begin{bmatrix} V_{A_ \alpha} \\ V_{A_ \beta} \end{bmatrix} = \begin{bmatrix} 1 & 1/2 \\ 0 & \sqrt{3}/2 \end{bmatrix} \begin{bmatrix} V_{A_ ab} \\ V_{A_ bc} \end{bmatrix} \quad (1)$$

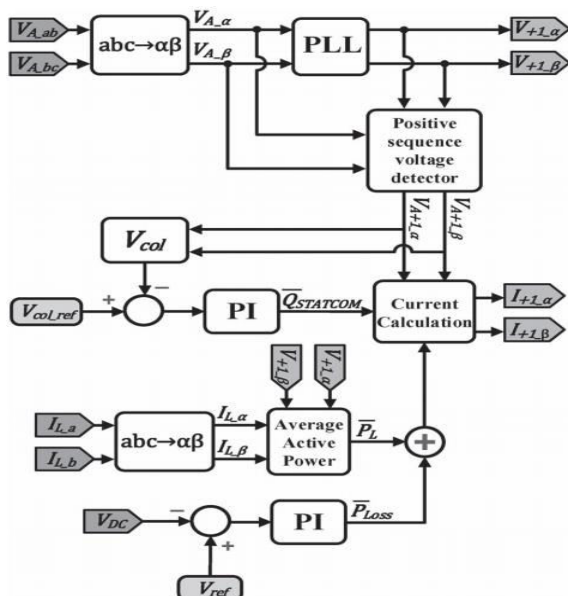

Fig.2. Novel iUPQC controller

The shunt converter imposes the voltage at bus B. Thus, it is necessary to synthesize sinusoidal voltages with nominal amplitude and frequency. Consequently, the signals sent to the PWM controller are the phase-locked loop (PLL) outputs with amplitude equal to 1 p.u. In the original iUPQC approach as presented, the shunt-converter voltage reference can be either the PLL outputs or the fundamental positive-sequence component V_{A+1} of the grid voltage (bus A in Fig.1.). The use of V_{A+1} in the controller is useful to minimize the circulating power through the series and shunt converters, under normal operation, while the amplitude of the grid voltage is within an acceptable range of magnitude. However, this is not the case here, in the modified iUPQC controller, since now the grid voltage will be also regulated by the modified iUPQC. In other words, both buses will be regulated independently to track their reference values. The series converter synthesizes the current drawn from the grid bus (bus A). In the original approach of iUPQC, this current is calculated through the average active power required by the loads \bar{P}_L plus the power \bar{P}_{Loss} . The load active power can be estimated by

$$P_L = V_{+1_α} \cdot i_{L_α} + V_{+1_β} \cdot i_{L_β} \quad (2)$$

Where $i_{L_α}$, $i_{L_β}$ are the load currents, and $V_{+1_α}$, $V_{+1_β}$ are the voltage references for the shunt converter. A low-pass filter is used to obtain the average active power (\bar{P}_L). The losses in the power converters and the circulating power to provide energy balance inside the iUPQC are calculated indirectly from the measurement of the dc-link voltage. In other words, the power signal \bar{P}_{Loss} is determined by a proportional-integral (PI) controller (PI block in Fig. 2), by

comparing the measured dc voltage VDC with its reference value. The additional control loop to provide voltage regulation like a STATCOM at the grid bus is represented by the control signal $\bar{Q}_{STATCOM}$ in Fig.2. This control signal is obtained through a PI controller, in which the input variable is the error between the reference value and the actual aggregate voltage of the grid bus, given by

$$V_{col} = \sqrt{V_{A+1_α}^2 + V_{A+1_β}^2} \quad (3)$$

The sum of the power signals \bar{P}_L and \bar{P}_{Loss} composes the active-power control variable for the series converter of the iUPQC (\bar{p}) described in Section II. Likewise, $\bar{Q}_{STATCOM}$ is the reactive-power control variable q . Thus, the current references $i_{+1α}$ and $i_{+1β}$ of the series converter are determined by

$$\begin{bmatrix} i_{+1_α} \\ i_{+1_β} \end{bmatrix} = \frac{1}{V_{A+1_α}^2 + V_{A+1_β}^2} \begin{bmatrix} V_{A+1_α} & V_{A+1_β} \\ V_{A+1_β} & -V_{A+1_α} \end{bmatrix} \times \begin{bmatrix} \bar{P}_L + \bar{P}_{Loss} \\ \bar{Q}_{STATCOM} \end{bmatrix} \quad (4)$$

B. Power Flow in Steady State

The following procedure, based on the average power flow, is useful for estimating the power ratings of the iUPQC converters. For combined series-shunt power conditioners, such as the UPQC and the iUPQC, only the voltage sag/swell disturbance and the power factor (PF) compensation of the load produce a circulating average power through the power conditioners. According to Fig.3, the compensation of a voltage sag/swell disturbance at bus B causes a positive sequence voltage at the coupling transformer ($V_{series} \neq 0$), since $V_A \neq V_B$. Moreover, V_{series} and i_{PB} in the coupling transformer leads to a circulating active power \bar{P}_{inner} in the iUPQC.

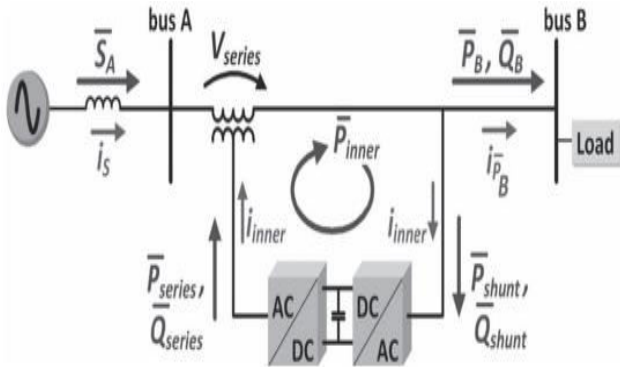

Fig. 3. iUPQC power flow in steady-state

Additionally, the compensation of the load PF increases the current supplied by the shunt converter. The following analysis is valid for an iUPQC acting like a conventional UPQC or including the extra compensation like a STATCOM. First, the circulating power will be calculated when the iUPQC is operating just like a conventional UPQC. Afterward, the equations will include the STATCOM functionality to the grid bus A. In both cases, it will be assumed that the iUPQC controller is able to force the shunt converter of the iUPQC to generate fundamental voltage always in phase with the grid voltage at bus A. For simplicity, the losses in the iUPQC will be neglected. For the first case, the following average powers in steady state can be determined:

$$\bar{S}_A = \bar{P}_B \quad (5)$$

$$\bar{Q}_{shunt} = -\bar{Q}_B \quad (6)$$

$$\bar{Q}_{series} = \bar{Q}_A = 0 \text{ var} \quad (7)$$

$$\bar{P}_{series} = \bar{P}_{shunt} \quad (8)$$

Where \bar{S}_A and \bar{Q}_A are the apparent and reactive power injected in the bus A; \bar{P}_B and \bar{Q}_B are the active and reactive power injected in the bus B; \bar{P}_{shunt} and \bar{Q}_{shunt} are the active and reactive power drained by the shunt converter; \bar{P}_{series} and \bar{Q}_{series} are the active and reactive power supplied by the series converter, respectively. Equations (5) and (8) are derived from the constraint of keeping unitary the PF at bus A. In this case, the current passing through the series converter is responsible only for supplying the load active power, that is, it is in phase (or counter phase) with the voltages V_A and V_B . Thus, (7) can be stated. If a voltage sag or swell occurs, \bar{P}_{series} and \bar{P}_{shunt} will not be zero, and thus, an inner-loop current (i_{inner}) will appear. The series and shunt converters and the aforementioned circulating active power (\bar{P}_{inner}) flow inside the equipment. It is convenient to define the following sag/swell factor. Considering V_N as the nominal voltage

$$k_{sag/swell} = \frac{|\dot{V}_A|}{|\dot{V}_N|} = \frac{V_A}{V_N} \quad (9)$$

From (5) and considering that the voltage at bus B is kept regulated, i.e., $V_B = V_N$, it follows that

$$\begin{aligned} \sqrt{3} \cdot k_{sag/swell} \cdot V_N \cdot i_S &= \sqrt{3} \cdot V_N \cdot i_{P_B} \\ i_S &= \frac{i_{P_B}}{k_{sag/swell}} = i_{P_B} + i_{inner} \end{aligned} \quad (10)$$

$$i_{inner} = \left| i_{P_B} \left(\frac{1}{K_{sag/swell} - 1} \right) \right| \quad (11)$$

The circulating power is given by

$$\bar{P}_{inner} = \bar{P}_{series} = \bar{P}_{shunt} = 3(V_B - V_A)(i_{P_B} + i_{inner}) \quad (12)$$

From (11) and (12), it follows that

$$\bar{P}_{inner} = 3(V_N - V_A) \left(\frac{\bar{P}_B}{3V_N k_{sag/swell}} \right) \quad (13)$$

$$\bar{P}_{inner} = \bar{P}_{series} = \bar{P}_{shunt} = \frac{1 - K_{sag/swell}}{k_{sag/swell}} \bar{P}_B \quad (14)$$

Thus, (14) demonstrates that \bar{P}_{inner} depends on the active power of the load and the sag/swell voltage disturbance. In order to verify the effect on the power rate of the series and shunt converters, a full load system $\bar{S}_B = \sqrt{\bar{P}_B^2 + \bar{Q}_B^2} = 1 \text{ p.u.}$ with PF ranging from 0 to 1 was considered. It was also considered the sag/swell voltage disturbance at bus A ranging $k_{sag/swell}$ from 0.5 to 1.5. In this way, the power rating of the series and shunt converters are obtained through (6)–(8) and (14). The apparent power of the series and shunt power converters. In these figures, the $k_{sag/swell}$ -axis and the PF-axis are used to evaluate the power flow in the series and shunt power converters according to the sag/swell voltage disturbance and the load power consumption, respectively. The power flow in the series converter indicates that a high power is required in case of sag voltage disturbance with high active power load consumption. In this situation, an increased \bar{P}_{inner} arises and high rated power converters are necessary to ensure the disturbance compensation. Moreover, in case of compensating sag/swell voltage disturbance

with high reactive power load consumption, only the shunt converter has high power demand, since \bar{P}_{inner} decreases. It is important to highlight that, for each PF value, the amplitude of the apparent power is the same for capacitive or inductive loads. In other words, the same for \bar{Q}_B capacitive or inductive. If the iUPQC performs all original UPQC functionalities together with the STATCOM functionality, the voltage at bus A is also regulated with the same phase and magnitude, that is, $\dot{V}_A = \dot{V}_B = \dot{V}_N$, and then, the positive sequence of the voltage at the coupling transformer is zero ($\bar{V}_{series} = 0$). Thus, in steady state, the power flow is determined by

$$\bar{S}_A = \bar{P}_B + \bar{Q}_{STATCOM} \quad (15)$$

$$\bar{Q}_{STATCOM} + \bar{Q}_{series} = \bar{Q}_{shunt} + \bar{Q}_B \quad (16)$$

$$\bar{Q}_{series} = 0 \text{ var} \quad (17)$$

$$\bar{P}_{series} = \bar{P}_{inner} = 0 \text{ W} \quad (18)$$

Where $\bar{Q}_{STATCOM}$ is the reactive power that provides voltage regulation at bus A. Ideally, the STATCOM functionality mitigates the inner-loop active power flow (\bar{P}_{inner}), and the power flow in the series converter is zero. Consequently, if the series converter is properly designed along with the coupling transformer to synthesize the controlled currents I_{+1_a} and I_{+1_b} , as shown in Fig.3, then a lower power converter can be employed. Contrarily, the shunt converter still has to provide the full reactive power of the load and also to drain the reactive

power injected by the series converter to regulate the voltage at bus A.

IV. FUZZY LOGIC CONTROL

➤ Fuzzification

The first step in the design of a fuzzy logic controller is to define membership functions for the inputs. Seven fuzzy levels or sets are chosen and defined by the following library of fuzzy-set values for the error and change in error. They are as follows

- NB negative big
- NM negative medium
- NS negative small
- ZE zero equal
- PS positive small
- PM positive medium
- PB positive big
- ❖ The number of fuzzy levels is not fixed and depends on the input resolution needed in an application.
- ❖ The larger the number of fuzzy levels, the higher is the input resolution.
- ❖ The fuzzy controller utilizes triangular membership functions on the controller input. The triangular membership function is chosen due to its simplicity. For a given crisp input, fuzzifier finds the degree of membership in every linguistic variable.
- ❖ Since there are only two overlapping memberships in this specific case, all linguistic variables except two will have zero membership.

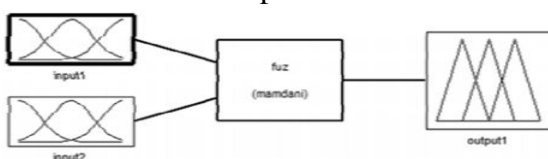

Fig.4. Block diagram of the Fuzzy Logic Controller (FLC)

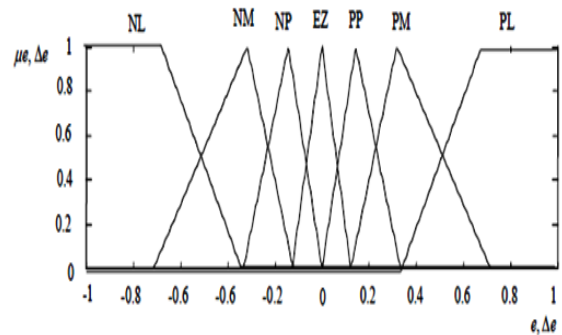

Fig.5. Membership functions for Input, Change in input, Output.

Rule Base: the elements of this rule base table are determined based on the theory that in the transient state, large errors need coarse control, which requires coarse in-put/output variables; in the steady state, small errors need fine control, which requires fine input/output variables. Based on this the elements of the rule table are obtained as shown in Table 1, with ‘Vdc’ and ‘Vdc-ref’ as inputs.

- When the output of the converter is far from the set point, the change of duty cycle must be large so as to bring the output to the set point quickly.
- When the output of the converter is approaching the set point, a small change of duty cycle is necessary.
- When the output of the converter is near the set point and is approaching it rapidly, the duty cycle must be kept constant so as to prevent overshoot.
- When the set point is reached and the output is still changing, the duty cycle must be changed a little bit to prevent the output from moving away.
- When the set point is reached and the output is steady, the duty cycle remains unchanged. When the output is above the set point, the sign of the change of duty cycle must be negative, and vice versa.

Δe \ e	NL	NM	NS	EZ	PS	PM	PL
NL	NL	NL	NL	NL	NM	NS	EZ
NM	NL	NL	NL	NM	NS	EZ	PS
NS	NL	NL	NM	NS	EZ	PS	PM
EZ	NL	NM	NS	EZ	PS	PM	PL
PS	NM	NS	EZ	PS	PM	PL	PL
PM	NS	EZ	PS	PM	PL	PL	PL
PL	NL	NM	NS	EZ	PS	PM	PL

V.MATLAB/SIMULATION RESULTS

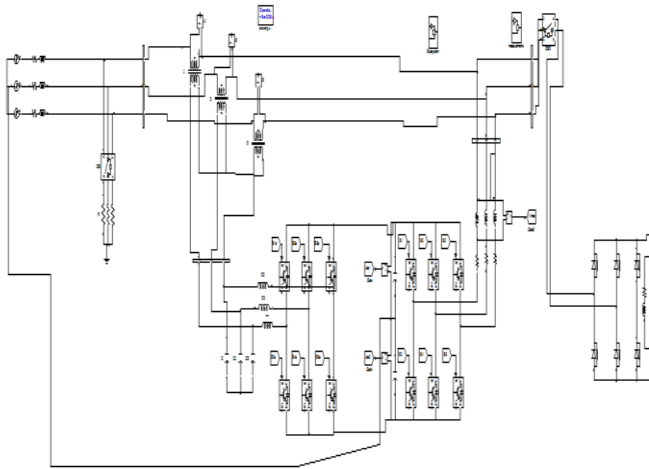

Fig 6 Matlab/simulation circuit for conventional method of iUPQC

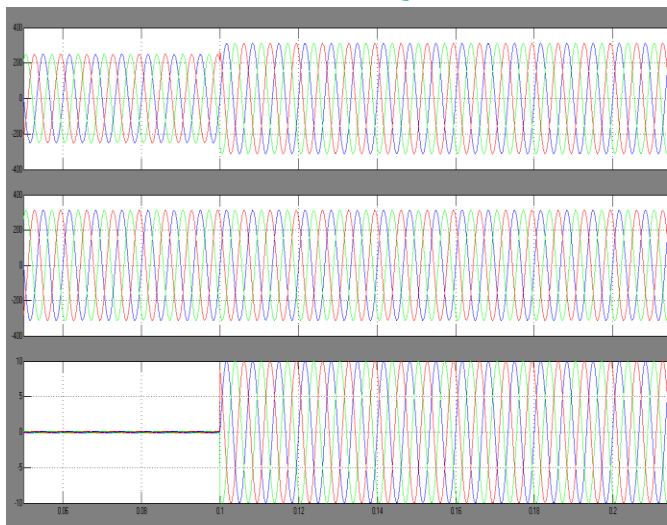

Fig. 7. iUPQC response at no load condition: (a) grid voltages VA, (b) load voltages VB, and (c) grid currents.

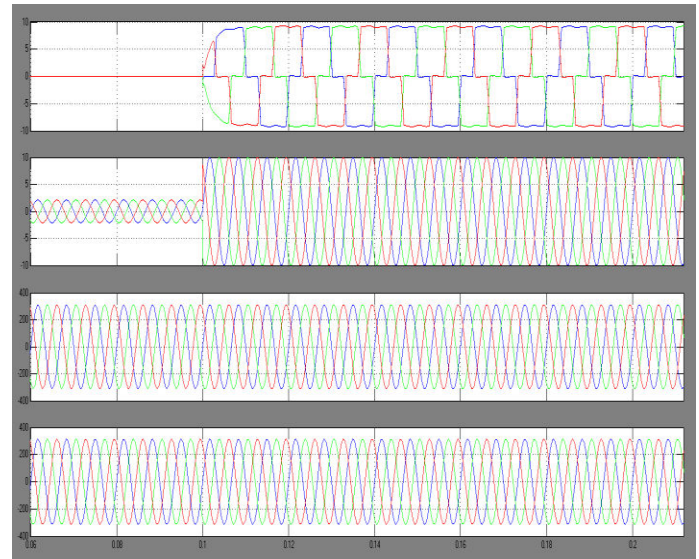

Fig. 8. iUPQC transitory response during the connection of a three phase diode rectifier: (a) load currents, (b) grid currents, (c) load voltages and (d) grid voltages.

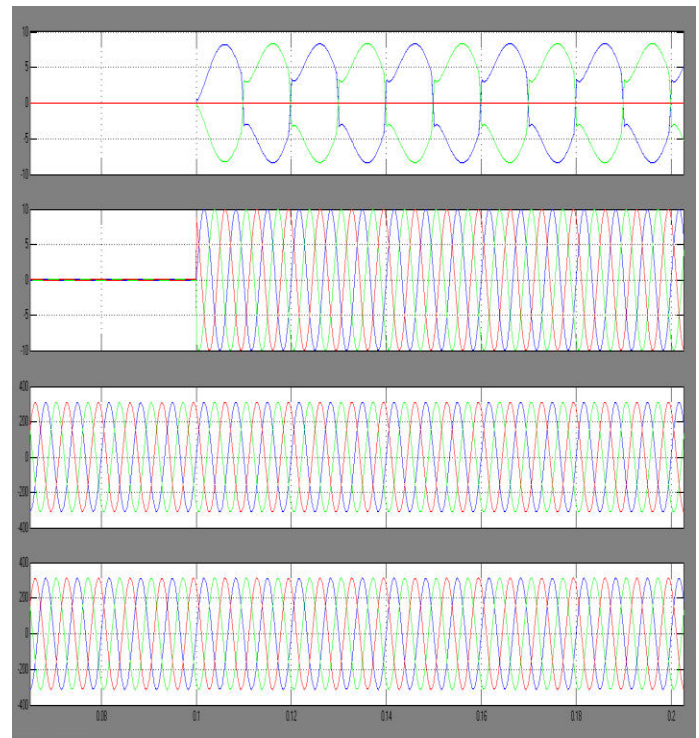

Fig. 9. iUPQC transitory response during the connection of a two phase diode rectifier: (a) load currents, (b) source currents, (c) load voltages, and (c) source voltages.

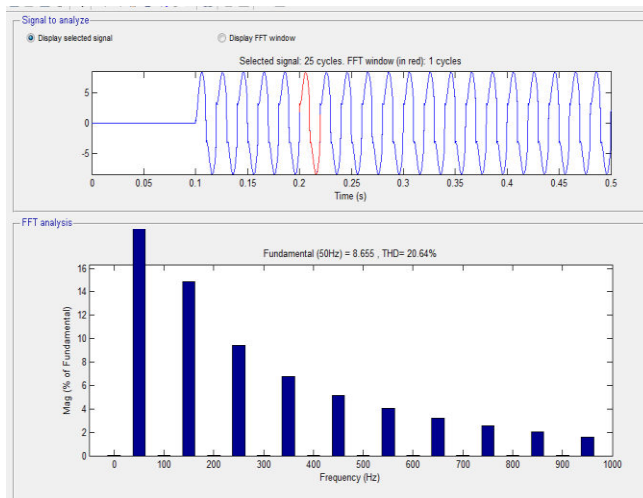

Fig.10.TH D for PI Controller

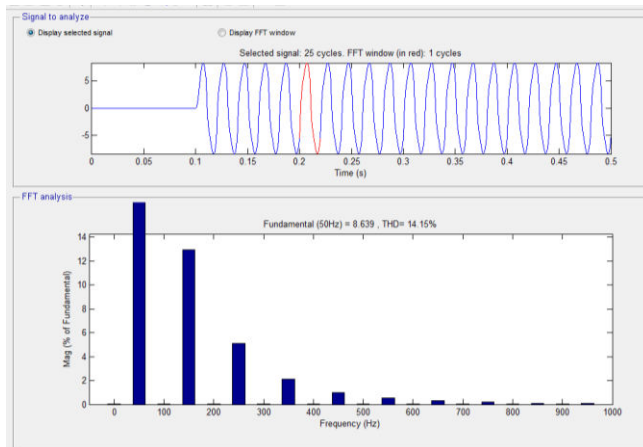

Fig.11.TH D for Fuzzy logic Controller

VI.CONCLUSION

The paper evaluates the operation and control of an interline unified power quality conditioner(IUPQC).By using fuzzy logic control to improved iUPQC controller, the currents synthesized by the series converter are determined by the average active power of the load and the active power to provide the dc-link voltage regulation, together with an average reactive power to regulate the grid-bus voltage. In addition to all the power-quality compensation features and fuzzy logic of a conventional UPQC or an iUPQC, this improved controller also mimics a STATCOM to the grid bus. This new feature enhances the

applicability of the iUPQC and provides new solutions in future scenarios involving smart grids and micro grids, including distributed generation and energy storage systems to better deal with the inherent variability of renewable resources such as solar and wind power. Despite the addition of one more power-quality compensation feature, the grid-voltage regulation reduces the inner-loop circulating power inside the iUPQC, which would allow lower power rating for the series converter. Moreover, the improved iUPQC controller may justify the costs and promotes the Iupqc applicability in power quality issues of critical systems, where it is necessary not only an iUPQC or a STATCOM, but both, simultaneously. These results have demonstrated a suitable performance of voltage regulation at both sides of the iUPQC, even while compensating harmonic current and voltage imbalances. Despite the addition of one more power-quality compensation feature, the grid-voltage regulation reduces the inner-loop circulating power inside the iUPQC, which would allow lower power rating for the series converter. The simulation results verified the improved iUPQC goals.

REFERENCES

- [1] K. Naga Vara Prasad, Dr. Ch. PadmanabhaRaju, "Power Quality Improvement with iUPQC using Fuzzy Logic Controller", IJSETR ISSN 2319-8885 Vol.06,Issue.01 January-2017.
- [2] A. Mokhtatpour and H. A. Shayanfar, "Powerquality compensation as well as power flow controlusing of unified power quality conditioner," in Proc.APPEEC, 2011, pp. 1–4.
- [3] J. A. Munoz et al., "Design of a discrete-timeliner control strategy for a multicell

UPQC,” *IEEE Trans. Ind. Electron.*, vol. 59, no. 10, pp. 3797–3807, Oct. 2012.

[4] V. Khadkikar and A. Chandra, “UPQC-S: A novel concept of simultaneous voltage sag/swell and load reactive power compensations utilizing series inverter of UPQC,” *IEEE Trans. Power Electron.*, vol. 26, no. 9, pp. 2414–2425, Sep. 2011.

[5]. S. Chakraborty, M. Weiss, and M. Simoes, “Distributed intelligent energy management system for a single-phase high-frequency ac microgrid,” *IEEE Trans. Ind. Electron.*, vol. 54, no. 1, pp. 97–109, Feb. 2007.

[6] K. H. Kwan, P. L. So, and Y. C. Chu, “An output regulation-based unified power quality conditioner with Kalman filters,” *IEEE Trans. Ind. Electron.*, vol. 59, no. 11, pp. 4248–4262, Nov. 2012.

[7] V. Khadkikar and A. Chandra, “UPQC-S: A novel concept of simultaneous voltage sag/swell and load reactive power compensations utilizing series inverter of UPQC,” *IEEE Trans. Power Electron.*, vol. 26, no. 9, pp. 2414–2425, Sep. 2011.

[8] M. Aredes and R. M. Fernandes, “A dual topology of unified power quality conditioner: The iUPQC,” in *Proc. EPE Conf. Appl.*, 2009, pp. 1–10.

[9] M. Aredes and R. M. Fernandes, “A unified power quality conditioner with voltage sag/swell compensation capability,” in *Proc. COBEP*, 2009, pp. 218–224.

[10] R. J. Millnitz dos Santos, M. Mezaroba, and J. C. da Cunha, “A dual unified power quality conditioner using a simplified control technique,” in *Proc. COBEP*, 2011, pp. 486–493.

[11] J. J. Sanchez-Gasca, N. W. Miller, E. V. Larsen, A. Edris, and D. A. Bradshaw, “Potential

benefits of STATCOM application to improve generation station performance,” in *Proc. IEEE/PES Transmiss. Distrib. Conf. Expo.*, 2001, vol. 2, pp. 1123–1128.

[12] A. P. Jayam, N. K. Ardesna, and B. H. Chowdhury, “Application of STATCOM for improved reliability of power grid containing a wind turbine,” in *Proc. IEEE Power Energy Soc. Gen. Meet.—Convers. Del. Elect. Energy 21st Century*, 2008, pp. 1–7.

[13] C. A. Sepulveda, J. A. Munoz, J. R. Espinoza, M. E. Figueroa, and P. E. Melin, “All-on-Chip dq-Frame Based D-STATCOM Control Implementation in a Low-Cost FPGA,” *IEEE Trans. Ind. Electron.*, vol. 60, no. 2, pp. 659–669, 2013.

[14] B. Singh and S. R. Arya, “Back-Propagation Control Algorithm for Power Quality Improvement Using DSTATCOM,” *IEEE Trans. Ind. Electron.*, vol. 61, no. 3, pp. 1204–1212, 2014.

[15] M. Aredes and R. M. Fernandes, “A dual topology of Unified Power Quality Conditioner: The iUPQC,” in *Power Electronics and Applications, 2009. EPE '09. 13th European Conference on*, 2009, pp. 1–10.

[16] M. Aredes and R. M. Fernandes, “A unified power quality conditioner with voltage SAG/SWELL compensation capability,” in *Power Electronics Conference, 2009. COBEP '09. Brazilian*, 2009, pp. 218–224.

Authors profile:



B. GOPI received B.Tech degree in Electrical and Electronics Engineering from KLR College of Engineering & Technology, Paloncha, Khammam, T.S. And currently pursuing M.Tech in Power Electronics

& Electrical Drives at KLR College of Engineering & Technology, Paloncha, Bhadradi Kothagudem, T.S. My areas of interest are Power Systems, and control systems, Electrical Machine

V.NARESH KUMAR Working as Assistant Professor in Electrical and Electronics Engineering at KLR College of Engineering & Technology, Paloncha, Khammam, T.S, He



received the B.Tech Degree in Electrical and Electronics Engineering from Adams Engineering College, Paloncha, JNTUH, T.S, and he received P.G. In Electrical and Electronics Engineering

as Electrical Power Systems is Specialization at Abdulkalam Institute of Technological Sciences, Kothagudem, Khammam, T.S, He has a Teaching Experience of 5 years. His Areas of Interest are Power Systems, Control systems and Electrical Machines