



# International Journal for Innovative Engineering and Management Research

A Peer Reviewed Open Access International Journal

www.ijiemr.org

## COPY RIGHT

**2017 IJIEMR.** Personal use of this material is permitted. Permission from IJIEMR must be obtained for all other uses, in any current or future media, including reprinting/republishing this material for advertising or promotional purposes, creating new collective works, for resale or redistribution to servers or lists, or reuse of any copyrighted component of this work in other works. No Reprint should be done to this paper, all copy right is authenticated to Paper Authors

IJIEMR Transactions, online available on 30<sup>th</sup> Aug 2017. Link

[:http://www.ijiemr.org/downloads.php?vol=Volume-6&issue=ISSUE-7](http://www.ijiemr.org/downloads.php?vol=Volume-6&issue=ISSUE-7)

Title: **VOLTAGE QUALITY IMPROVEMENT USING Z-SOURCE INVERTER DVR WITH UNBALANCED VOLTAGE SAG/SWELL BASED ON FUZZY CONTROLLER**

Volume 06, Issue 07, Pages: 461 – 469.  
Paper Authors

**T.MOULALI, M.VINOD KUMAR, R.SURESH BABU**

J.B Institute of Engineering & Technology, Yenkapally; R.R (Dt); Telangana, India.



USE THIS BARCODE TO ACCESS YOUR ONLINE PAPER

To Secure Your Paper As Per **UGC Guidelines** We Are Providing A Electronic Bar Code

## VOLTAGE QUALITY IMPROVEMENT USING Z-SOURCE INVERTER DVR WITH UNBALANCED VOLTAGE SAG/SWELL BASED ON FUZZY CONTROLLER

<sup>1</sup>T.MOULALI, <sup>2</sup>M.VINOD KUMAR, <sup>3</sup>R.SURESH BABU

<sup>1</sup>M-tech Student Scholar Department of E.E.E,J.B Institute of Engineering & Technology, Yenkapally; R.R (Dt); Telangana, India.

<sup>2</sup>Assistant Professor Department of E.E.E,J.B Institute of Engineering & Technology, Yenkapally; R.R (Dt); Telangana, India.

<sup>3</sup>H.O.D M.Tech Associate Professor Department of E.E.E,J.B Institute of Engineering & Technology, Yenkapally; R.R (Dt); Telangana, India.

<sup>1</sup> moulali.eee@gmail.com, <sup>2</sup>vinodmondi@gmail.com, <sup>3</sup>sbrega123@gmail.com

**ABSTRACT-** The power quality requirement is one of the major issues for power companies and their customers. The analysis of power disturbance characteristics and finding solution to the power quality problems have resulted in an increased interest for power quality. The most concerning disturbances affecting the quality of the power in the distribution system are balanced and unbalanced voltage sag/swell. The DVR is used to mitigate the both balanced and unbalanced voltage sag/swell on sensitive load. In this project Z-source inverter (ZSI) based DVR is proposed to enhance the voltage restoration property of the system. The ZSI uses an LC impedance grid to couple power source to inverter circuit and prepares the possibility of voltage buck and boost by short circuiting the inverter legs. Additionally a fuzzy logic control scheme for Z-source inverter based DVR is proposed to obtain desired injecting voltage. Modeling and simulation of the proposed DVR is implemented in MATLAB/SIMULINK platform.

Keywords— Dynamic voltage restorer, Power quality, fuzzy Controller, Z-source inverter.

### I.INTRODUCTION

Power quality is a comprehensive term that squeezes all features related with amplitude, phase and frequency of the voltage and current waveforms existing in a power circuit. Poor power quality may result either from transient conditions accumulate in the power circuit or from the installation of non-linear loads. Due to the advent of a large

numbers of sophisticated electrical and electronic equipments, such as computers, programmable logic, electrical drives etc., power quality problems like voltage sag, voltage swell and harmonic distortion can cause serious problems to industrial and commercial electrical consumers[1,2].For example, some special facilities are sensitive to voltage disturbances. Therefore, in such

cases using compensator for the sensitive loads is necessary. There are some solutions to these problems. Installation of Dynamic Voltage Restorer (DVR) for sensitive loads can be considered as a solution [1–3]. DVR is a custom power device, which is connected to the load through a series transformer. To compensate voltage disturbances, series voltage is injected through the transformer by a voltage-source converter connected to a dc power source [1, 2]. The first DVR was installed in North Carolina, for the rug manufacturing industry. Another was installed to provide service to a large dairy food processing plant in Australia [4]. A DVR consists of a voltage-source inverter, a series-connected injection transformer, an inverter output filter, and an energy-storage device that is connected to the dc link [1–5]. The voltage-source converter is a power electronic device, which can generate a sinusoidal voltage with any required magnitude, frequency and phase angle. This device employs insulated gate bipolar transistors (IGBT) as switches [5].

main functions of the injection transformer include voltage boost and electrical isolation [6]. The DC side of the converter is connected to a DC energy-storage device. Energy-storage devices, such as batteries or super-conducting magnetic energy-storage systems (SMES) are required to provide active power to the load when voltage sags occur [7]. In this paper, battery is used as a source of the DC voltage for the VSC. The output of the inverter (before the transformer) is filtered by Passive filters in order to reject the switching harmonic components from the injected voltage [5]. A typical DVR connected to the distribution system is shown in Fig. 1. Different control strategies were proposed for DVR. Voltage-Space Vector PWM was implemented in [8]. Estimation of symmetrical components of voltage to control DVR is used in [9]. Hysteresis voltage control can be adopted to improve voltage quality of sensitive loads [2, 10]. In this paper, a DVR with a new inverter topology is presented to suppress the load harmonics and to compensate the voltage disturbances. The adopted voltage-source inverter is based on an asymmetrical inverter leg to achieve five voltage levels in output voltage. This inverter has less voltage harmonics generated on the ac terminal of the inverter compared with two-level PWM operation. In the adopted inverter, on the contrary of conventional inverter, no flying capacitor and clamped diode are used in the circuit configuration. The adopted control scheme is fuzzy logic controller based on hysteresis method.

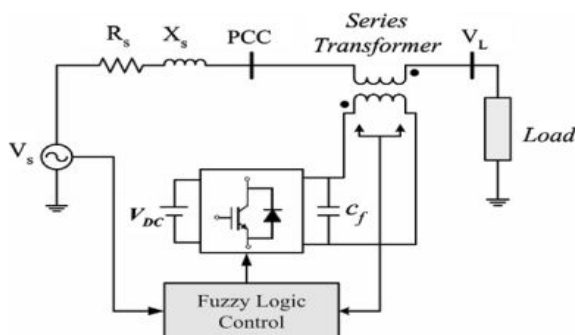

Fig. 1. Typical DVR circuit topology

This converter injects a dynamically controlled voltage in series with the supply voltage through the three single-phase transformers to correct the load voltage. The

## II. METHODOLOGY

The proposed methodology is given in flow chart (Fig.2), which starts from power quality identification, the appropriate device to improve the quality of power followed by DVR and fuzzy controller design and analysis. Finally the comparison of results is proposed.

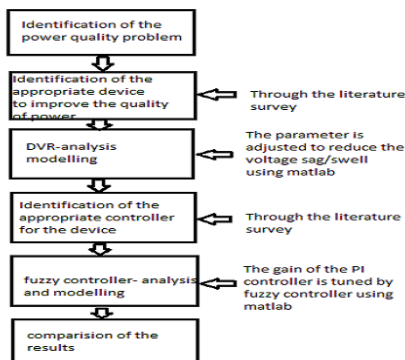

Fig.2: Flow chart for the methodology used

## III. FUZZY LOGIC CONTROLLER

The fuzzy logic controller unlike conventional controllers does not require a mathematical model of the system process being controlled. However, an understanding of the system process and the control requirements is necessary. The fuzzy controller designs must define what information data flows into the system (control input variable), how the information data is processed (control strategy and decision) and what information data flows out of the system (solution output variables) [16]. In this study, a fuzzy logic based feedback controller is employed for controlling the voltage injection of the proposed dynamic voltage restorer (DVR). Fuzzy logic controller is preferred over the conventional PI and PID controller because of its robustness to system parameter variations during operation and its simplicity

of implementation [17]. The proposed FLC scheme exploits the simplicity of the mamdani type fuzzy systems that are used in the design of the controller and adaptation mechanism.

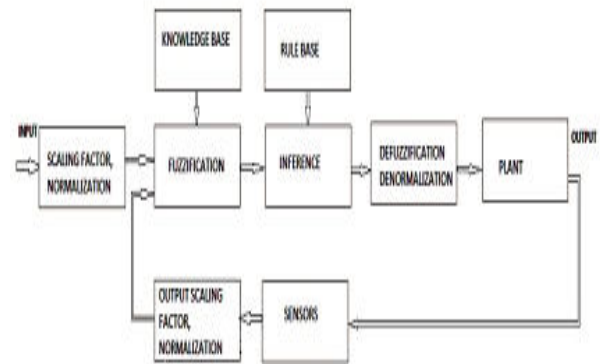

Fig.4: Fuzzy logic controller

The fuzzy logic control scheme (shown in Fig.7) can be divided into four main functional blocks namely knowledge base, fuzzification, inference mechanism and defuzzification. The knowledge base is composed of database and rule base. Data base consists of input and output membership functions and provides information for appropriate fuzzification and defuzzification operations. The rule base consists of a set of linguistic rules relating the fuzzified input variables to the desired control actions. Fuzzification converts a crisp input voltage signals, error voltage signal ( $e$ ) and change in error voltage signal ( $ce$ ) into fuzzified signals that can be identified by level of memberships in the fuzzy sets. The inference mechanism uses the collection of linguistic rules to convert the input conditions of fuzzified outputs to crisp control conditions using the output

membership function, which in the system acts as the changes in the control input ( $u$ ).

Table 1

Rule base for fuzzy logic controller

$e'$ \ $ce'$	NB	NM	NS	ZE	PS	PM	PB
NB	NB	NB	NB	NB	NM	NS	ZE
NM	NB	NB	NB	NM	NS	ZE	PS
NS	NB	NB	NM	NS	ZE	PS	PM
ZE	NB	NM	NS	ZE	PS	PM	PB
PS	NM	NS	ZE	PS	PM	PB	PB
PM	NS	ZE	PS	PM	PB	PB	PB
PB	ZE	PS	PM	PB	PB	PB	PB

## IV. CONVENTIONAL PI CONTROLLER

PI controller is a feedback controller which drives the plant to be controlled with a weighted sum of the error and the integral of that value. The proportional response can be adjusted by multiplying the error by constant  $K_P$ , called proportional gain. The contribution from integral term is proportional to both the magnitude of error and duration of error. The error is first multiplied by the integral gain,  $K_i$  and then was integrated to give an accumulated offset that have been corrected previously. The voltage sag is detected by measuring the error between the  $dq$  voltage and the reference values. The  $d$ -reference is set to rated voltage while  $q$ -reference is set to zero. The  $dq$  components of load voltage are compared with the reference values and the error signal is then fed to PI controller. Two PI controller block are used for error signal  $-q$  respectively. For error signal  $-d$ ,  $K_p$  is set to 40 and  $K_i$  is set to 154 while for error signal  $-q$ ,  $K_p$  and  $K_i$  are set to 25 and 260

respectively. All the gains selected use to tune up the error signal ' $d$ ' and ' $q$ ' so that the signal is stable and well responses to system disturbances. The output of the PI controller are then transformed back to  $V_{abc}$  and then fed to PWM generator.

## V. DYNAMIC VOLTAGE RESTORER

A power electronic converter based series compensator that can protect the critical loads from all the supply side disturbances other than outages is called dynamic voltage restorer. This device employs solid state power electronic switches in the inverter structure.

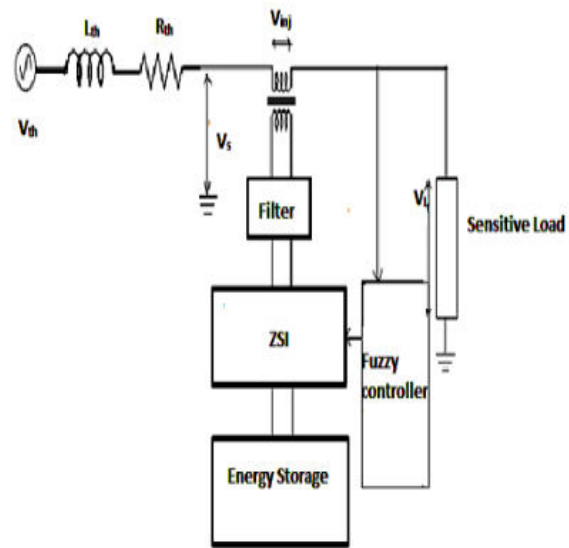

Fig.5. DVR general configuration

It injects a set of three phase AC output voltage in series and synchronism with the distribution feeder voltages. The DC input terminal of the restorer is connected to an energy storage device of appropriate capacity [11, 12]. The DVR consists of the following major components which includes Z-source inverter, injection transformer, harmonic filter, energy storage device as shown in Fig.4.

## A. Injection Transformer:

The injection transformer is connected in series with the sensitive load which is to be protected by the DVR. The basic function of this transformer is to connect the DVR to the distribution system and the injected voltages generated by the inverter are introduced into the distribution system.

## B. Filter:

The main task of the filter is to keep the harmonic voltage content generated by the inverter within the permissible (i.e. it eliminates high frequency switching harmonics) level.

## C. Z-Source Inverter:

Z-Source inverter are the buck-boost inverters that contain unique passive input circuits (impedance networks) and utilize the shoot-through of the inverter bridge to boost the DC input voltage.

## D. Energy Storage Device:

It provides the real power requirement of the DVR during compensation. It is responsible for the energy storage in DC form. Flywheels, lead acid batteries, superconducting magnetic energy storage (SMES) and super capacitors can be used as energy storage devices. Here in the form of DC supply from the energy storage system is given to the inverter.

## E. Basic Operation Of DVR:

The basic operating principle of DVR is to inject proper series voltage to the grid in order to restore the load voltage level to its desired level.

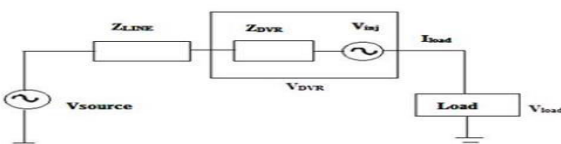

Fig.6 Equivalent circuit

As shown in Fig. 5 the Z- impedances  $Z_{th}$  depends on the fault level of load bus. When the system voltage  $V_{th}$  drops, DVR injects the series voltage  $V_{DVR}$  through the injection transformer so that the desired voltage magnitude  $V_L$  can be maintained. The series injected voltage of DVR can be written as

$$V_{DVR} = V_L + Z_{th} I_L - V_{th} \quad (2)$$

$V_L$ : Desired load voltage magnitude

$Z_{th}$ : Desired load impedance

$I_L$ : Desired load current

$V_{th}$ : System voltage during fault condition.

## VI. Z-SOURCE INVERTER

The inverter topology used in conventional DVR is both VSI and CSI. The VSI topology based DVR has buck type output voltage characteristics thereby limiting the maximum voltage that can be attained. Therefore the use of VSI topology alone in DVR systems with dwindling dc-link voltage in the energy storage device would pose a problem. The main disadvantage of CSI topology is it's basically a boost converter. For applications where a wide voltage range is required, extra circuitry has to be used to obtain the required voltage. However, this increases the circuit complexity and reduces the efficiency as well as the reliability [7]-[13]. The Z-source inverter has been an alternative to the existing inverter topologies with many inherent advantages [14]. The Zsource inverter has an additional zero vector, the shoot-through switching state, which is forbidden in the traditional voltage and current source inverter [15]. Compared to

VSI and CSI, Zsource inverter is less affected by the EMI noise In this paper, voltage type Z-source inverter based topology is proposed where the storage device can be utilized during the process of load compensation along with the use of buck boost property of the inverter. A series diode is connected between the source and impedance network, which is required to protect the source from a possible current flow. The impedance network is the combination of two inductors and capacitors.

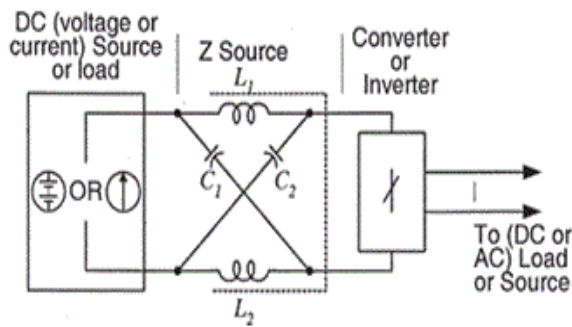

Fig 7 Basic Z-source inverter

This combination network circuit is the energy storage are filtering element for the impedance source inverter. The impedance source inverter provides the second order filter. This is more effective to suppress voltage and current ripples. The inductor and capacitor requirement should be smaller compared to the traditional inverter [14]. When the inductors are small and approach zero, the impedance source network reduces to two capacitors in parallel and becomes traditional voltage source. Considering additional filtering and energy storage provided by the inductors, the impedance source network should require less capacitance smaller size compare with the traditional voltage source inverter.

## VII.MATLAB/SIMULINK RESULTS

The proposed power system consists of a three phase 440V/50Hz supply feeding two or more loads through distribution lines. A sudden three phase to ground fault generated in the system results in decrease in voltage. The above problem can be avoided by using load side compensation of DVR using Z – source inverter with PI and fuzzy controller.

*Case i: Voltage Sag Compensation Using DVR with Pi and fuzzy logic controller*

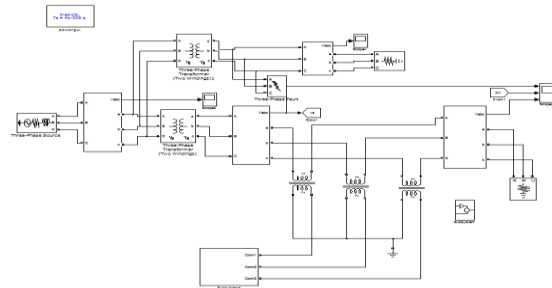

Fig.8 Matlab/Simulink Model of Proposed Voltage Compensation Scheme Operated By Using PI & Fuzzy Control

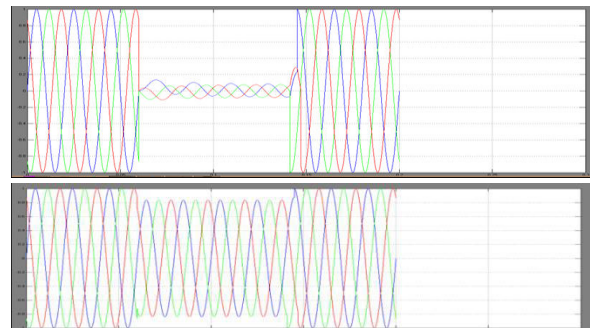
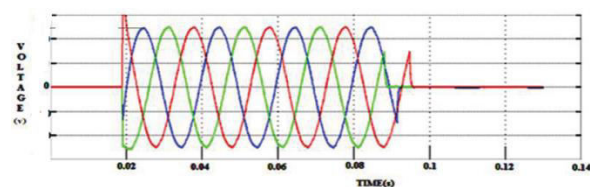

Fig.9: Three phase voltage at load point during three phase fault without DVR



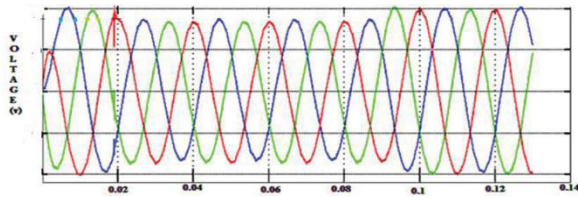

Fig. 10: Three phase voltage at load point during three phase fault with DVR and PI controller

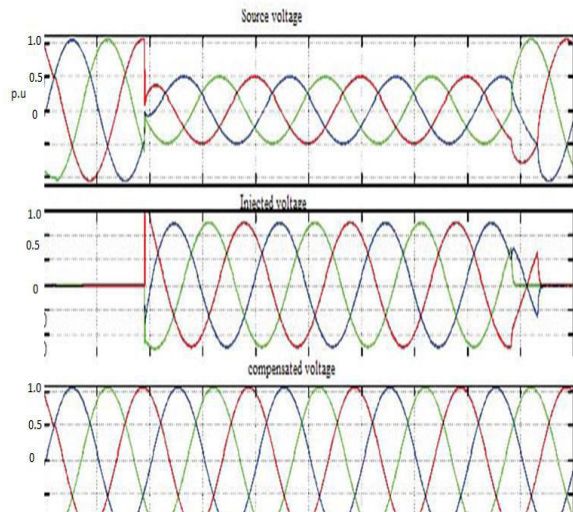
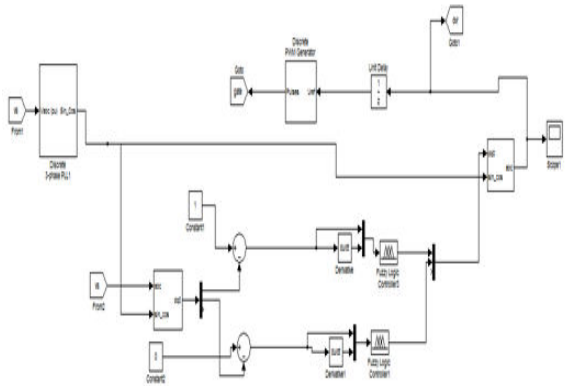

Fig. 12: Three Phase voltage at load point during three phase fault with DVR and Fuzzy controller.

Case ii: Voltage Compensation Using DVR For Z-Source Inverter With Unbalanced Sag and Swell Condition

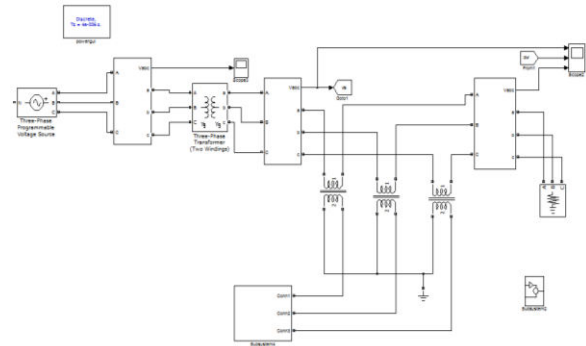

Fig 13. Matlab/Simulink circuit of DVR for z-source inverter Unbalanced sag condition

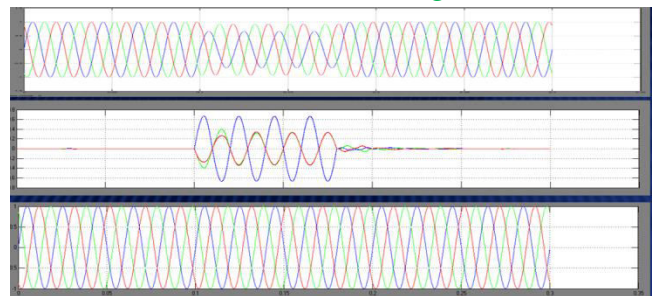

Fig 14 the phase voltage waveform of DVR with Z-source inverter under Unbalanced sag

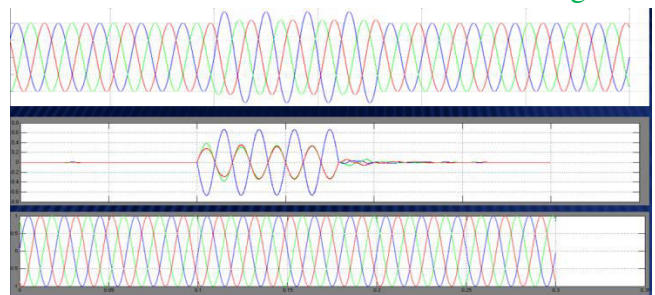

Fig 15 the phase voltage waveforms of DVR with Z-source inverter under Unbalanced swell.

## VIII CONCLUSION

DVR serves as an effective custom power device for mitigating voltage sag/swell in the distribution system. In case of external disturbances the proposed DVR injects appropriate voltage component to dynamically correct any deviation in supply voltage in order to maintain balanced and constant load voltage at nominal value. In this project DVR along with the Z-Source



inverter to compensate the voltage sag in the distribution system with the conventional PI controller. The fuzzy controller is used with the Z-source based DVR for the compensation of voltage sag in the distribution system and also tested for unbalanced sag and swell conditions. The simulation is carried out in MATLAB/SIMULINK along with the fuzzy logic tool box and the result is better compared with the PI controller.

## REFERENCES

- [1] P. Boonchiam, N. Mithulanathan, Dynamic control strategy in medium voltage DVR for mitigating voltage sags/swells, in: International Conference on Power System Technology, 2006, pp. 1–5.
- [2] H. Ezoji, A. Sheikholeslami, M. Tabasi, M.M. Saeednia, Simulation of Dynamic Voltage Restorer using hysteresis voltage control, European Journal of Scientific Research (EJSR) 27 (1) (2009) 152–166.
- [3] M.R. Banaei, S.H. Hosseini, S. Khanmohamadi, G.B. Gharehpetian, Verification of a new energy control strategy for Dynamic Voltage Restorer by simulation, ELSEVIER Simulation Modeling Practice and Theory 14 (2006) 113–125.
- [4] A. Ghosh, G. Ledwich, Compensation of distribution system voltage using DVR, IEEE Transactions on Power Delivery 17 (4) (2002) 1030–1036.
- [5] P.T. Nguyen, T.K. Saha, Dynamic Voltage Restorer against balanced and unbalanced voltage sags: modeling and simulation, IEEE Transactions on Power Delivery (2004) 1–6.
- [6] K.A. Ramasamy, R.K. Iyer, V.K. Ramachandaramuthy, R.N. Mukerjee, Dynamic Voltage Restorer for voltage sag compensation, in: IEEE International Conference on Power Electronics and Drive Systems, (PEDS), 2005, pp. 1289–1294.
- [7] M.A. Hannan, A. Mohamed, Modeling and analysis of a 24-pulse Dynamic Voltage Restorer in a distribution, system research and development, in: SCOReD, 2002, pp. 192–195.
- [8] C. Zhan, V.K. Ramachandaramurthy, A. Arulampalam, C. Fitzler, S. Kromlidis, M. Barnes, N. Jenkins, Dynamic Voltage Restorer based on Voltage-Space Vector PWM control, IEEE Transactions on Industry Applications 34 (6) (2001) 1855–1863.
- [9] M.I. Marei, E.F. El-Saadany, M.M.A. Salama, A new approach to control dVDR based on symmetrical components estimation, IEEE Transactions on Power Delivery 22 (1) (2007) 2017–2024.
- [10] F. Al Jowder, Modeling and simulation of Dynamic Voltage Restorer (DVR) based on hysteresis voltage control, in: IEEE Conference on Industrial Electronics Society (IECON), 2007, pp. 1726–1731.
- [11] G. K. Singh, A. K. Singh and R. Maitra, “A simple fuzzy logic based robust active power filter for harmonics minimization under random load variation” EPSR, Elsevier Publ, Vol. 77, 8, pp. 1101 – 1111, Yr-2007
- [12] S. K. Jain, P. Agrawala and H.O. Gupta, “Fuzzy logic controlled shunt active filter for power quality improvement,” IEEE proceedings of EPS., vol. 149, no.7, pp. 317-328, 2002.
- [13] S. Torabzad, E. Badaei, M. Kalantari “Z-source Inverter based dynamic voltage

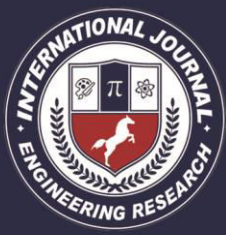

restorer” 1stPower electronics& Drive systems & Technologies Conference IEEE 2010 Zhe Chen, Senior member, IEEE, Josep M. Guerrero, senior member, IEEE, and Frede Blaabjerg, Fellow, IEEE” A review of the state of the art of power electronics for wind turbines” IEEE trans on power electronics, vol.24,No. 8, August 2009, pp. 1859-1875.

[14] P. C. Loh, D. M. Vilathgamuwa, Y. s. Lai, G. T. Chua, and Y. Li, “ voltage sag compensation with Z –Source inverter based dynamic voltage restorer” , in industrial applications, volume-5, October 2006.

[15] T. Jimichi, H. Fujita, and H. Akagi, “Design and experimentation of a dynamic voltage restorer capable of significantly reducing an energy storage element”, in conf. Record Industry Applications Conference, 14 thIAS Annual Meeting. 2005.

[16] B. Justus Rabi & R. Arumugam – “Harmonics study & comparison of ZSI with traditional inverters” IEEE Industrial Electronics Society Conference.

[17] B. Ferdi, C. Benachaiba, S. Dib, R. Dehini “ Adaptive PI control of Dynamic Voltage Restorer Using Fuzzy Logic”, Journal of Electrical Engineering: Theory and Application., vol. 1-2010/ Iss.3