



International Journal for Innovative Engineering and Management Research

A Peer Reviewed Open Access International Journal

www.ijiemr.org

COPY RIGHT

2017 IJIEMR. Personal use of this material is permitted. Permission from IJIEMR must be obtained for all other uses, in any current or future media, including reprinting/republishing this material for advertising or promotional purposes, creating new collective works, for resale or redistribution to servers or lists, or reuse of any copyrighted component of this work in other works. No Reprint should be done to this paper, all copy right is authenticated to Paper Authors

IJIEMR Transactions, online available on 16th August 2017. Link :

<http://www.ijiemr.org/downloads.php?vol=Volume-6&issue=ISSUE-6>

Title: Novel Single-Phase Ac–Ac Converters Solving Commutation Problem For Single-Phase Induction Motor Drive Application.

Volume 06, Issue 06, Page No: 92 – 105.

Paper Authors

***¹MALLEPULA ANUSHA, ²G.MOHAN KRISHNA, ³G.RAJESH.**

* Dept of EEE, St Peter's Engineering College, Medchal.



USE THIS BARCODE TO ACCESS YOUR ONLINE PAPER

To Secure Your Paper As Per **UGC Guidelines** We Are Providing A Electronic Bar Code

NOVEL SINGLE-PHASE AC-AC CONVERTERS SOLVING COMMUTATION PROBLEM FOR SINGLE-PHASE INDUCTION MOTOR DRIVE APPLICATION

¹MALLEPULA ANUSHA, ²G.MOHAN KRISHNA, ³G.RAJESH

PG Scholar, Dept of EEE, St Peter's Engineering College, Medchal; 08/08/2017 (Dt); A.P, India.

Assistant Professor, Dept of EEE, St Peter's Engineering College, Medchal; 08/08/2017 (Dt); A.P, India.

Associate Professor, Dept of EEE, St Peter's Engineering College, Medchal; 08/08/2017 (Dt); A.P, India.

ABSTRACT-

This paper proposes a modified single-phase AC-AC converter without commutation problem for single-phase induction motor. The proposed converter has no shoot-through and dead-time problems and, like conventional ac-ac converters, it can be operated with simple phase converter control. It offers high frequency and high efficiency operation because high speed MOSFET can be used as switching device without the reverse recovery issues and losses of system. The proposed converter features input and output currents, high input power factor, low total harmonic distortion of input and output currents, new commutation strategies for these converters are proposed and safe commutation can be achieved without computational circuit problems. The commutation strategies are easily to realize by sampling only voltage signals, and Analysis based on state-space averaging reveals the relationship between induction motor inductor and filter inductor current as well as voltage ratio. The design considerations of single phase AC-AC converter fed single-phase induction motor topology are given as an example. The computational-fed single-phase topology verified the unique features of single phase -source ac-ac converters and the proposed commutation strategies. These converters have merits such as less conduction and switching loss, fewer devices, therefore high reliability can be achieved. The proposed ac-ac converters have no circulating current and do not require bulky coupled inductors; therefore, the total losses, current stresses, and magnetic volume are reduced.

Key words: Commutation, direct pulse width modulation (PWM) ac-ac converter, efficiency, reliability, Induction motor drive.

I. INTRODUCTION

Traditionally in industry, the ac-ac power conversions are performed by using ac thyristor power controllers, which use the phase angle or integral cycle control on input ac voltage, to get the desired output ac voltage [1-2]. However, the obvious disadvantages of ac thyristor controllers such as low power factor, large total

harmonic distortion in source current and lower efficiency, have limited their use [3]. For ac-ac power conversions with variable frequency and voltage, the use of indirect ac-ac converters with dc-link, and matrix converters have been advanced because they can obtain better power factor and efficiency, and smaller filter requirements. However, for applications in which only voltage regulation is needed, the

direct PWM ac-ac converters All of these direct PWM AC - AC converters in are obtained from their dc-dc counterparts, where all the unidirectional switches are replaced with bidirectional devices .However, each topology has its own limitations; the buck type ac-ac converter, can only step-down the input voltage while boost type can only step-up the input voltage. The buck-boost and Cuk topology can both step-up and step-down the input voltage, however, the phase angle is reversed. Moreover, both topologies have disadvantage of higher voltage stress across switches, and there are discontinuous input and output currents in case of the buck-boost converter. The Cuk topology can overcome the currents discontinuity but at the cost of additional passive components; increasing the size and cost of converter and decreasing the efficiency .All of the direct PWM ac-ac converters have a common commutation problem, which occurs because compared to the ideal situation in which the complementary [4].

This AC-AC converter and even DC-DC converter is used to control the speed of induction motor by inverting the output of circuit [5]. In industries AC-AC power converters are generally uses thyristors for power controlling to get desired output voltage. However the main disadvantage is its low power factor and harmonic distortions and low efficiency [6]. For AC-AC conversions with different frequencies and voltages, the use of indirect ac-ac converters with dc-link and matrix converters have been advanced because they can obtain higher power factor and efficiency, and smaller filter requirements [7]. For applications in which only voltage regulation is needed, the direct pulse width

modulation (PWM) AC-AC converters are more preferred because they can reduce the size and cost of converter. All of these direct PWM ac-ac converters in are obtained from their dc-dc counterparts, where all the unidirectional switches are replaced with bidirectional devices. However, each topology has its own limitations. The buck-boost topology can do step up and step down voltages with reversed phase angle .More over this both topologies have disadvantages high voltages stress across switches there are discontinuous input and output currents in case of buck-boost converters.

All of the direct PWM AC-AC converters have a common commutation problem, which occurs because compared to the ideal situation in which the complementary switches do not have any overlap or dead-time; however, practically there exists a small overlap or dead-time owing to different time delays of gating signals and limited speed of switching devices [8]. During the overlap time between complementary switches, either a short-circuit of voltage source (or capacitor) occurs or two capacitors with different voltages become in parallel to each other both of which results in current spikes which may damage the switching devices [9]. During the dead time, there is no current path for the flow of inductor current or two inductors become in series resulting in voltage spikes which may also damage the switching devices. To solve this commutation problem, the PWM dead-times are intentionally added in switching signals to avoid overlap time, and then bulky and lossy RC snubbers are used to protect switching devices from voltage spikes or dedicated Safe-commutation strategies are implemented to

provide continuous inductor current path during dead-time [10]. These PWM dead times not only reduce the quality of output Voltage, but also limit the maximum obtainable voltage gain and switching frequency. In switching cell structure and coupled inductors are used to solve commutation problem in conventional buck, boost and buck–boost converters [11].

These direct PWM ac–ac converters typically employed IGBTs, and therefore, cannot obtain benefits of using MOSFETs (such as low switching loss, resistive conduction voltage drop, and fast switching speed, etc.) because of following reasons; They are hard-switched ac–ac converter, and the body diodes of bidirectional switches also conduct same amount of current as the active switches [12]. Therefore, the poor reverse recovery problem of MOSFETs body diodes prevents their use in these hard-switched ac–ac converters.

To overcome the drawbacks of existing PWM AC-AC converters, a direct AC-AC converter is proposed with inverting buck-boost mode. The proposed converter uses the same number of passive components has single non-inverting buck or boost converter [13]. The proposed converter is immune from shoot-through of voltage source (or capacitors) even when all switches are turned on simultaneously, which enhances its reliability and it does not need PWM dead time which results in high-quality output voltage [14]. Even though it uses six unidirectional current conducting bidirectional voltage blocking switches, only two of them are switched at high frequency in each half-cycle during any operating mode, resulting in smaller switching losses [15]. In the proposed converter, no current flows through body diodes of switches, and therefore,

it uses power MOSFETs with fast recovery diodes in series, which decreases switching losses and poor reverse recovery problem of MOSFETs body diodes is also avoided. The non inverting buck–boost modes of proposed converter are suitable for applications with both step-up and step-down demand while the inverting buck–boost mode can also be utilized in DVR application to compensate both voltage sags and swells.

II. PROPOSED SINGLE-PHASE AC-AC CONVERTERS

The proposed single-phase buck, boost, and buck–boost type ac–ac converters are shown in Fig.2. They are implemented with the P-type and N-type SCs, therefore, they are highly reliable when compared with the traditional ac–ac converters. The two leg capacitors C1 and C2 provide safe path for inductor currents when dead time between S_p and S_n occurs and they also act as regenerative dc snubbers. The inductors L_p and L_n are added to limit the shoot-through current by providing a high impedance path when overlap time between S_p and S_n occurs. They also serve as filter inductors, and therefore the external filter inductor can be minimized or removed.

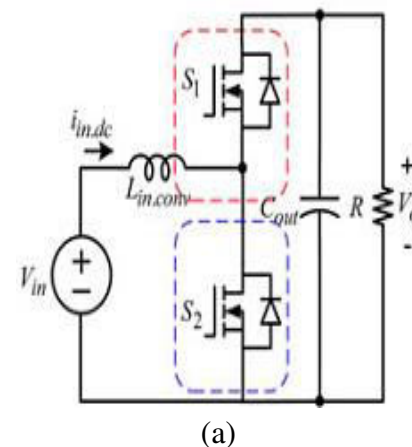

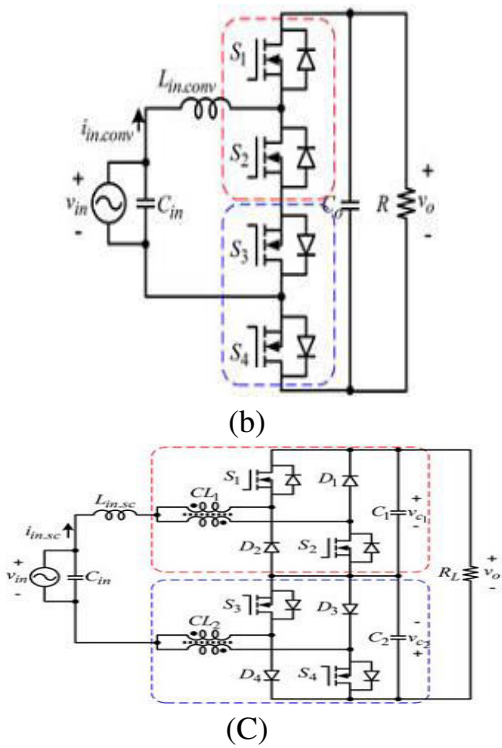

Fig. 1. Boost-type dc-dc and ac-ac direct PWM converters. (a) Traditional dc-dc converter. (b) Traditional ac-ac converter. (c) SC ac-ac converter [13]

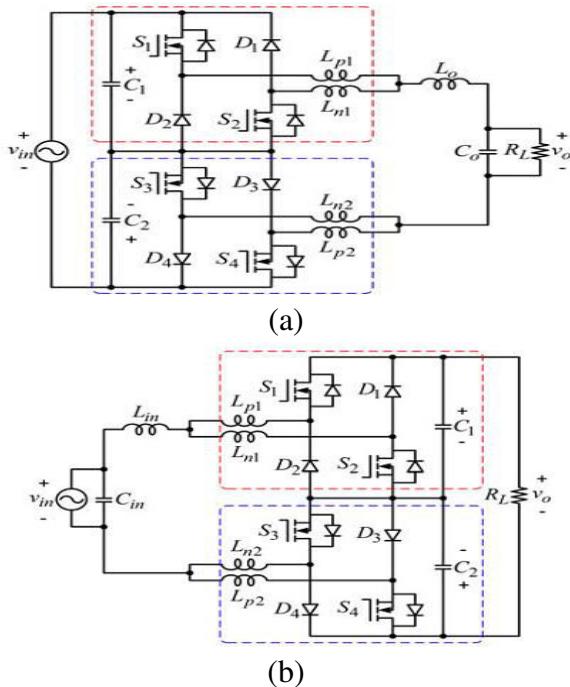
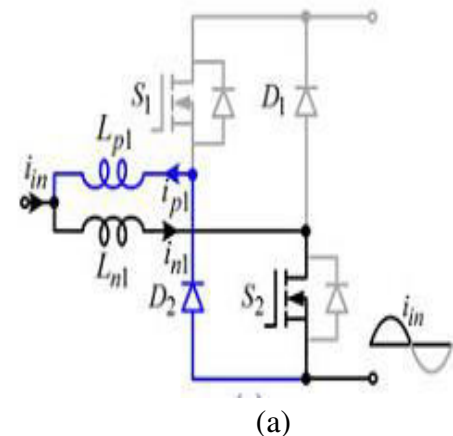

Fig. 2. Proposed single-phase ac-ac converters.

- (a) Buck type.
- (b) Boost type. (c) Buck-boost type.

The gate signals of switches (S1, S4) and (S2, S3) are complementary and are obtained by comparing a carrier signal (V_{tri}) with a control signal (V_{ref}) as shown in Fig.3 (b). This PWM strategy as with the traditional ac-ac converters requires only one carrier signal, whereas the gate signals of the SC ac-ac converters in [13] require two carrier signals out of phase by 180° . The PWM strategy increases the effective frequency experienced by filter inductor of the SC ac-ac converters, therefore the filter inductor size can be minimized [13].



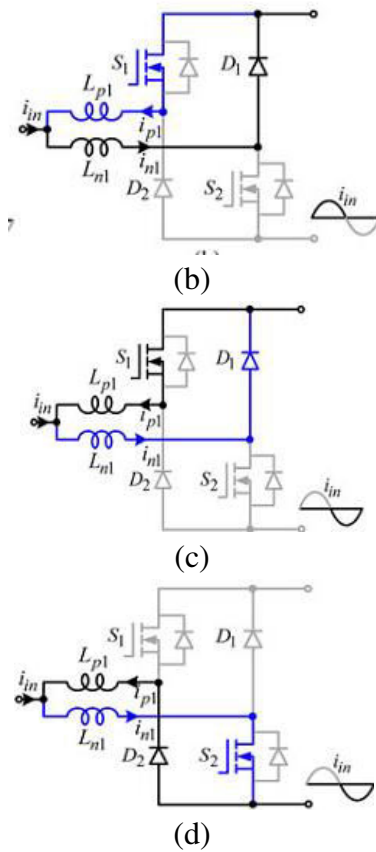

Fig.3. Conduction states of the proposed boost-type ac-ac converter. (a) $i_{in} > 0$ and S_2 on. (b) $i_{in} > 0$ and S_2 off. (c) $i_{in} < 0$ and S_1 on. (d) $i_{in} < 0$ and S_1 off.

III. OPERATION OF THE PROPOSED CONVERTERS

Among the three proposed configurations in Fig.2, the boost type ac-ac converter is presented here. For the sake of simplicity only four limiting inductors without input inductor are considered and similar analysis can be extended to the buck and buck-boost-type converters. Fig.3 shows four conduction states of the proposed converter over one fundamental cycle of input current. To satisfy the flux (volt-sec) balance condition on limiting inductors, the currents through the limiting inductors should flow in the direction

shown in Fig.3; therefore body diodes of the MOSFETs have no chance to flow the current.

Thus, the reverse recovery problem associated with MOSFET body diodes can be resolved and the converters can be operated with high switching frequency. Fig.3 also shows that only two limiting inductors (L_{n1} and L_{p2}) or (L_{n2} and L_{p1}) conduct the input current at a time. The current relationship is as follows:

$$i_{in} = i_{n1} - i_{p1} = i_{p2} - i_{n2} \quad (1)$$

Where i_{in} is the input current and i_{n1} , i_{p1} , i_{n2} , and i_{p2} are the currents of limiting inductors L_{n1} , L_{p1} , L_{n2} , and L_{p2} , respectively. The proposed converters have two consecutive charging and discharging modes as discussed below.

A. Mode 1[0~DTs]

In mode 1, shown in Fig.4, the switches S_2 , S_3 are turned on and S_1 , S_4 are turned off. Thus, D_2 , D_3 become forward biased and D_1 , D_4 become reverse biased. The simplified equivalent circuit model of mode 1 for $v_{in} > 0$ is shown in Fig.4 (c). In this mode, the energy is stored in L_{n1} and L_{p2} . The voltage and current relationships in this mode are as follows:

$$v_{Leq} = v_{in} \quad (2)$$

$$\frac{di_{n1}}{dt} = \frac{v_{Leq}}{L_{eq}} \quad (3)$$

$$L_{eq} = 2L_{np} \quad (4)$$

Where V_{Leq} is the sum of voltages across the limiting inductors (L_{n1} and L_{p2}) or (L_{n2} and L_{p1}), L_{np} is the inductance of each limiting inductor, and L_{eq} is the equivalent inductance seen by the inductor current. Since

L_{n1} and L_{p2} are connected in series, the voltages across L_{n1} and L_{p2} are expressed as

$$v_{L_{n1}} = v_{L_{p2}} = \frac{v_{in}}{2} \quad (5)$$

Where v_{in} is the input voltage. The switches $S1-S4$ are switched at high frequencies; therefore, when $S2, S3$ are turned on, $D2, D3$ become forward biased, and minor current loops shown by brown dotted lines are formed, as depicted in Fig.4. The current in these loops circle back through $D2$ and $D3$.

B. Mode 2 [DTs ~Ts]

In mode 2, shown in Fig.5, the switches $S1, S4$ are turned on, $S2, S3$ are turned off. Thus, $D1, D4$ become forward biased and $D2, D3$ become reverse biased. The equivalent circuit model of mode 2 is shown in Fig.5 (c) for $v_{in} > 0$. In this mode, the stored energy in the inductors is delivered to the output. The current and voltage relationship are as follows:

$$v_{L_{eq}} = v_{in} - v_o \quad (6)$$

$$\frac{di_{n1}}{dt} = \frac{v_{in} - v_o}{L_{eq}} \quad (7)$$

Where v_o is the output voltage. Using the volt-sec balance condition on inductors, the voltage gain of the proposed boost-type ac-ac converter is obtained as

$$\frac{v_o}{v_{in}} = \frac{1}{1 - D} \quad (8)$$

From (8), it is found that the voltage gain of the proposed converter is identical to that of the boost-type SC and traditional boost-type ac-ac converters. In ideal case, the proposed converters have no dead and overlap time in the complementary gate signals. However, delays in response time of gate drive circuits, mismatches in gate signals, non-instantaneous responses of semiconductor devices, and EMI noise can cause overlap or

dead time in practically. These effects are briefly discussed later.

C. Dead Time

The dead time in which all the switching devices are turned off is shown in Fig.6 (a). The capacitors $C1$ and $C2$ bypass the inductors currents during the dead time. The bypass modes for positive and negative half cycle of input voltage are shown in Fig.6 (b) and (c), respectively.

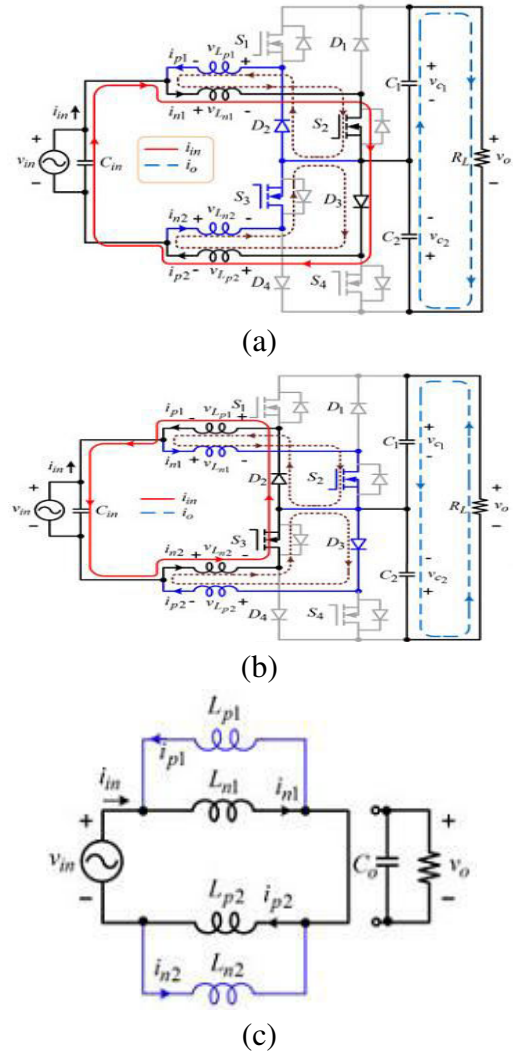

Fig.4. Mode 1 of the proposed boost-type ac-ac converter.

(a) $v_{in} > 0$. (b) $v_{in} < 0$. (c) Simplified equivalent circuit of mode 1 for $v_{in} > 0$.

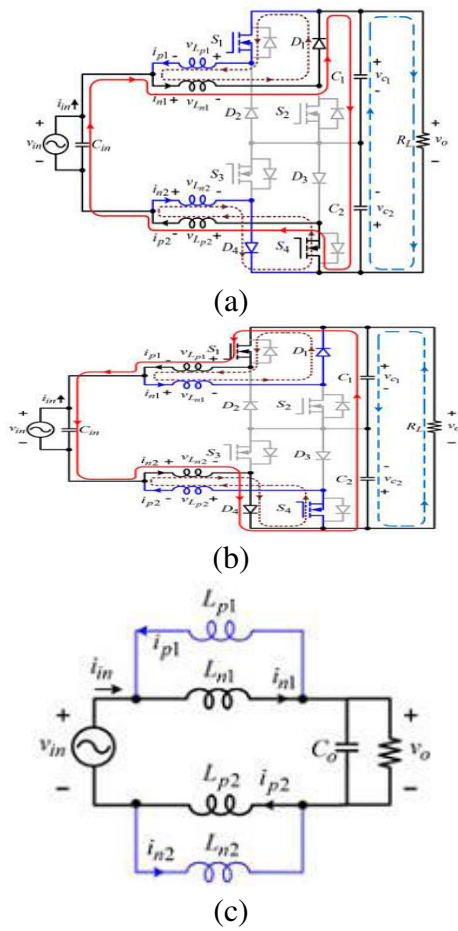

Fig.5. Mode 2 of the proposed boost type ac-ac converter.

(a) $v_{in} > 0$. (b) $v_{in} < 0$. (c) Simplified equivalent circuit of mode 2 for $v_{in} > 0$.

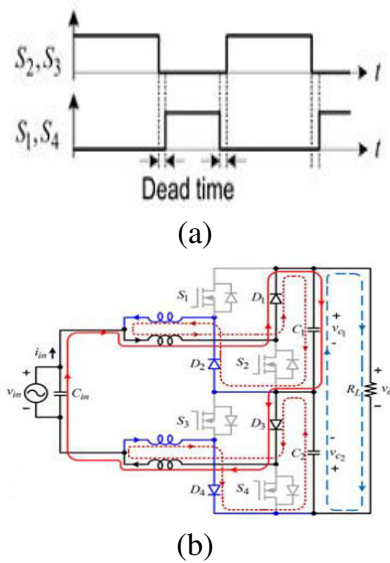
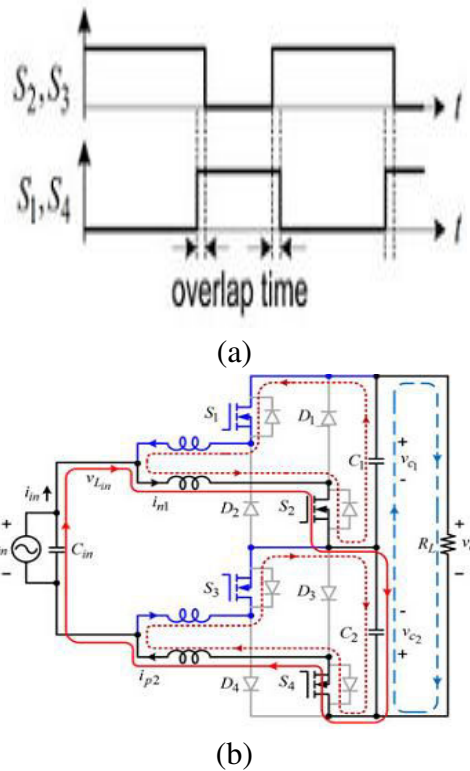

Fig.6. Operation of the proposed boost type ac-ac converter during dead time. (a) Dead time. (b) $v_{in} > 0$. (c) $v_{in} < 0$.

D. Overlap Time

In this interval, all the switching devices are turned on, as shown in Fig.7 (a). The limiting inductors limit the shoot-through current by providing a high impedance path when all the switches are turned on either by purpose or mismatched gate signals. Fig.7 (b) and (c) shows this mode for $v_{in} > 0$ and $v_{in} < 0$, respectively.



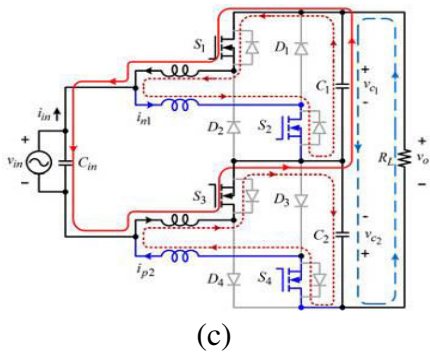

Fig.7. Operation of the proposed boost type ac-ac converter during overlap time. (a) Overlap time. (b) $v_{in} > 0$. (c) $v_{in} < 0$.

IV. INDUCTOR DESIGN AND COMPARISON

The inductor current ripple of the traditional boost-type ac-ac converter $\Delta i_{in.conv}$, as shown in Fig.1 (b), can be obtained as

$$\Delta i_{in.conv} = \frac{(1-D)D}{L_{conv}} v_o T_s \quad (9)$$

Where L_{conv} is the inductance of the input inductor of the traditional ac-ac converter. Using (3), the inductor current ripple of the proposed boost type ac-ac converter Δi_{n1} can be expressed as

$$\Delta i_{n1} = \frac{(1-D)D}{L_{eq}} v_o T_s \quad (10)$$

For the same inductance of limiting inductors, $\Delta i_{n1} = \Delta i_{p1} = \Delta i_{n2} = \Delta i_{p2}$. Thus, for $L_{eq} = L_{conv}$ using (9) and (10), the inductor current ripples of the proposed and traditional ac-ac converters are same; therefore, the switch current stress of the proposed and traditional ac-ac converters are the same. However, the additional circulating current in the SC ac-ac converters causes switch current stresses to be higher than that of the proposed ac-ac converters. If the input inductor of the proposed boost-type ac-ac converter is removed ($L=0$),

and the inductance of each limiting inductor follows $L_{np} = L_{conv}/2$.

Then using (9) and (10), $\Delta i_{in.conv} = \Delta i_{n1}$, and the total inductance of the proposed ac-ac converter becomes twice the inductance of the traditional ac-ac converter. In each operating mode of the proposed converter, two limiting inductors and an input inductor are in series, as shown in Fig. 7; therefore, the volume of each inductor is determined by the corresponding inductance value. Since, the input inductor is common to both phase legs; therefore, if the proposed converter is designed with a large input inductor ($L \sim L_{conv}$) and small limiting inductors ($L_{np} \ll L$), then the total inductance and magnetic volume of the proposed and traditional ac-ac converters can be comparable.

However, the limiting inductors should be designed to attain system reliability, and they can better limit shoot-through current when designed with high inductance and large air gap. Therefore, design of the limiting inductors must compromise between magnetic volume and system reliability.

As derived in [13], the input inductor current ripples $\Delta i_{in.sc}$ of the boost-type SC ac-ac converter shown in Fig.1(c) can be expressed as

$$\Delta i_{in.sc} = \frac{(0.5-D)D}{L_{sc}} v_o T_s \quad (11)$$

Where L_{sc} is the inductance of input inductor of the boost type SC ac-ac converter. For same current ripple, the relation between the inductances of input inductors in traditional and SC ac-ac converters can be derived as in (12) by using (9) and (11) [13]

$$\frac{L_{conv}}{L_{sc}} = \frac{1 - D}{0.5 - D} \quad (12)$$

Equation (12) shows that the input inductor of the SC ac–ac converter can be designed smaller [13], because it charges and discharges twice in one switching cycle of the converter; however, the SC ac–ac converters require CL1 and CL2 to limit their circulating currents. The magnetizing inductances of CL1 and CL2 determine the circulating current ripples only and have no effect on the current ripple of the filter inductor (input inductor for boost type converter). The maximum current ripple ($\Delta i_{x,max}$) of CL1 and CL2 in [13] is expressed as

$$\Delta i_{x,max} = \left(\frac{1}{L_s} + \frac{1-2D}{L_{sc}} \right) \frac{v_o}{4} DT_s, \quad x=1, 2, 3, 4 \quad (13)$$

Where L_s is self-inductance of CL1 and CL2 shown in Fig.1(c). For CL1 and CL2 to maintain the same inductor current ripples as in the proposed or traditional ac–ac converters ($\Delta i_{x,max} = \Delta i_{in1} = \Delta i_{in,conv}$), using (12) and (13), we get

$$\frac{L_s}{L_{eq}(=L_{conv})} = \frac{1}{2(1-D)} \quad (14)$$

V. LOSS ANALYSIS OF THE PROPOSED CONVERTERS

A. Active Semiconductor Device (Switch)

In the following analysis, the minor current loops are ignored because the magnitude of current in these loops is very small and can be removed if current-sensing modules are used. The poor reverse recovery of the anti-parallel body diodes of power MOSFETs causes significant loss during conduction. This power loss increases significantly when the switching frequency is increased; therefore, IGBTs are

commonly employed as active switches in traditional ac–ac converters. The body diodes of active switches in the proposed ac–ac converters do not conduct, and therefore, the power MOSFETs in the proposed converters can be used with high switching frequency. In comparison with MOSFETs, the switching and conduction losses of IGBTs can be higher for the following reasons: first, the gate switching speed of IGBTs is not as fast as that of MOSFETs, and the overlap region of voltage and current, proportional to switching loss, is thus larger for IGBTs; second, IGBTs are associated with long tail current when turned off; and third, the MOSFETs have only resistive voltage drop, whereas IGBTs have fixed voltage drop [28].

For these reasons, the switching and conduction losses of the active switches in the proposed converters can be minimized by employing MOSFETs as active switches, with their low turn-on resistance and fast switching features. The switching loss and conduction loss of the active switches in the proposed converters can be smaller than that of the SC ac–ac converters, because the SC ac–ac converters are associated with extra circulating current component.

B. Passive Semiconductor Device (Diode)

The anti-parallel body diodes of the IGBTs have high reverse recovery losses when compared to fast recovery diodes. In the proposed converters, the body diodes of the MOSFETs do not conduct, and freewheeling diodes can be employed externally with very fast reverse recovery characteristics and low forward voltage drop. Therefore, diode loss in the proposed ac–ac converters can be reduced

significantly compared to traditional ac–ac converters. The diode loss of the proposed ac–ac converters is also smaller than that of the SC ac–ac converters because the SC ac–ac converters have extra circulating current component.

C. Inductor

To generalize the result, consider that the proposed converter has the limiting inductors and no input inductor and assume that the inductance of each limiting inductor is half of the inductance of the input inductor in the traditional ac–ac converter $L_{np} = L_{conv}/2$, and therefore, $L_{eq} = L_{conv}$. From this generalization, the winding losses of the proposed and traditional ac–ac converters are comparable, even though the proposed converters use four limiting inductors. This is because only two limiting inductors L_{n1} and L_{p2} conduct the major input current during positive half cycle of current, and the other two inductors L_{p1} and L_{n2} conduct the major input current during the negative half of the cycle, as shown in Fig.4.

Although the input inductor of the SC ac–ac converters can be designed smaller, the total winding losses of these converters are high because they use bulky coupled inductors to limit the circulating current. Consequently, the winding losses of inductors in the proposed ac–ac converters are comparable to those of traditional ac–ac converters and less than those of the SC ac–ac converters.

D. Capacitor

In the SC ac–ac converters, the circulating currents also passes through the capacitors $C1$ and $C2$; therefore, the overall capacitor loss of

the proposed converter is smaller than that of the SC ac–ac converters and comparable to those of the traditional ac–ac converters because like the traditional ac–ac converters, the proposed converter have no circulating currents, which exists for SC ac–ac converters.

This analysis shows that the total losses of the proposed converters can be less than those of traditional ac–ac converters and SC ac–ac converters; therefore, the proposed converters can obtain higher efficiency.

VI. SINGLE-PHASE INDUCTION MOTOR

The characteristics of single phase induction motors are identical to 3-phase induction motors except that single phase induction motor has no inherent starting torque and some special arrangements have to be made for making it self starting. It follows that during starting period the single phase induction motor must be converted to a type which is not a single phase induction motor in the sense in which the term is ordinarily used and it becomes a true single phase induction motor when it is running and after the speed and torque have been raised to a point beyond which the additional device may be dispensed with for these reasons, it is necessary to distinguish clearly between the starting period when it is a single phase induction motor. The starting device adds to the cost of the motor and also requires more space. For the same output a 1-phase motor about is 30% larger than a corresponding 3-phase motor.

The single phase induction motor in its simplest form is structurally the same as a poly-phase induction motor having a squirrel cage rotor, the only difference is that the single

phase induction motor has single winding on the stator which produces mmf stationary in space but alternating in space around the air gap and constant in time with respect to an observer moving with the mmf. The stator winding of the single phase motor is disposed in slots around the inner periphery of a laminated ring similar to the 3-phase motor.

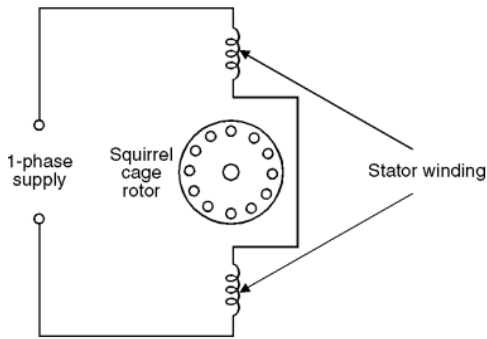

Fig.8 Single-phase induction motor

VII. MATLAB/SIMULINK RESULTS

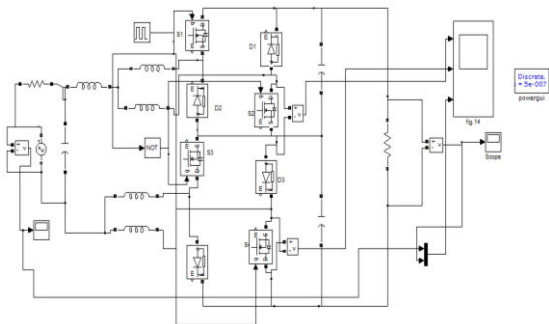

Fig.9 Simulink model of single-phase AC-AC converter

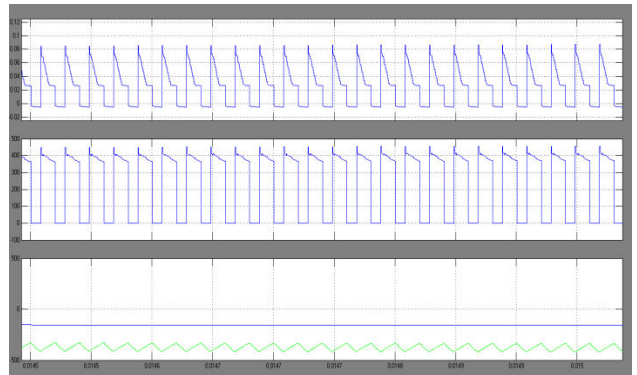
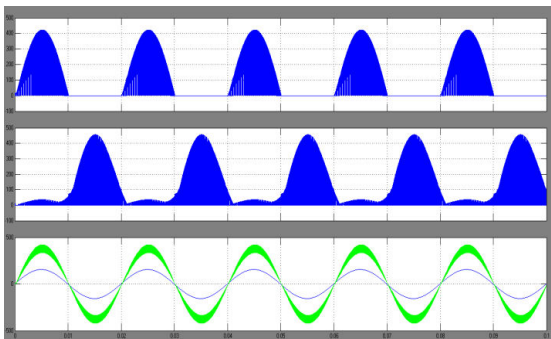

Fig.10 Experimental results with resistive load when $D=0.4$. (a) Waveforms of input voltage, output voltage, and drain to source voltages of switches S2 and S4. (b) Magnification of waveforms in (a).

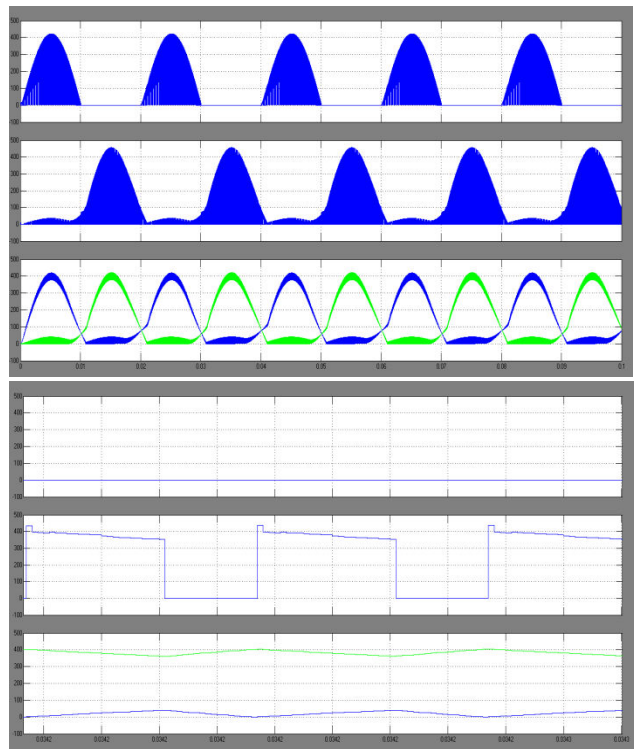

Fig.11 Experimental results with a resistive load when $D=0.4$. (a) Waveforms of voltages across capacitors C1 and C2 and drain to source voltages of S2 and S4. (b) Magnification of waveforms in (a).

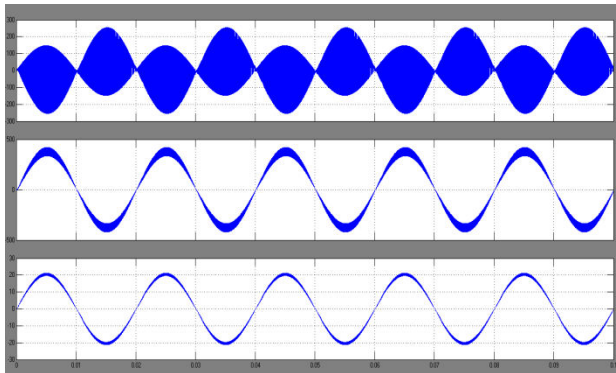

Fig.12. Experimental results with resistive load when $D=0.4$. Waveforms of input inductor voltage, output voltage and input inductor current.

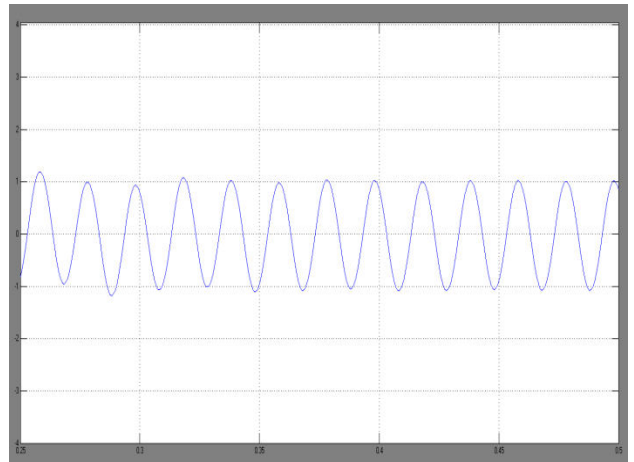

Fig.15 Stator current

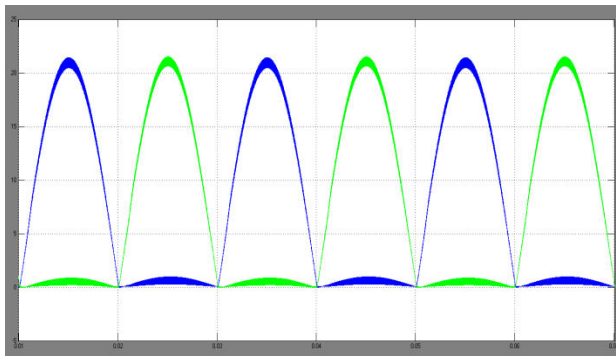

Fig.13. Experimental results with resistive load when $D=0.4$. Current Wave forms of limiting inductors.

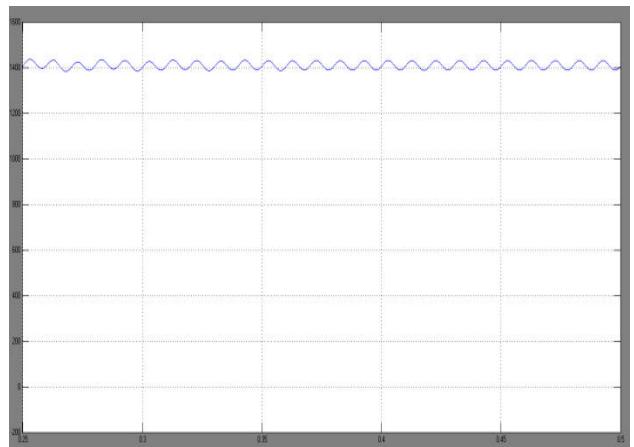

Fig.16 Speed of the Induction Motor

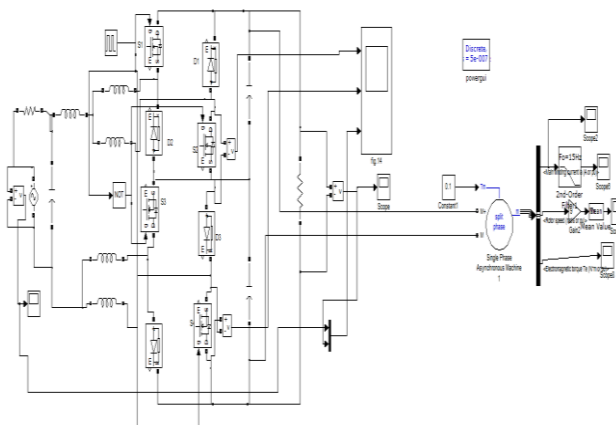

Fig.14 Simulink model of single-phase AC-AC converter with Induction Motor drive

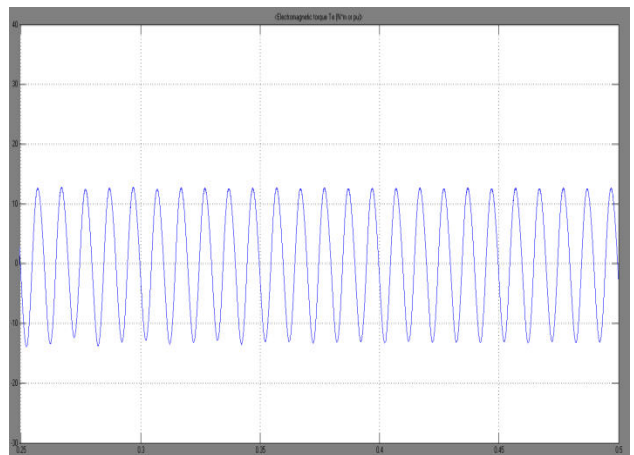

Fig.17 Torque characteristics of the induction motor

VIII. CONCLUSION

In this paper, several topologies for direct ac-ac converters permitting the use of commercial switch modules have been presented. The simulation has been carried out for the direct ac-ac converter with inverting and non inverting operations for R load. The new single phase PWM ac-ac converter has combined the operation of non-inverting buck and boost converters and inverting buck-boost converter in one topology. The simulation results clearly show that this new ac-ac converter can operate in both inverting and non inverting modes. The buck and boost modes of this converter are suitable for Induction motor drive applications with both step up and step down demand.

REFERENCES

- [1] M. K. Nguyen, Y. G. Jung, and Y. C. Lim, "Single-phase ac-ac converter based on quasi-Z-source topology," *IEEE Trans. Power Electron.*, vol. 25, no. 8, pp. 2200–2210, Aug. 2010.
- [2] F. Z. Peng, L. Chen, and F. Zhang, "Simple topologies of PWM ac-ac converters," *IEEE Power Electron. Lett.*, vol. 1, no. 1, pp. 10–13, Mar. 2003.
- [3] D. Vincenti, J. Hua, and P. Ziogas, "Design and implementation of a 25-kVA three-phase PWM AC line conditioner," *IEEE Trans. Power Electron.*, vol. 9, no. 4, pp. 384–389, Jul. 1994.
- [4] B. H. Kwon, G. Y. Jeong, S. H. Han, and D. H. Lee, "Novel line conditioner with voltage up/down capability," *IEEE Trans. Ind. Appl.*, vol. 49, no. 5, pp. 1110–1119, Oct. 2002.
- [5] S. Srinivasan and G. Venkataramanan, "Design of a versatile three-phase AC line conditioner," in *Proc. IEEE Ind. Appl. Soc.*, Oct. 1995, vol. 3, pp. 2492–2499.
- [6] Z. Fedyczak, R. Strzelecki, and G. Benysek, "Single-phase PWM AC/AC semiconductor transformer topologies and applications," in *Proc. 33rd Annu. IEEE Power Electron. Spec. Conf.*, Jun. 2002, pp. 1048–1053.
- [7] Y. D. Yoon and S. K. Sul, "Carrier-based modulation technique for matrix converter," *IEEE Trans. Power Electron.*, vol. 21, no. 6, pp. 1691–1703, Nov. 2006.
- [8] L. Wei and T. A. Lipo, "A novel matrix converter topology with simple commutation," in *Proc. IEEE IAS Annu. Meeting*, 2001, pp. 1749–1754.
- [9] X. P. Fang, Z. M. Qian, and F. Z. Peng, "Single-phase Z-source PWM ac-ac converters," *IEEE Power Electron. Lett.*, vol. 3, no. 4, pp. 121–124, Dec. 2005.
- [10] T. Yu, X. Shaojun, and Z. Chaohua, "Z-source AC-AC converters solving commutation problem," *IEEE Trans. Power Electron.*, vol. 22, no. 6, pp. 2146–2154, Nov. 2007.
- [11] H. Sarnago, O. Lucia, A. Mediano, and J. Burdio, "Efficient and cost effective ZCS direct AC-AC resonant converter for induction heating," *IEEE Trans. Ind. Electron.*, vol. 61, no. 5, pp. 2546–2555, May 2014.



[12] T. B. Lazzarin, R. L. Anderson, and I. Barbi, "A switched-capacitor three-phase AC–AC converter," *IEEE Trans. Ind. Electron.*, vol. 6, no. 2, pp. 735–745, Feb. 2015.

[13] H. Shin, H. Cha, H. Kim, and D. Yoo, "Novel single-phase PWM AC–AC converters solving commutation problem using switching cell structure and coupled inductor," *IEEE Trans. Power Electron.*, vol. 30, no. 4, pp. 2137–2147, Apr. 2015.

[14] H. Sarnago, O. Lucia, A. Mediano, and J. M. Burdoo, "Direct AC–AC resonant boost converter for efficient domestic induction heating applications," *IEEE Trans. Power Electron.*, vol. 29, no. 3, pp. 1128–1139, Mar. 2014.

[15] M.-K. Nguyen, Y.-C. Lim, and Y.-J. Kim, "A modified single-phase quasiZ-source AC–AC converter," *IEEE Trans. Power Electron.*, vol. 27, no. 1, pp. 201–210, Jan. 2012.