



## COPY RIGHT



**ELSEVIER**  
**SSRN**

**2023 IJIEMR.** Personal use of this material is permitted. Permission from IJIEMR must be obtained for all other uses, in any current or future media, including reprinting/republishing this material for advertising or promotional purposes, creating new collective works, for resale or redistribution to servers or lists, or reuse of any copyrighted component of this work in other works. No Reprint should be done to this paper, all copy right is authenticated to Paper Authors

IJIEMR Transactions, online available on 10<sup>th</sup> Apr 2023. Link

[:http://www.ijiemr.org/downloads.php?vol=Volume-12&issue=Issue 04](http://www.ijiemr.org/downloads.php?vol=Volume-12&issue=Issue 04)

**10.48047/IJIEMR/V12/ISSUE 04/76**

Title A THREE-PHASE INTERLEAVED FLYBACK SINGLE-STAGE AC-DC CONVERTER WITH A UNITY POWER FACTOR

Volume 12, ISSUE 04, Pages: 621-628

Paper Authors

P. Mahamood Khan, G. Vani Padma Priya, D. Kavya, A. Karthik, Ch. Ravi Kumar



USE THIS BARCODE TO ACCESS YOUR ONLINE PAPER

To Secure Your Paper As Per **UGC Guidelines** We Are Providing A Electronic Bar Code

## A Three-Phase Interleaved Flyback Single-Stage AC-DC Converter with a Unity Power Factor

**P. Mahamood Khan<sup>1</sup>**, Assist Prof, Department of EEE,  
Vasireddy Venkatadri Institute of Technology, Nambur, Guntur Dt., Andhra Pradesh.

**G. Vani Padma Priya<sup>2</sup>, D. Kavya<sup>3</sup>, A. Karthik<sup>4</sup>, Ch. Ravi Kumar<sup>5</sup>**  
<sup>2,3,4,5</sup> UG Students, Department of EEE,  
Vasireddy Venkatadri Institute of Technology, Nambur, Guntur Dt., Andhra Pradesh.  
pathanmehemudkhan@gmail.com, 19bq1a0246@vvit.net, 19bq1a0239@vvit.net, 19bq1a0227@vvit.net, 19bq1a0211@vvit.net

### Abstract

In this study, a three-phase, one-stage, interleaved flyback topology ac-dc converter is designed and built. The converter's primary use is in the telecommunications, where it provides dc power to telecom applications and performs large charging while providing the utility grid with zero periodic emission and a unity active power. The primary design goal is to create the smallest system at the lowest cost. The ideal number of overlapped cells and the system employs mathematical analysis and simulation to identify the relevant transitions among the cells with the focus on the creation of a flyback transformer with great coupling. For maximum performance, it's essential to design a transformer with the minimum possible leakage inductance and choose components that have the fewest parasitic effects. A complete protocol is used to find the design's function once the design has been verified using Simulink and the PLECS (piecewise linear electrical circuit simulation model) of the converter. In conclusion, experimental findings show that the converter operates effectively and fulfils the requirements for commercialization.

**Keywords:** Backward converter, a line output transformer, converter interleaved, single-stage converter

### I Introduction:

Important power-quality issues include harmonics extracted from utility lines as a result of distorted waveforms of current and the minimum power factor these currents cause. Using two-stage power conversion schemes is a typical solution for these issues in high-power

applications. An additional serial stage, is used in the two-stage schemes to generate controlled output with quick dynamic reaction and solitude after the power-factor correction stage, which eliminates harmonic currents, has completed. However, the converters in series make the system heavy, which raises the price

and the size of the final product. Because of this, extensive study has been done to create simpler single-stage systems that work just as well as their two-stage equivalents. The major manufacturers are still searching for ways to implement alternative systems that enhance the features of currently on the market products while also providing lower costs, smaller sizes, and simpler control specifications with rapid dynamic reactions. According to research, fly back based converter topologies have the greatest chance of meeting these requirements since they have the fewest components, the most separation, and the best control design. Moreover, according to studies to date, the flyback topology is more applicable for minimum use of power specifications, because of the flyback transformer's leakage inductance's low efficiency and the parasitic effects, which are more pronounced in maximum value-power applications. In order to increase the effectiveness of flyback-based systems, a lot of effort has been done. However, except from a few, not many ideas have truly demonstrated reality in the high-power range. We recommend a novel design in this paper that exemplifies the viability of one stage flyback-based PFC systems in high-power uses .

Fig. 1 depicts the suggested conversion system's circuit topology. The converter uses interleaved cells as its foundation, with flyback topologies in each cell that

operate in discontinuous current mode (DCM). In the design ,the converter's actual cell number is selected for development, despite the fact that Fig. 1 depicts two-cell interleaving. Operating in DCM mode has a number of benefits, including the removal of switching losses during switch-ON and losses along with the diodes' reverse direction recovery, the elimination of zero half-plane in the input loop, which enables strong and stable limit, and last but not least, the quick dynamic response. The continuous current waveforms with large peaks at the converter's input and output are the fundamental drawback of operating in DCM. In order to eliminate the high-frequency aspects of the current and minimise electromagnetic interference, a minimum -pass filter at the input and an output capacitive smoothing filter, as shown in Fig. 1, are required (EMI).

Moreover, each of these filters should have a high rms current capacity, notably the capacitor at the output. Moreover, DCM operation is called to result in lower efficiency because the current waveforms' elevated peak to average ratio. All of them are correct for more-power single unit applications, although using interleaving can significantly improve things. Because the power will be distributed evenly across the cells thanks to interleaving, it also helps to eliminate the discontinuity in the waveform of current

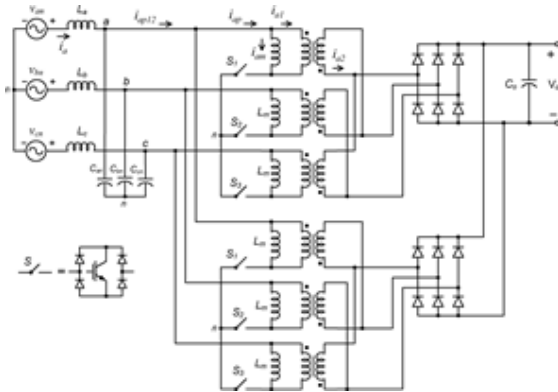

Fig 1 depicts the circuit diagram of the proposed two interleaved converter.

Despite yet, the leakage inductance issue is thought to be effectively solved by a constructed flyback transformer wound on a dispensed air-gapped ferrite core with a bigger window area and using sandwiched winding methods. The work that was presented in put the non-interleaved converter into practice and produced results that served as evidence of concept. Now, in this research, significant design advancements have been achieved in addition to interleaving to transform the notion from a topic into a marketable product. As mentioned, the major design requirements, which are mainly focusing the parasitic inductances in the circuit elements include the following points:

1. Instead of using bus bars, all of the power wires that transport electricity are shifted to the printed circuit board (PCB).
2. To minimize inductive parasitism, small-sized parallel elements with lower current ratings are used rather than larger single components.

3. Delta connections are used on the flyback transformers' secondary sides for two reasons: first, they prevent zero sequence currents from flowing to the output, and second, they allow for smaller turns ratios on the transformers. Less winding layers and fewer primary turns result from this.

### Operational Principles of Converter:

Flyback-based converters use magnetic components, specifically the magnetising inductance of the flyback transformers depicted in Figure 1, to perform an indirect energy conversion. The same gate pulse is used to concurrently operate the three controlled switches connected in cascaded with the transformer primary. The primary winding current and core flux start at zero and increase most linearly to their maximum values each time the switches are activated due to the DCM operation. The flyback transformer's magnetising inductance ( $L_m$ ) stores energy in this mode, and because the output diodes prevent current from flowing to the secondary side, the load is powered by the output Capacitor ( $C_o$ ). No energy is extracted from the source during the energy transfer to the output, which takes place when the switches are off. The flyback transformer secondary windings and the three-phase rectifiers transfer the energy held in the magnetising inductances of each phase to the output. The capacitor  $C_o$  smoothed out the ripple at the output voltage brought on by the rectified secondary currents. Using the



pulse width modulation (PWM) approach, the duty ratio of switches is adjusted during a predetermined switching period to regulate the average output voltage. The dc output voltage shows across the primary winding as a non positive voltage while the switch is still off, resetting the flux in the core.

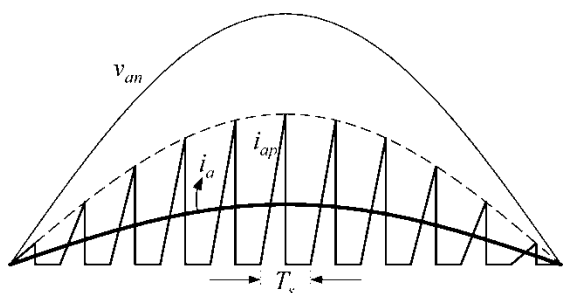

Fig 2 shows Conceptual waveforms of the input voltage ( $v_{an}$ ), the flyback transformer primary winding current ( $i_{ap}$ ), and its instantaneous average ( $i_a$ ).

### ANALYSIS OF CONVERTER:

During the output's off period, energy is transferred from the source to the interleaved converter's cells all receive the same input ac voltage. The power sharing of the cells is automatically accomplished because they are built with identical components and emit PWM pulses under the same control signal. To extract the required design equations, the analysis can be done using just one phase and over a half-cycle of the voltage, as illustrated in Fig. 2. Voltage  $v_{an}$  in Fig. 2 represents the Conceptual line-to-neutral input voltage, which is pure sinusoidal wave and equal to  $V_{bn}(t) = (V_{bn} \sin \omega t)$ . Current ( $i_{bp}$ ) is the instantaneous flyback transformer

primary winding current.

The running average of  $i_{ap}$  can be shown as  $i_a(t) = \hat{I}_a (\sin \omega t)$ .

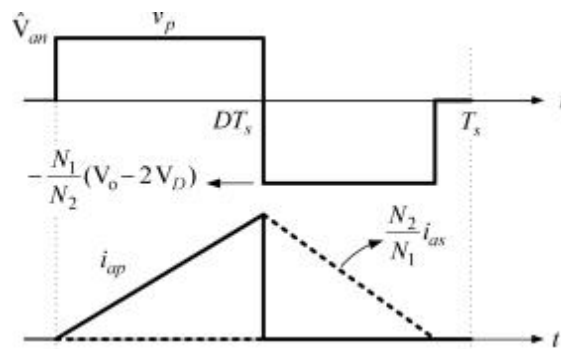

Fig. 3. Waveforms of the transformer primary voltage  $v_q$  the transformer primary current ( $i_{bq}$ ) secondary current  $i_{as}$  referred to primary side.

The current in the primary side mean value at  $v_{an}$ 's maximum value determines the value of the current pulled drawn from the line, which is  $I_a$ .

$$\hat{I}_a = \frac{1}{2} \hat{I}_{ap} D \quad (1)$$

$$\hat{I}_{ap} = \frac{\hat{V}_{an} D}{L_m f_s} \quad (2)$$

where  $I_{ap}$  is the maximum value of the current in primary side winding,  $V_{an}$  is the maximum input voltage,  $D$  is the duty ratio,  $L_m$  is the magnetizing inductance, and  $f_s$  is the switching frequency.

$$P_a = \frac{1}{2} \hat{V}_{an} \hat{I}_a \quad (3)$$

From eq (1-3), the duty ratio can be followed as,

$$D = 2/\hat{V}_{an} \sqrt{P_a L_m f_s}. \quad (4)$$

Eq 4 can be rewritten in ways of average output power as:

$$D = \frac{2}{\hat{V}_{an}} \sqrt{\left(\frac{P_o}{3\eta}\right) L_m f_s}. \quad (5)$$

the turns ratio of the transformer is obtained as

$$n = \frac{N_1}{N_2} = \frac{\hat{V}_{an} D}{(1-D)(V_o + 2V_D)} \quad (6)$$

where  $V_o$  is the average output voltage and  $V_D$  is the diode voltage. Then, using the following equations, the ideal number of turns in primary side  $N_1$  and the core area  $A_{core}$ , and finally, the air gapped length  $l_g$  are determined:

$$\lambda_{max} = \frac{\hat{V}_{an} D}{f_s} = 2 \sqrt{\frac{P_a L_m}{f_s}} \quad (7)$$

$$N_1 A_{core} = \frac{\lambda_{max}}{B_{sat}} \quad (8)$$

$$l_g = \frac{N_1^2 \mu_o A_{core}}{L_m} \quad (9)$$

Our main aim is to design a product that provides these qualities with low cost, complexity, and area. Our method to get an ideal interleaved design includes two main parts. First,

a non interleaved design at full capacity power and various overlapped designs with differential number of cells

TABLE 1: SUMMARY OF DESIGN PARAMETERS

Parameters		Non-interleaved	3-cell interleaved
Switching frequency	$f_s$	20 kHz	20 kHz
Duty ratio	$D$	30.62-77.30 %	30.62-77.30 %
Magnetizing inductance	$L_m$	50 $\mu$ H	<b>150 <math>\mu</math>H</b>
Flux linkage	$\lambda_{max}$	5.74 mWb	5.74 mWb
Primary number of turns	$N_1$	18	18
Secondary number of turns	$N_2$	2	2
Core area	$A_{core}$	840 $mm^2$	840 $mm^2$
Maximum magnetic flux density	$B_{max}$	0.38 T	0.38 T
Air gap length	$l_g$	6.84 mm	<b>2.28 mm</b>
Maximum switch voltage	$V_{sw}$	850 V	850 V

TABLE 2: SIMULATED RESULTS

Compared parameters	Non-interleaved	3-cell interleaved	
The output capacitor RMS ripple current	386 A	171 A	56 % reduction
The output capacitance ( $C_o$ )	14700 $\mu$ F	2870 $\mu$ F	80 % reduction
The output voltage ripple ( $\Delta V_o$ )	0.48 V	0.48 V	no change
The peak value of rectified DC current	1650 A	550 A	67 % reduction
The peak value of input current	115 A	42 A	63 % reduction
RMS input current	28.84 A	16.67 A	42 % reduction
THD of input current	2.99%	0.09%	97 % reduction

TABLE 3: NAME OF THE ELEMENTS USED IN THE POWER STAGE

Part description	Description of the components	Manufacturer part number
IGBTs	1200 V 42 A Non-Punch Through SOT-227 package	APT75GT120JRDQ3
Diodes	1200 V 93 A Ultrafast soft recovery SOT-227 package	APT2x101D120J
Schottky diodes	150 V 100 A dual SOT-227 package	IXYS DSS 2x101-015A
Output capacitors	110 $\mu$ F 450 V DC Metallized Polypropylene Film	EPCOS B32778G4117K
Clamp capacitors	8 $\mu$ F 1300 V DC Metallized Polypropylene Film	EPCOS B32776G1805K

When compared to noninterleaved design, there are significant benefits for the low leakage transformer design. Although it is a disadvantage to add two more transformers of the same size to the system, this extra areas anticipated to be justified by the interleaved converter' total area. The key advantages of three-cell interleaving over noninterleaved design are listed in Table III

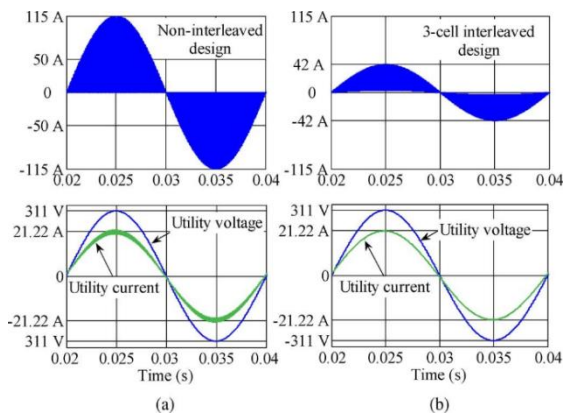
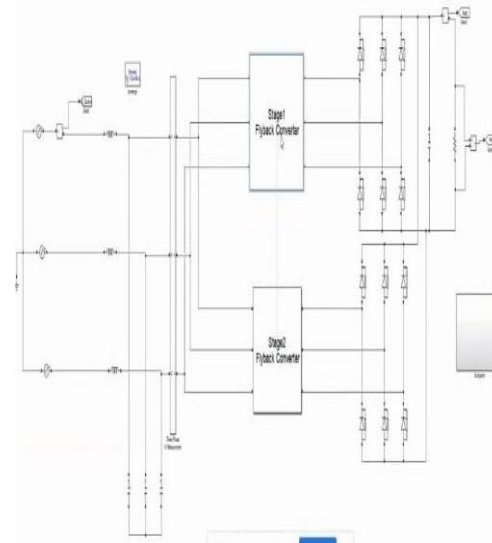

FIG.4 shows simulated waveforms of transformer primary current. (a) non interleaved case (b) three cell interleaved case.

The three-cell inter-linking significantly reduces the peaks of current, as can be seen in the upper trace of Fig. 4(b). Moreover, it increases ripple frequency by a factor of three and significantly lowers

wave form discontinuities.



Fig,6 simulink model.

### Experimental Results

Once we give the findings of the interleaving procedure, the performance of the converter will be assessed. Figure 9(a) displays the calculated voltage and the current from primary winding of a flyback transformer for one phase of a one cell, whereas Figure 9(b) displays the waveforms up close when the input voltage is at its maximum. The duty ratio will be less than half for the majority of input voltages, as stated in Section III, because the converter is intended to function in a very wide range of input voltages. For instance, the current is shown on the waveform in Fig. 9(b) when the duty ratio is 0.33.

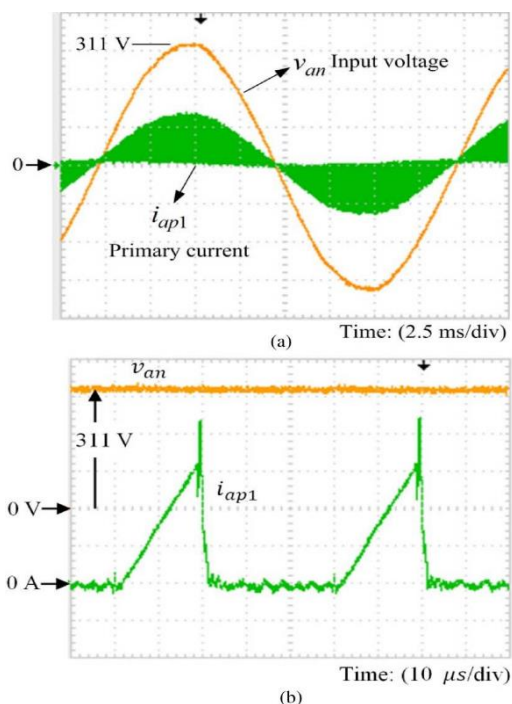

Fig. 9. (a) Computed input voltage  $v_{an}$  (100 V/division) and the primary current belonging to single phase of a unique cell  $i_{ap}$  (25 A/division, 2.5 ms/division). 9(b) shows near by view of same waveforms.

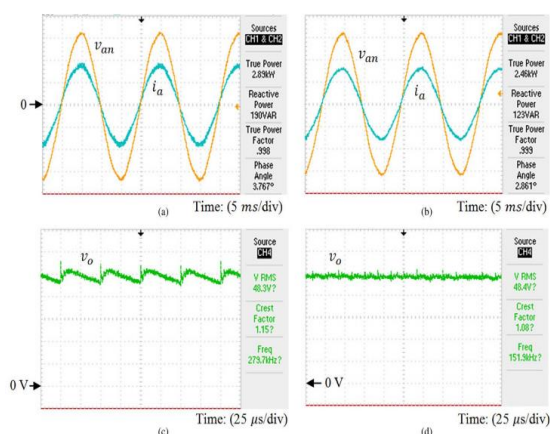

Fig 10: Converter output voltage  $v_o$  (10 V/division) and the ac side input (utility) current  $i_a$  (20 A/division) extracted by one phase of the converter.

## CONCLUSION:

The model and hypothetical validation of a 3 phase, one-stage operated in a DCM are discussed in this study. The primary design goal is to build a multistage, complicated converter structure solution that is commercially viable for telecom rectifier applications. The optimal cells to be overlapped was determined through mathematical analysis and simulation steps included in the study. Three cells interleaving is the best option given the requirements of affordable cost, small size, maximum performance, and best performance. Later, a 3 cell, interleaved prototype converter with a 3 kVA rating for each cell was created and put through testing. The test results show that the converter successfully attains a single-stage, unity power factor and continual output voltage regulation. This study also demonstrates the development of a high-power flyback transformer with extremely low leakage and the important role that interleaving plays in reducing the drawbacks of DCM operation. An overall converter efficiency of 87% as a result of these design changes is comparable to two stage designs.

During the design and implementation phases, the additional advantages of the flyback topology, such as minimal cost, almost no harmonic release to the utility lines, smallest size, solitude, and very simple specifications, are maintained.



## REFERENCES:

- [1] Prasad, S. U., Zegas, I. O., & Manas, U. (1981) A three-phase diode rectifier active power factor adjustment technology. *IEEE transactions on Power Electronics*, 6(1), 83-92.
- [2] R. W. Igaashi seth and I. Takaashi, "Unity power Factor using a single switching device," in *Proc. IEEE Ind. App. Soc. Annu. Meeting*, 1884, pp. 869–574.
- [3] H. V. Lagar, A. Fernandez, , P. Sebastiane, and M. B. Hernano, "a single stage power supply, the flyback active power corrector's limitations, in *Proc. IEEE Power Electron. Spec.Conf.*, 17–21 Jun. 2004, pp. 1443–1448.