



# International Journal for Innovative Engineering and Management Research

A Peer Reviewed Open Access International Journal

www.ijiemr.org

## COPY RIGHT



**2022 IJIEMR.** Personal use of this material is permitted. Permission from IJIEMR must be obtained for all other uses, in any current or future media, including reprinting/republishing this material for advertising or promotional purposes, creating new collective works, for resale or redistribution to servers or lists, or reuse of any copyrighted component of this work in other works. No Reprint should be done to this paper, all copy right is authenticated to Paper Authors

IJIEMR Transactions, online available on 16th Feb 2022. Link

[:http://www.ijiemr.org/downloads.php?vol=Volume-11&issue=ISSUE-02](http://www.ijiemr.org/downloads.php?vol=Volume-11&issue=ISSUE-02)

**DOI: 10.48047/IJIEMR/V11/I02/15**

Title **DESIGN AND ANALYSIS OF SPINDLE USED IN MILLING MACHINE**

Volume 11, Issue 02, Pages: 115-124

Paper Authors

**SHAIK SAIDULU, ANAGANI SATEESH KUMAR**



USE THIS BARCODE TO ACCESS YOUR ONLINE PAPER

To Secure Your Paper As Per **UGC Guidelines** We Are Providing A Electronic Bar Code

## DESIGN AND ANALYSIS OF SPINDLE USED IN MILLING MACHINE

SHAIK SAIDULU

M-tech student Scholar  
Department of Mechanical Engineering,  
Velaga Nageswara Rao College of  
Engineering,  
Ponnuru;  
Guntur (Dt); A.P, India.

ANAGANI SATEESH KUMAR M-Tech

Assistant Professor  
Department of Mechanical Engineering,  
Velaga Nageswara Rao College Of  
Engineering,  
Ponnuru;  
Guntur (Dt); A.P

**Abstract:** In today's prosperous industrial development, with the multifarious design of products and reduction of production cycle, high speed machining technology has been widely adopted by manufacturers. With the development of the science and technology, the high frequency spindles has been taken place of the normal mechanical spindles more and more, and also be used of the numerical control machine with great effects.

In this thesis, high speed motorized spindle is designed and analyzed under the given load conditions. The spindle used in this thesis is that used in a milling machine. The 3D modeling of spindle is designed in Pro/Engineer. The material used for spindles is Steel. In this thesis, different materials are analyzed for spindle. Aluminum alloy 6061 and 7075 are replaced with steel. By replacing the steel with aluminum alloys, the weight of the spindle decreases. Structural and Dynamic analyses is done using Ansys software. Modal analysis also is done to determine the frequencies.

### (I) INTRODUCTION

#### INTRODUCTION TO MILLING

Milling is the machining technique of the usage of rotary cutters to remove material from a workpiece advancing (or feeding) in a path at an perspective with the axis of the tool. It covers a big range of various operations and machines, on scales from small character additives to large, heavy-responsibility gang milling operations. It is one of the most normally used approaches in enterprise and machine shops today for machining factors to particular sizes and shapes.

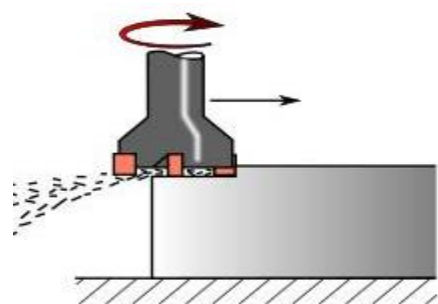

Fig 1 Face milling process

#### INTRODUCTION TO SPINDLE

In device equipment, a spindle is a rotating axis of the tool, which often has a shaft at its coronary heart. The shaft itself is referred to as a spindle, however additionally, in keep-floor exercise, the word often is used metonymically to seek advice from the entire rotary unit,

along with now not only the shaft itself, but its bearings and something connected to it (chuck, and so forth.).

A machine device may also additionally have numerous spindles, along side the headstock and tailstock spindles on a bench lathe. The main spindle is normally the biggest one. References to "the spindle" without similarly qualification advocate the primary spindle. Some machine gear specializing in immoderate-extent mass production have a hard and fast of 4, 6, or maybe more most important spindles. These are known as multispindle machines. For example, gang drills and masses of screw machines are multispindle machines. Although a bench lathe has more than one spindle (counting the tailstock), it isn't always called a multispindle machine; it has one critical spindle.

#### HIGH SPEED SPINDLES

A high speed spindle for you to be applied in a steel cutting system tool want to be designed to provide the desired overall performance capabilities. The foremost common overall performance capabilities encompass:

- Desired Spindle Power, Peak and Continuous
- Maximum Spindle Load, Axial and Radial
- Maximum Spindle
- Speed Allowed
- Tooling Style, Size and Capacity for ATC
- Belt Driven or Integral Motor-Spindle Design

## HIGH SEED SPINDLE DESIGN: MAJOR COMPONENT LIST

The number one additives required for a excessive tempo milling spindle layout embody:

- Spindle Style; Belt Driven or Integral Motor-Spindle
- Spindle Bearings; Type, Quantity, Mounting, and Lubrication Method
- Spindle Motor, Belt-Type, Motor-Spindle, Capacity, Size
- Spindle Shaft; Including Tool Retention Drawbar and Tooling System Used
- Spindle Housing; Size, Mounting Style, Capacity

## (II) LITERATURE SURVEY

In this paper through Deping Liu, Hang Zhang, Zheng Tao and YufengSu[1], gives a technique to investigate the characteristics of a excessive-pace motorized spindle system. This paper taking the high-speed milling motorized spindle of CX8075 produced via Anyang Xinsheng Machine Tool Co. Ltd. For instance, a finite detail model of the excessive-velocity motorized spindle is derived and offered. The outcomes display that the most rotating velocity of the motorized spindle is some distance smaller than the herbal resonance location pace, and the static stiffness of the spindle can meet the necessities of design. The static and dynamic traits of the motorized spindle accord with the requirements of high-pace machining. The thermal deformation of spindle is  $6.56\mu\text{m}$ , it's miles too small to affect the precision of the spindle. The outcomes illustrate the rationality of the spindle structural layout. In the paper through Lan Jin, Zhaoyang Yan, Liming Xie, Weidong Gou, Linhu Tang[2], a method is described on this paper for measuring the spindle rotation mistakes and a technique for separating the eccentric errors as a result of setup errors of the grasp cylinder. The machine consists of non-contact capacitance sensors used to measure the radial displacement of the rotating grasp cylinder and an LMS Test.Lab used to collect the measurement records. LMS Test.Lab gives a entire engineering answer for rotating equipment. Based on our experimental research, it indicates that this gadget can be used to measuring the spindle rotary errors at extraordinary speeds. It is likewise established the feasibility of the error separation methods developed on this paper. In the paper by R. Radulescu, S. G. Kapoor and R. E. DeVor[3], a mechanistic dynamic model is used to simulate a face milling technique at some point of consistent and variable speed machining. The version can be used to expect the premier speed trajectory which could offer a low stage of vibration and consequently a big productiveness charge and a small floor blunders.

## (III) INTRODUCTION TO CAD

### (A) Computer-aided layout

CAD Additionally known as laptop-aided layout and drafting (CADD), is using laptop technology for the technique of design and design-documentation. Computer Aided Drafting describes the system of drafting with a computer. CADD software, or environments, offer the user with input-gear for the cause of streamlining layout tactics; drafting, documentation, and manufacturing approaches. CADD output is frequently within the shape of digital files for print or machining operations. The improvement of CADD-based software is in direct correlation with the techniques it seeks to save money; enterprise-based totally software (production, manufacturing, and so on.) generally uses vector-based totally (linear) environments while photograph-primarily based software program utilizes raster-primarily based (pixelated) environments.

### Pro/ENGINEER

Wildfire is the standard in 3D product layout, providing enterprise-main productiveness tools that sell great practices in design while ensuring compliance along with your industry and company requirements. Integrated Pro/ENGINEER CAD/CAM/CAE solutions allow you to layout quicker than ever, even as maximizing innovation and high-quality to in the long run create extremely good merchandise.

Fig 4.1 spindle

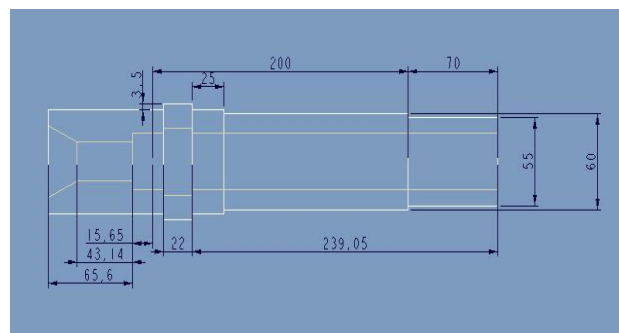
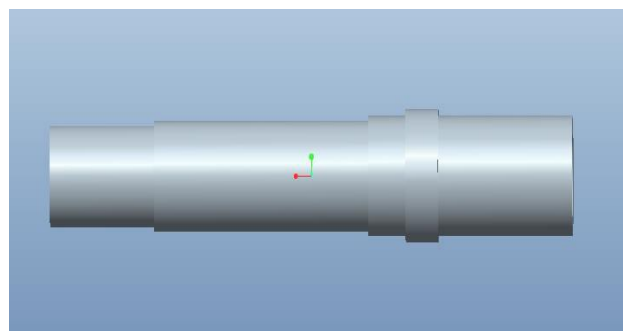

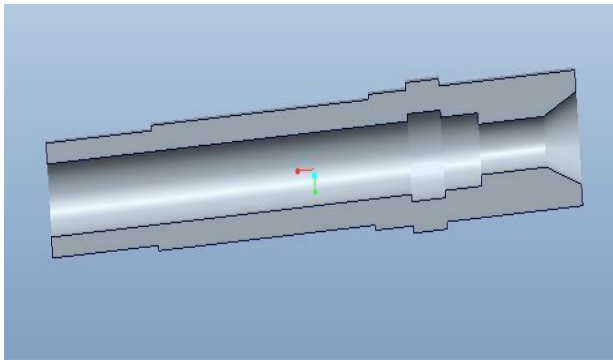

## STRESS

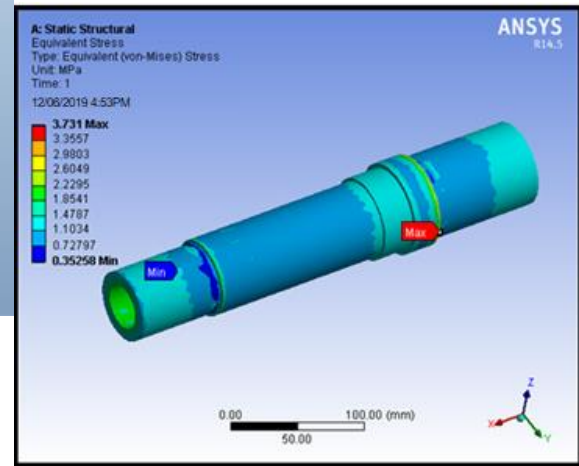

Fig 4.2 Cut section

### (IV) STATIC ANALYSIS OF HIGH SPEED MOTORIZED SPINDLE

#### Material properties

Material	Density (kg/mm <sup>3</sup> )	Young's modulus (MPa)	Poisson's ratio
Aluminum alloy 6061	0.0000027	68900	0.33
Aluminum 7075	0.0000028	71700	0.33
steel	0.00000785	205000	0.3
Carbon fiber	0.00000160	70000	0.3

## STRAIN

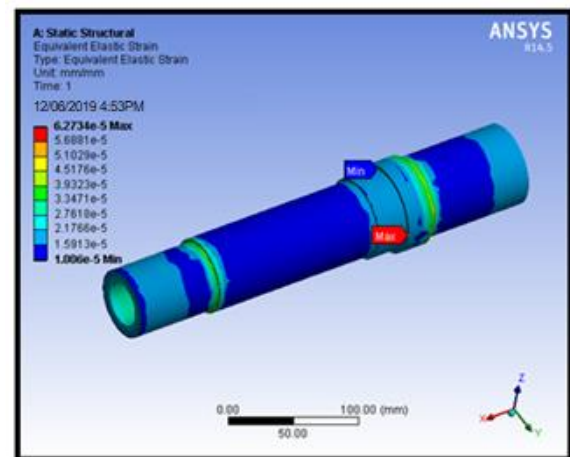

CASE: 1 SPINDLE SPEED 10000rpm

MATERIAL- ALUMINUM ALLOY 7075

DEFORMATION

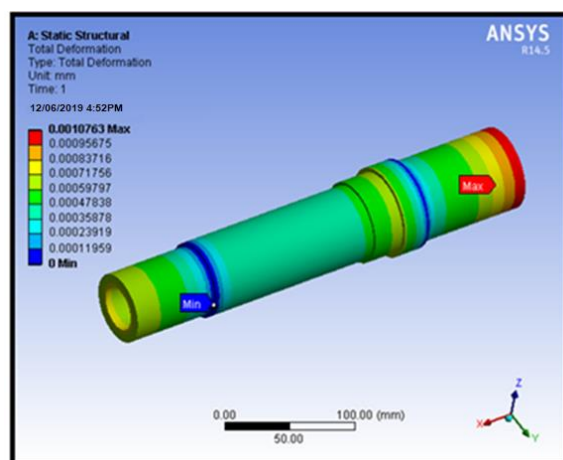

MATERIAL- ALUMINUM ALLOY 6061

DEFORMATION

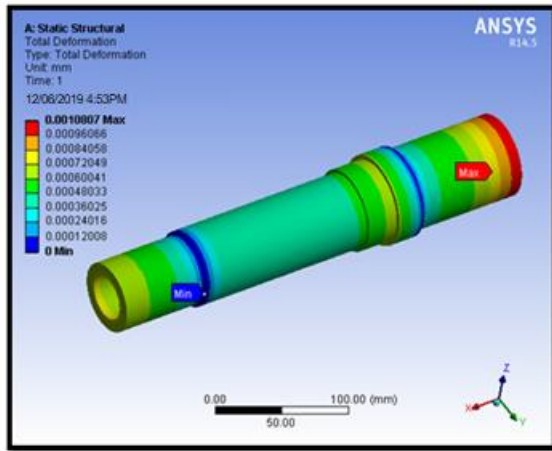

**STRESS**

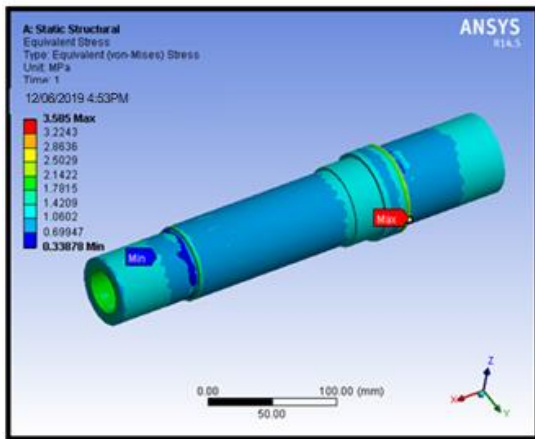

**STRAIN**

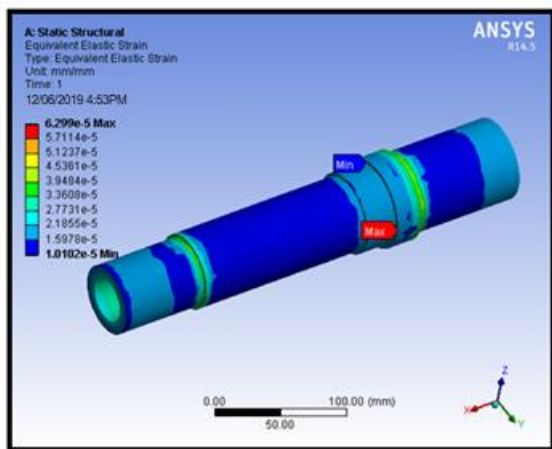

**MATERIAL- STEEL**

**DEFORMATION**

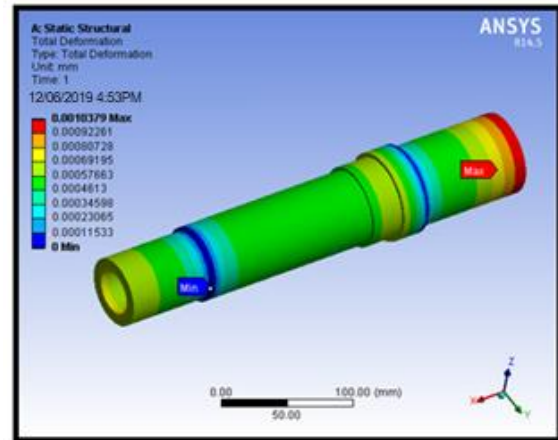

**STRESS**

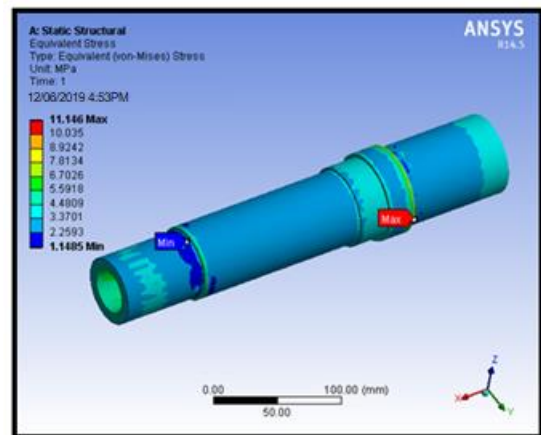

**STRAIN**

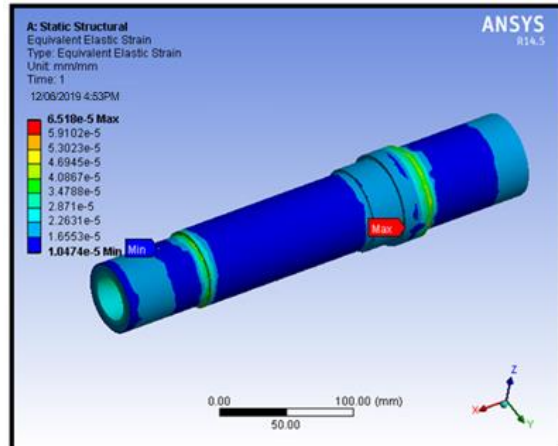

## MATERIAL- COMPOSITE FIBER DEFORMATION

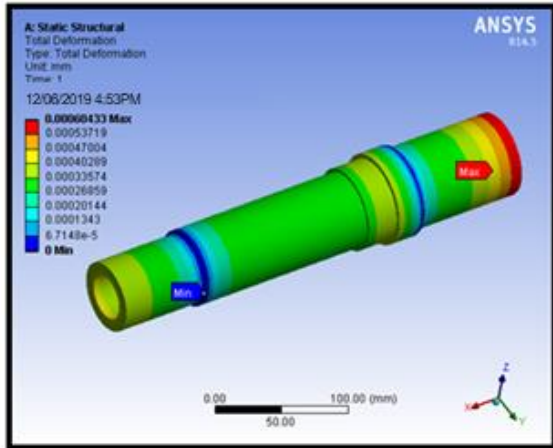

## CASE: 2 SPINDLE SPEED 13000RPM MATERIAL- ALUMINUM ALLOY 7075 DEFORMATION

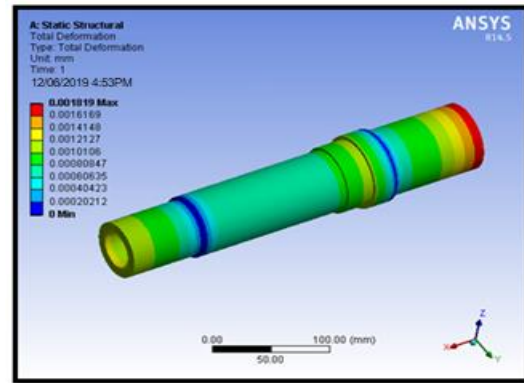

## STRESS

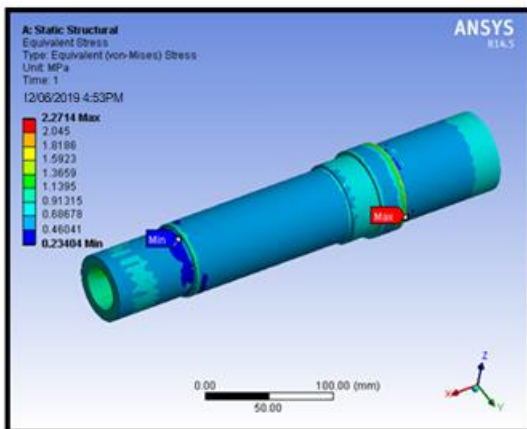

## STRESS

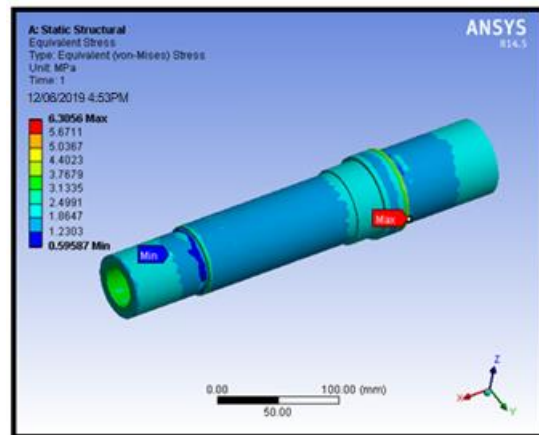

## STRAIN

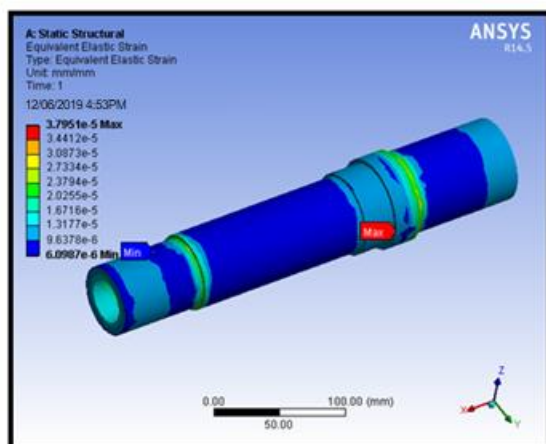

## STRAIN

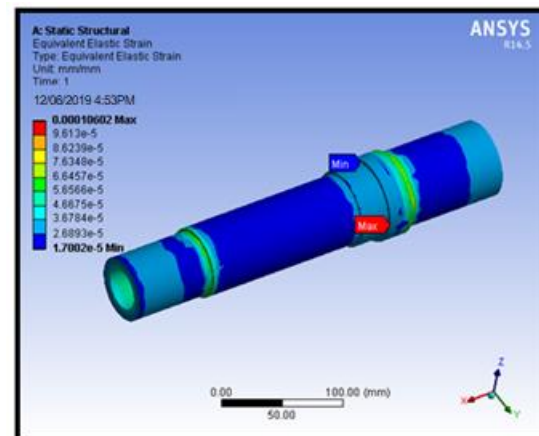

## MATERIAL- COMPOSITE FIBER DEFORMATION

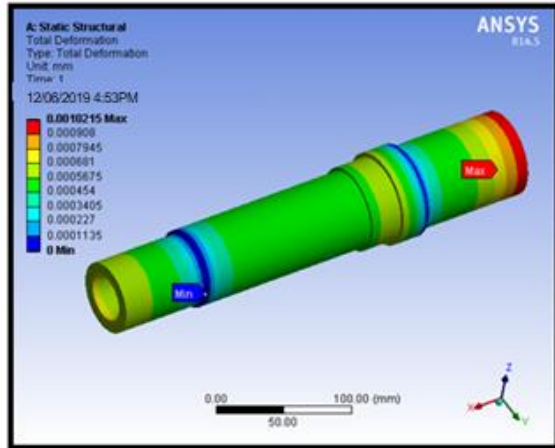

## CASE: 3 SPINDLE SPEED 16000RPM

## MATERIAL- ALUMINUM ALLOY 7075 DEFORMATION

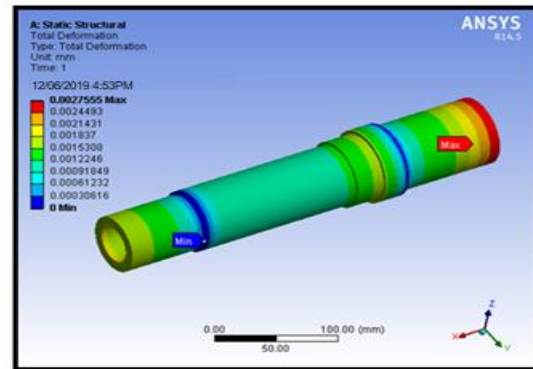

## STRESS

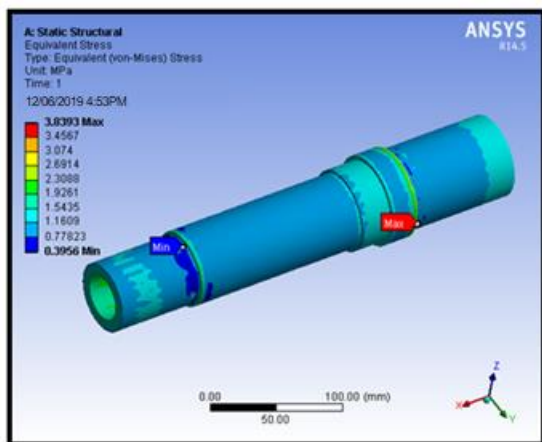

## STRESS

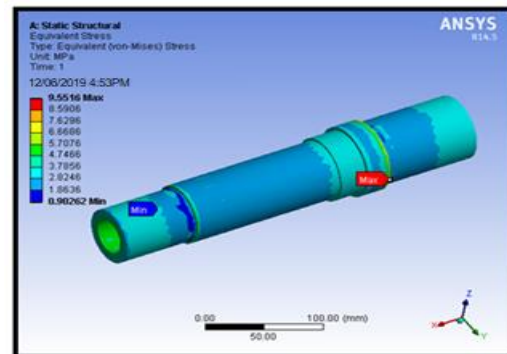

## STRAIN

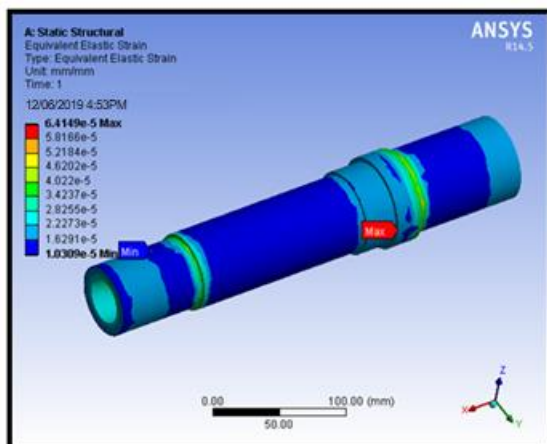

## STRAIN

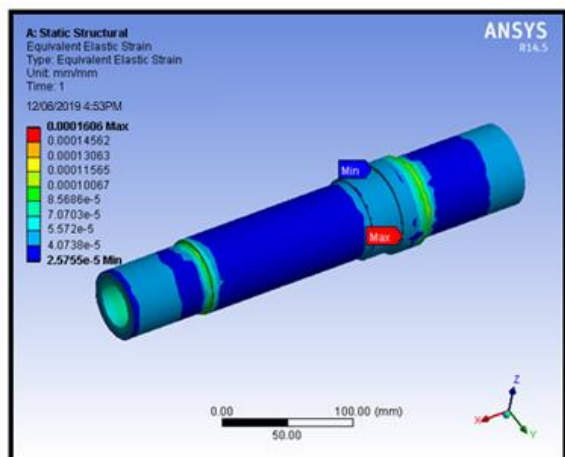

## MATERIAL- ALUMINUM ALLOY 6061 DEFORMATION

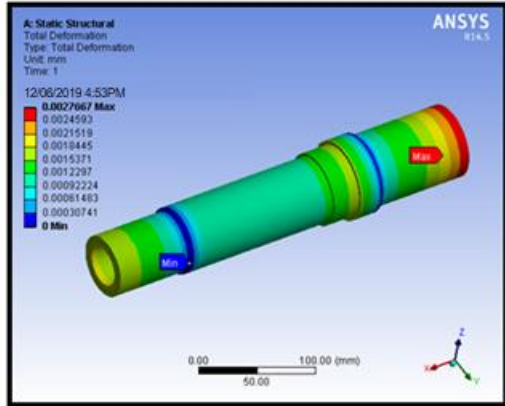

## MATERIAL- STEEL DEFORMATION

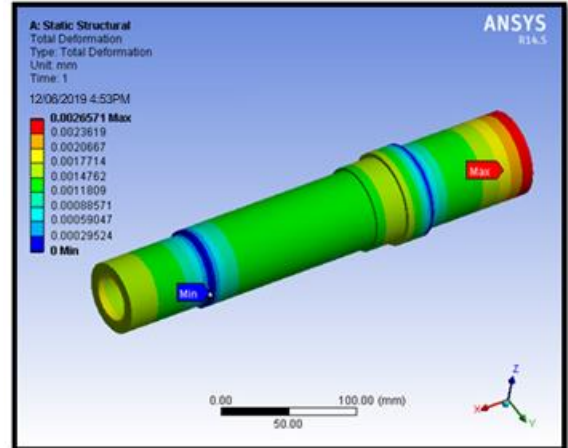

## STRESS

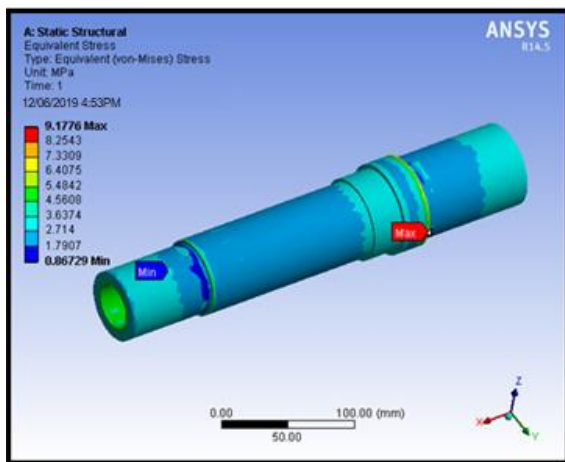

## STRESS

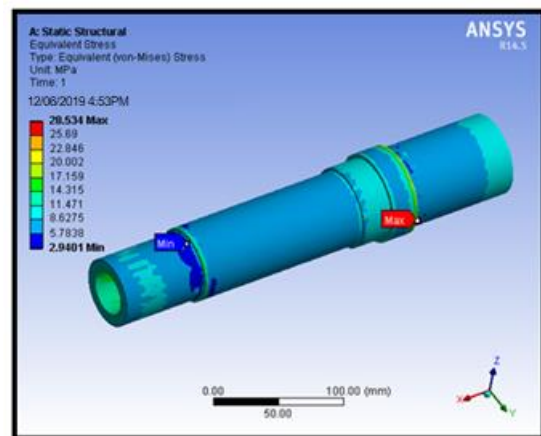

## STRAIN

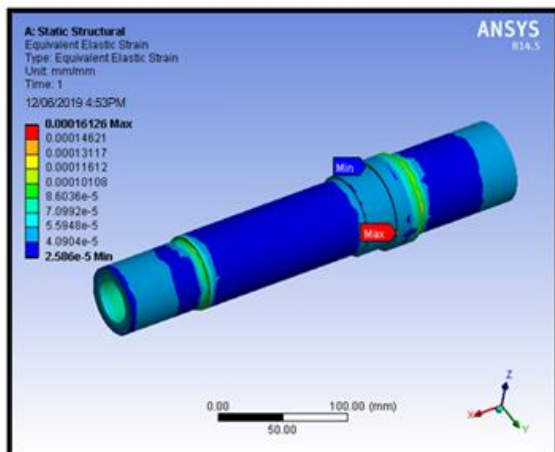

## STRAIN

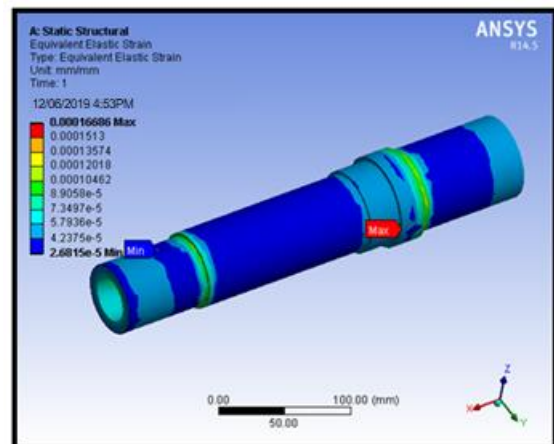



## MATERIAL- COMPOSITE FIBER

### DEFORMATION

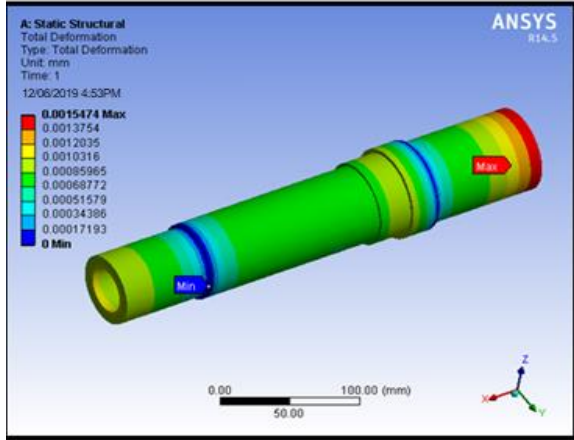

### STRESS

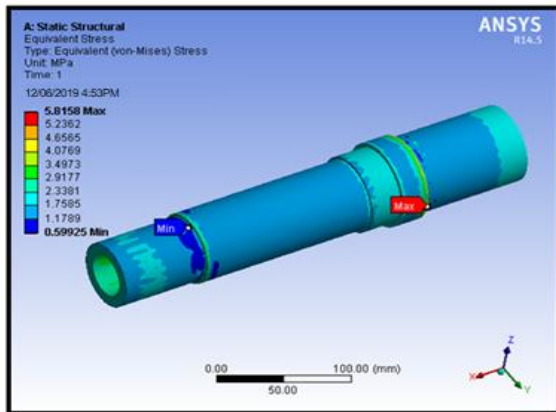

### STRAIN

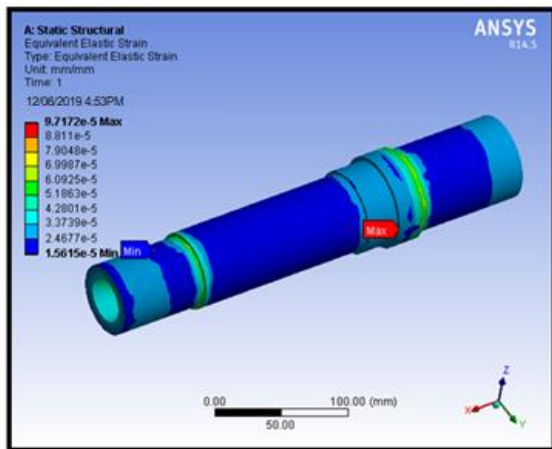

## MODAL ANALYSIS OF HIGH SPEED

### MOTORIZED SPINDLE

## MATERIAL- ALUMINUM ALLOY 6061

### DEFORMATION 1

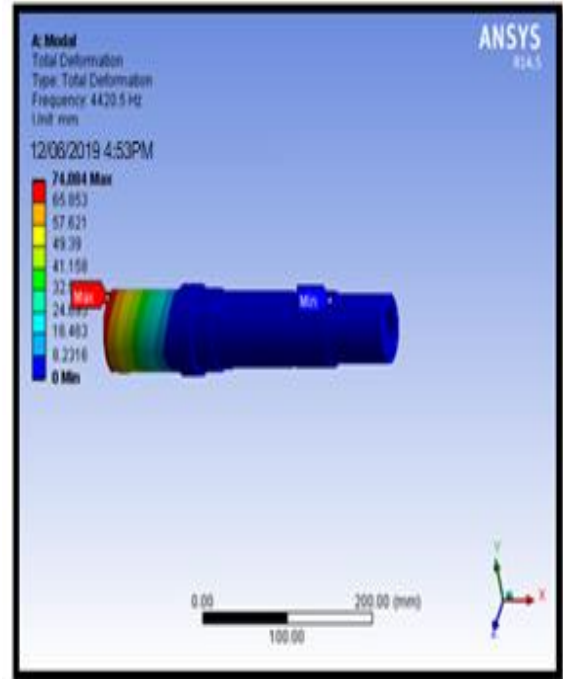

### DEFORMATION 2

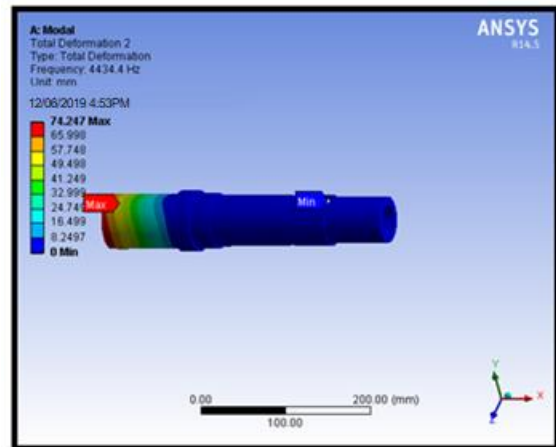

### DEFORMATION 3

## MATERIAL- ALUMINUM ALLOY 7075

### Static analysis results

Speed (rpm)	material	Deformation(mm)	Stress(MPa)	strain
10000	Aluminum alloy 7075	0.0010763	3.731	6.2734e-5
	Aluminum alloy 6061	0.0010807	3.585	6.299e-5
	steel	0.0010379	11.146	6.518e-5
	Carbon fiber	0.00060433	2.2714	3.7951e-5
13000	Aluminum alloy 7075	0.001819	6.3056	0.00010602
	Aluminum alloy 6061	0.0018265	6.0587	0.00010645
	steel	0.0017541	18.837	0.00011016
	Carbon fiber	0.0010215	3.8393	6.4149e-5
16000	Aluminum alloy 7075	0.002755	9.5516	0.00016006
	Aluminum alloy 6061	0.0027667	9.1776	0.00016126
	steel	0.0026571	28.534	0.00016686
	Carbon fiber	0.001547	5.8158	9.712e-5

### Modal analysis results

Material	Modes	Deformation (mm)	Frequency (Hz)
Aluminum 7075	1	72.749	4437.4
	2	72.91	4451.4
	3	47.563	5552.4
Aluminum 6061	1	74.084	4420.5
	2	74.247	4434.4
	3	48.436	5531.3
Steel	1	43.481	4400.8
	2	43.571	4413.4
	3	28.36	5539
Carbon fiber	1	96.31	5766.9
	2	96.509	5783.4
	3	62.818	7258.8

### Static analysis graphs

#### Deformation plot

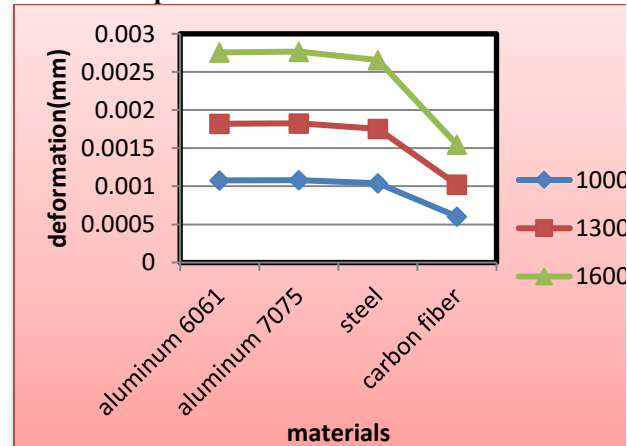

### Stress plot

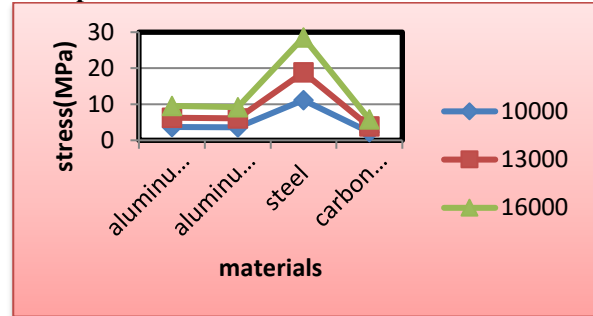

### Strain plot

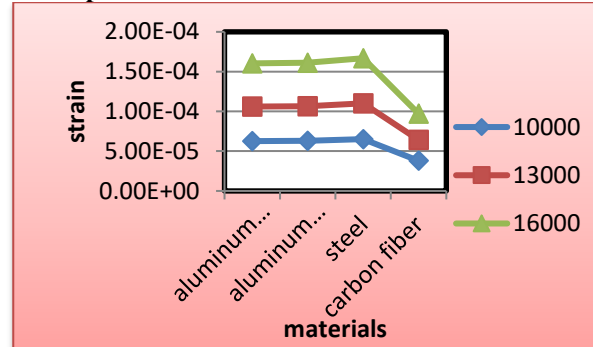

### Modal analysis graphs

#### Deformation plot

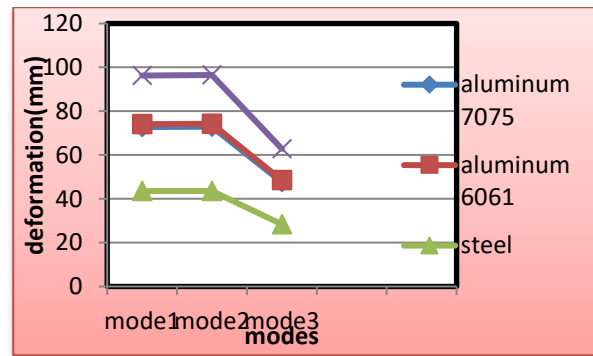

### Frequency plot

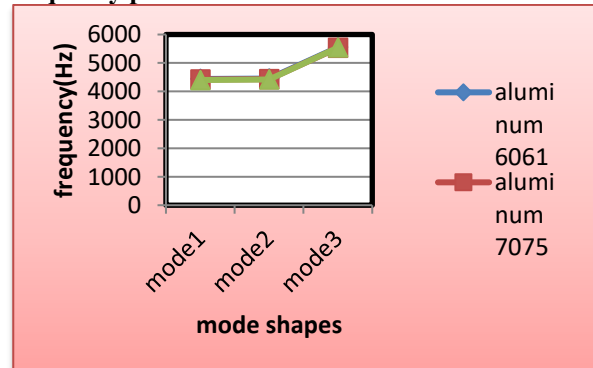

## **(V) CONCLUSION**

The geometric satisfactory of excessive-precision components is rather depending on the dynamic overall performance of the entire machining gadget, which is determined through the interrelated dynamics of device tool mechanical shape and reducing process. This performance is of outstanding significance in advanced, high-precision manufacturing strategies. The today's in device predominant spindle devices is awareness on motorized spindle units for excessive-speed and excessive performance slicing.

In this thesis, exclusive substances are analyzed for spindle. Aluminum alloy 6061 and 7075 are replaced with metal. By changing the metal with aluminum alloys, the weight of the spindle decreases. Structural and Dynamic analyses is performed the use of Ansys software program. Modal analysis is also performed to determine the frequencies.

By gazing the static and dynamic evaluation, the pressure boom by way of growing spindle velocity and stresses reducing for carbon fiber than aluminum 7075, aluminum 6061 and metallic.

By gazing the modal evaluation, the pressure growth by means of growing spindle velocity and stresses lowering for aluminum 7075 then aluminum 6061 and steel.

By gazing the modal evaluation, the deformation increases and frequency increasing for carbon fiber than aluminum 7075, aluminum 6061 and metallic.

So we finish the proper fabric for high speed motorized spindle is carbon fiber.

## **REFERENCES**

1.Design and analysis of high velocity motorized spindle. SyathAbuthakeer.S 1 , Mohanram P.V 1 , Mohan Kumar G 3 1- Department of Mechanical Engineering, PSG College of Technology, Coimbatore 3- Park college of Engineering and Technology, Coimbatore

2.Finite Element Analysis of High-Speed Motorized Spindle Based on ANSYS  
Deping Liu\* Hang Zhang, Zheng Tao and YufengSu

3.Dynamic and thermal analysis of high pace motorized spindle.

4.Dynamic traits analysis of high Speed motorized spindle  
1.2. Department of mechanical engineering, psg college of technology, coimbatore – 641 004, india three park university of engineering and technology, coimbatore, india