



# International Journal for Innovative Engineering and Management Research

A Peer Reviewed Open Access International Journal

www.ijiemr.org

## COPY RIGHT

**2017 IJIEMR.** Personal use of this material is permitted. Permission from IJIEMR must be obtained for all other uses, in any current or future media, including reprinting/republishing this material for advertising or promotional purposes, creating new collective works, for resale or redistribution to servers or lists, or reuse of any copyrighted component of this work in other works. No Reprint should be done to this paper, all copy right is authenticated to Paper Authors

IJIEMR Transactions, online available on 17<sup>th</sup> July 2017. Link :

<http://www.ijiemr.org/downloads.php?vol=Volume-6&issue=ISSUE-5>

Title: Modelling And Structural Thermal Analysis of A Low- Pressure Steam Turbine.

Volume 06, Issue 05, Page No: 1894 – 1904.

Paper Authors

**\* N. PRASHANTH, A. RADHA KRISHNA.**

\* DVR College of Engineering and Technology.



USE THIS BARCODE TO ACCESS YOUR ONLINE PAPER

To Secure Your Paper As Per **UGC Guidelines** We Are Providing A Electronic Bar Code

## MODELLING AND STRUCTURAL THERMAL ANALYSIS OF A LOW-PRESSURE STEAM TURBINE

**\*N. PRASHANTH,\*\* A. RADHA KRISHNA**

\*PG Scholar, Dept of thermal engineering, DVR College of Engineering and Technology, Hyderabad.

\*\*HOD, Dept of mechanical, DVR College of Engineering and Technology, Hyderabad.

### ABSTRACT:

A steam turbine is a device that extracts thermal energy from pressurized steam and uses it to do mechanical work on a rotating output shaft. The LP turbine is a pressure compounded, either single or dual axial flow, condensing reaction turbine. which receives the impulse directly from the steam jet and converts this force into the driving force. Statistics has shown that LP blades are usually more predisposed to failure compared to blades in HP or IP turbines. To efficiently extract work out of this lower pressure steam, reaction balding is used on the LP turbine. In this project work analyses the effects of thermal and structural load on a low steam turbine blade under the operating conditions. Stresses due to thermal of low Pressure Steam Turbine blade of power stations analyzed in working conditions. In first stage a three dimensional model of turbine blade was prepared in mechanical catia software. In this model using material is low steel alloys. CRE 2.0. This model will import in ANSYS-14.5 for Finite Element Analysis. Maximum stress and stress distribution is compute using Finite Element Analysis (FEA) at the corresponding section. This model will import in ANSYS-14.5 for thermal, structural Analysis. Maximum stress and stress distribution, and thermal stresses and failures is compute using Analysis at the corresponding section.

**Key words:** Low pressure Blade, Steam Turbine, Stress Distribution, and thermal Analysis, low steel alloys, ANSYS software.

### INTRODUCTION

A steam turbine is a device that extracts thermal energy from pressurized steam and uses it to do mechanical work on a rotating output shaft. Its modern manifestation was invented by Sir Charles Parsons in 1884. Because the turbine generates rotary motion, it is particularly suited to be used to drive an electrical generator – about 90% of all electricity generation in the United States (1996) is by use of steam turbines. The steam

turbine is a form of heat engine that derives much of its improvement in thermodynamic efficiency from the use of multiple stages in the expansion of the steam, which results in a closer approach to the ideal reversible expansion process.

#### 1.2 Turbine Classification:

In order to better understand turbine operation, five basic classifications are discussed. Type of compounding refers to the

use of blading which causes a series of pressure drops, a series of velocity drops, or a combination of the two. Division of steam flow indicates whether the steam flows in just one direction or if it flows in more than one direction. Type of steam flow describes the flow of steam in relation to the axis of the rotor. Exhausting condition is determined by whether the turbine exhausts into its own condenser or whether it exhausts into another piping system. Type of blading identifies the blading as either impulse blading or reaction blading.

## Types

1 High pressure turbine

2 Low pressure turbines

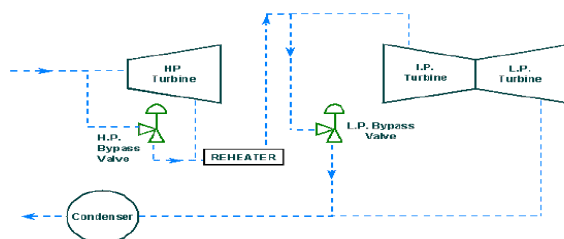

### 1.3 Low pressure turbine:

The LP turbine (see Figure ) is located next to the HP turbine. The LP turbine is a pressure compounded, either single or dual axial flow, condensing reaction turbine.

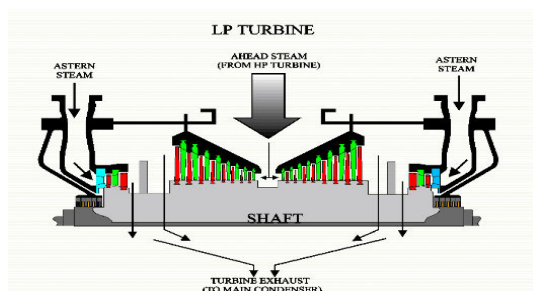

## CHAPTER – 2

### LITERATURE REVIEW:

1. Haselbach et al. presented a high-lift LP turbine design that was specific to the BR715 engine. The authors reported an increase in the measured performance differential between takeoff and cruise conditions that was attributed to increased endwall losses.
2. In a similar work, Gier and Ardey reported on the use of CFD-based transition modeling to design high-lift airfoils for a three-stage LP turbine rig. The authors applied aft loading to their high-lift designs and found that measured performance was lost more rapidly with decreasing Reynolds number compared to the conventional-lift design. This degradation in performance was attributed to boundary layer separation on the airfoil surfaces.
3. Prakash et al. reported on the effect of loading level and distribution (front, mid and aft) on LP turbine profile losses. The data demonstrated increased suction side separation and high losses as the loading level increases, the loading is moved aft or the Reynolds number decreases. Although secondary loss was not addressed by the authors, they did comment that front loaded blades typically have lower profile losses but higher secondary losses.

4. An important series of experiments that focussed on high work LPT stages was funded by NASA at General Electric in the 1970s and 80s. These include the multi-stage fan-drive turbine of Evans and Wolfmeyer and the 5-stage E 3 LPT of Cherry and Dengler that had average work coefficients of 3.0 and 2.66 per stage, respectively. Both studies achieved efficiencies near 90%, albeit with more conventional-lift airfoils with incompressible Zweifel coefficients of order 1.
5. Recently, Bons et al. tested a new cascade airfoil design, designated LIM, with  $Z_w = 1.34$ . This airfoil was designed with integrated flow control in anticipation that the high-lift design would require some form of separation control. However, the airfoil proved to perform well without the activation of the flow control.
6. The most highly loaded LP airfoil reported in the open literature appears to be that designed and investigated by Praisner et al. The authors tested airfoils with Zweifel coefficients of 1.62 and 1.82.

started from scratch or from 2D sketches. CATIA is able to read and produce STEP format files for reverse engineering and surface reuse

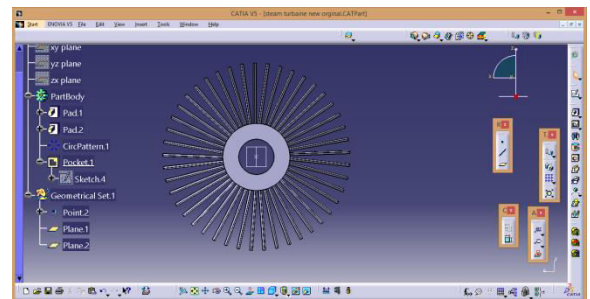
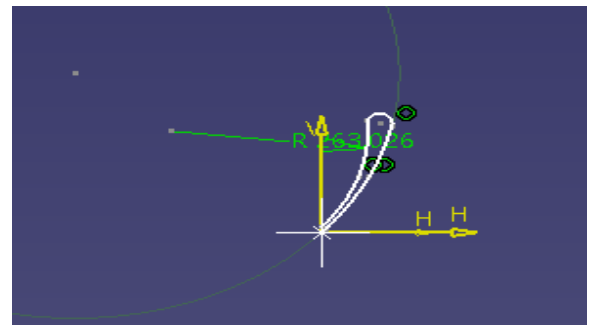
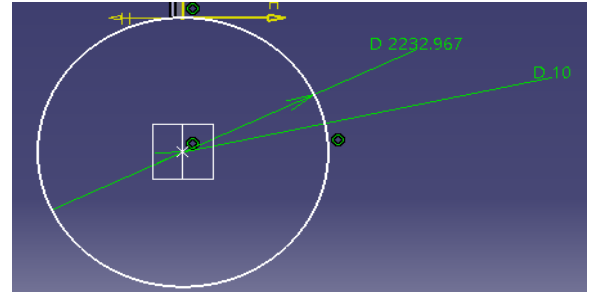

## Chapter3

### 3.1 DESIGN:

CATIA offers a solution to shape design, styling, surfacing workflow and visualization to create, modify, and validate complex innovative shapes from industrial design to Class-A surfacing with the ICEM surfacing technologies. CATIA supports multiple stages of product design whether

### 4 Ansys:

ANSYS is general-purpose finite element analysis software, which enables engineers to perform the following tasks:

1. Build computer models or transfer CAD model of structures, products, components or systems
2. Apply operating loads or other design performance conditions.

3. Study the physical responses such as stress levels, temperatures distributions or the impact of electromagnetic fields.
4. Optimize a design early in the development process to reduce production costs.
5. A typical ANSYS analysis has three distinct steps.
6. Pre Processor (Build the Model).

### Mash:

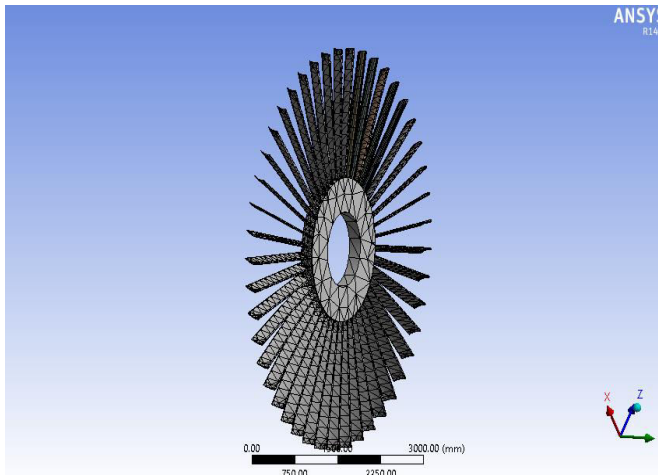

### study state Thermal:

The ANSYS/Mechanical, ANSYS/FLOTTRAN, and ANSYS/Thermal products support steady-state thermal analysis. A steady-state thermal analysis calculates the effects of steady thermal loads on a system or component. Engineer/analysts often perform a steady-state analysis before doing a transient thermal analysis, to help establish initial conditions. A transient analysis also can be the last step of a transient thermal analysis, performed after all transient effects have diminished.

You can use steady-state thermal analysis to determine temperatures, thermal gradients, heat flow rates, and heat fluxes in an object that are caused by thermal loads that do not vary over time. Such loads include the following:

- Convections
- Radiation
- Heat flow rates
- Heat fluxes (heat flow per unit area)
- Heat generation rates (heat flow per unit volume)
- Constant temperature boundaries.

A steady-state thermal analysis may be either linear, with constant material properties; or nonlinear, with material properties that depend on temperature. The thermal properties of most material do vary with temperature, so the analysis usually is nonlinear. Including radiation effects also makes the analysis nonlinear.

### Loads:

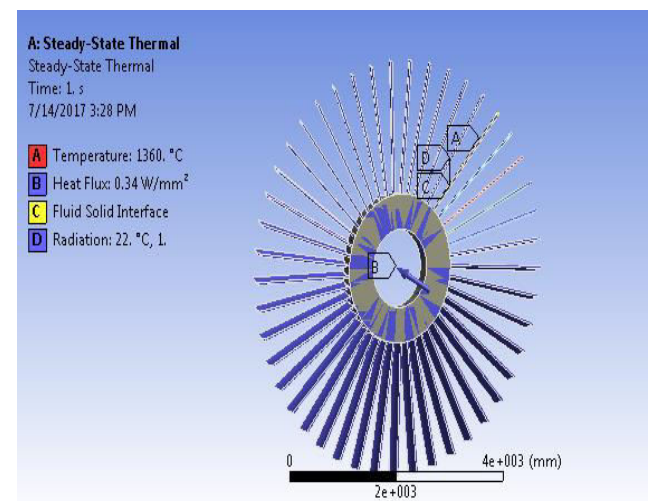

Type	Temperature	Heat Flux	Fluid Solid Interface	Radiation
Magnitude	1360. °C (ramped)	0.34 W/mm <sup>2</sup> (ramped)		
Suppressed	No			
Interface Number			1.	
Export Results			Yes	
Correlation				To Ambient
Emissivity				1. (step applied)
Ambient Temperature				22. °C (ramped)

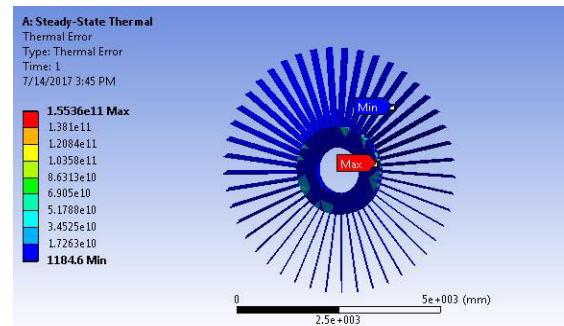
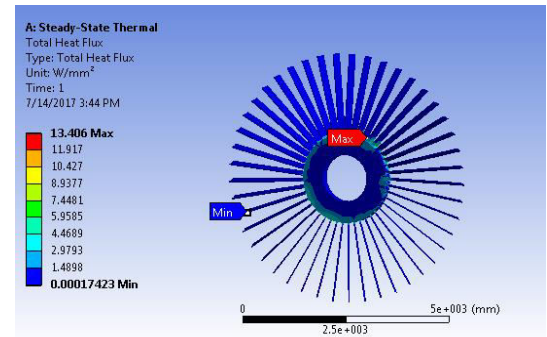
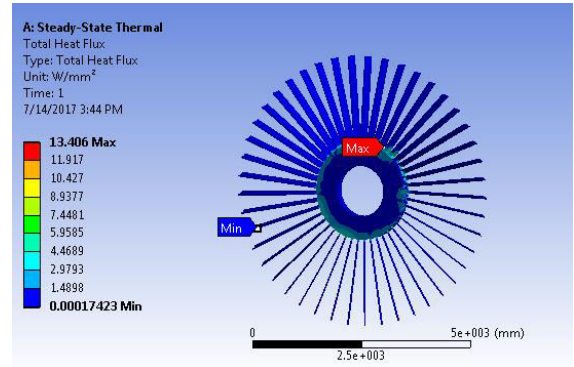

### Titanium material:

Thermal Conductivity	2.1e-002 W mm <sup>-1</sup> C <sup>-1</sup>
Density	4.5e-006 kg mm <sup>-3</sup>
Specific Heat	5.22e+005 mJ kg <sup>-1</sup> C <sup>-1</sup>

Object Name	Temperature	Total Heat Flux	Thermal Error
Minimum	556.57 °C	1.7423e-004 W/mm <sup>2</sup>	1184.6
Maximum	33720 °C	13.406 W/mm <sup>2</sup>	1.5536e+011

### Nickel material:

Thermal Conductivity	9.e-002 W mm <sup>-1</sup> C <sup>-1</sup>
Density	8.9e-006 kg mm <sup>-3</sup>
Specific Heat	4.44e+005 mJ kg <sup>-1</sup> C <sup>-1</sup>

Object Name	Temperature	Total Heat Flux	Thermal Error
Minimum	1103.5 °C	6.3098e-005 W/mm <sup>2</sup>	417.08
Maximum	8992.8 °C	17.989 W/mm <sup>2</sup>	3.8039e+010

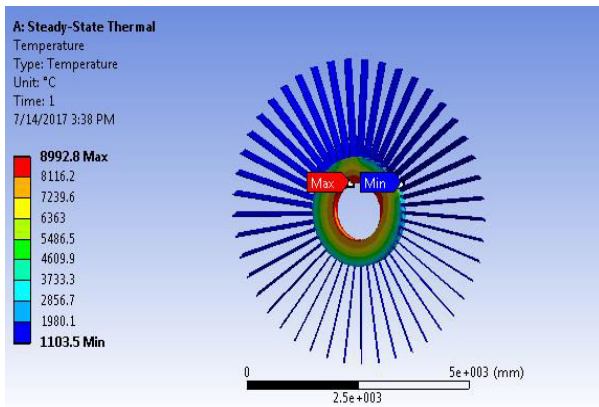

### Magnesium Alloy:

Density	1.8e-006 kg mm <sup>-3</sup>
Coefficient of Thermal Expansion	2.6e-005 C <sup>-1</sup>
Specific Heat	1.024e+006 mJ kg <sup>-1</sup> C <sup>-1</sup>
Thermal Conductivity	0.156 W mm <sup>-1</sup> C <sup>-1</sup>
Resistivity	7.7e-004 ohm mm

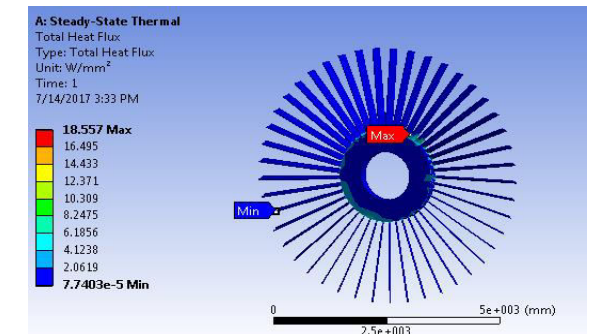
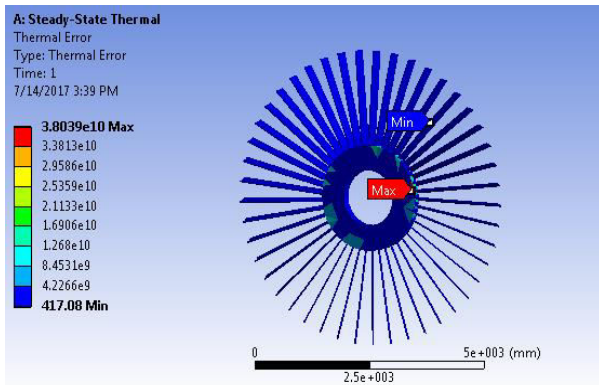
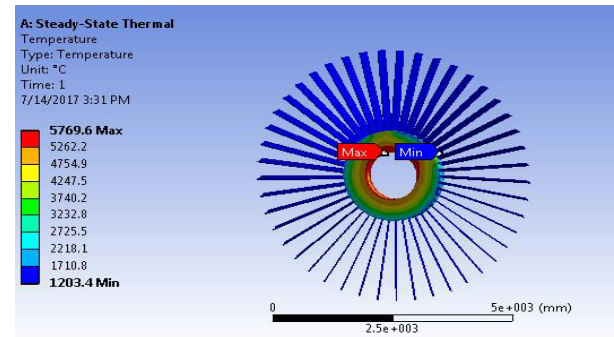
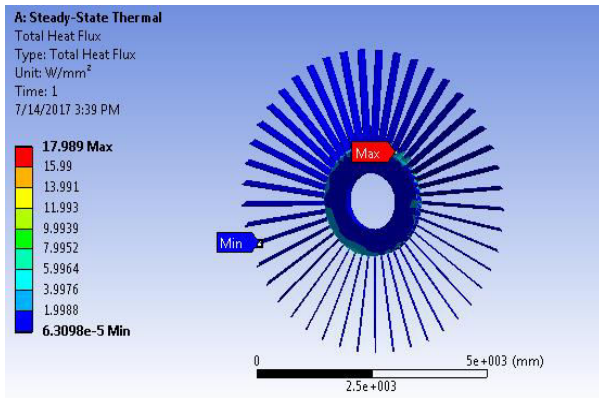

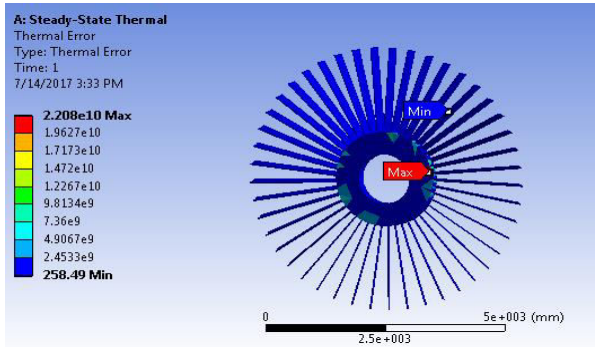

### Magnesium Alloy:

Temperature C	Young's Modulus Pa	Poisson's Ratio	Bulk Modulus Pa	Shear Modulus Pa
	4.5e+010	0.35	5.e+010	1.6667e+010

Object Name	Temperature	Total Heat Flux	Thermal Error
Minimum	1203.4 °C	7.7403e-005 W/mm <sup>2</sup>	258.49
Maximum	5769.6 °C	18.557 W/mm <sup>2</sup>	2.208e+010

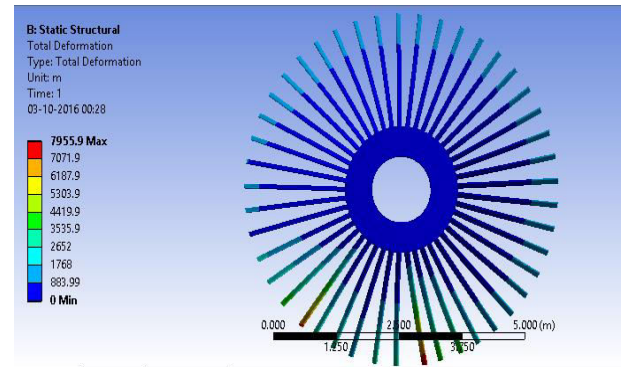

### Static Structural:

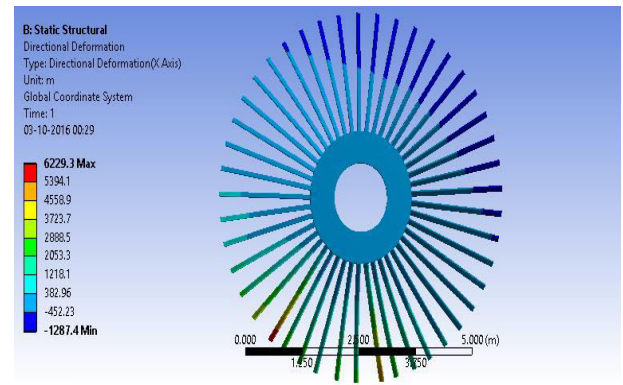
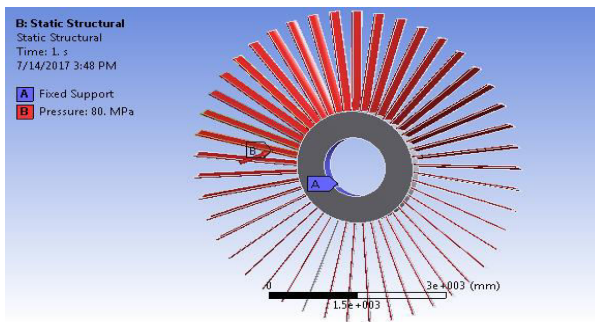

Type	Fixed Support	Pressure	Thermal Condition
Suppressed		No	
Define By		Normal To	
Magnitude		8.e+007 Pa (ramped)	1360. °C (ramped)

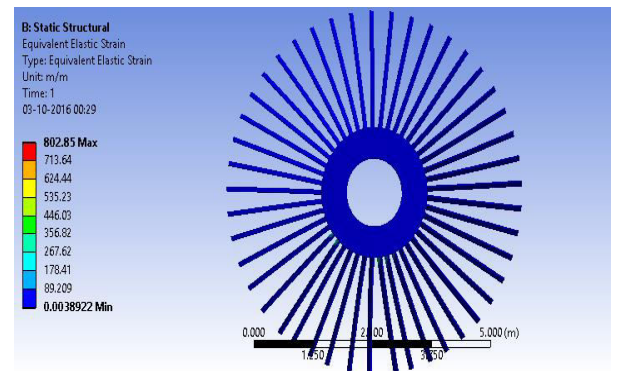



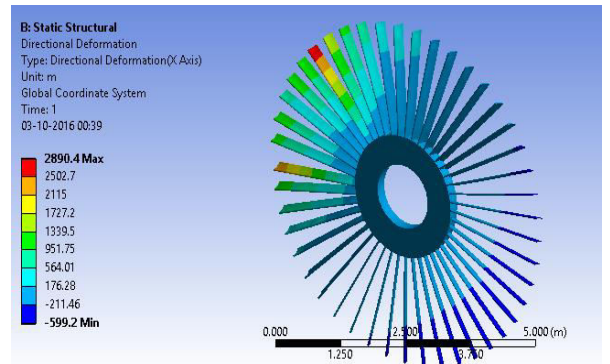
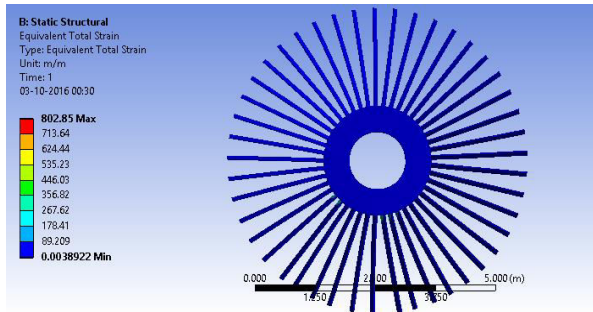
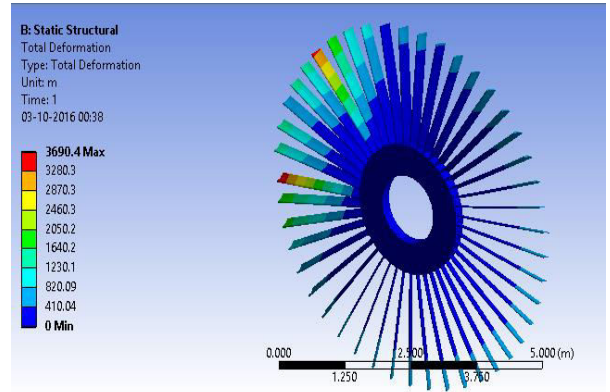
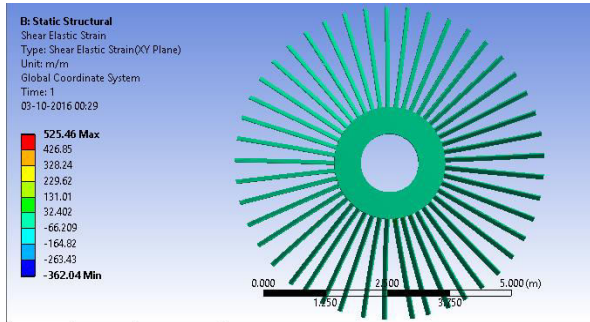

Object Name	Total Deformation	Directional Deformation	Equivalent Elastic Strain	Shear Elastic Strain	Equivalent Total Strain
Minimum	0. m	-1287.4 m	3.892 2e-003 m/m	362.04 m/m	3.892 2e-003 m/m
Maximum	7955.9 m	6229.3 m	802.8 5 m/m	525.46 m/m	802.8 5 m/m

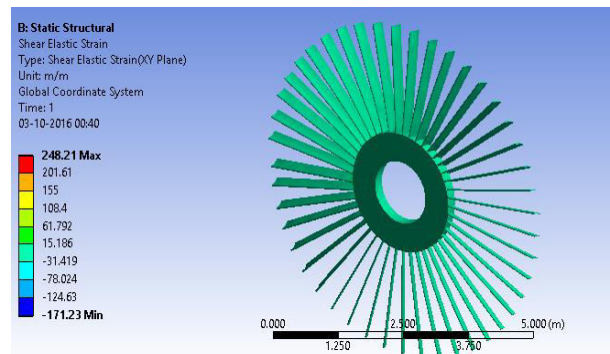
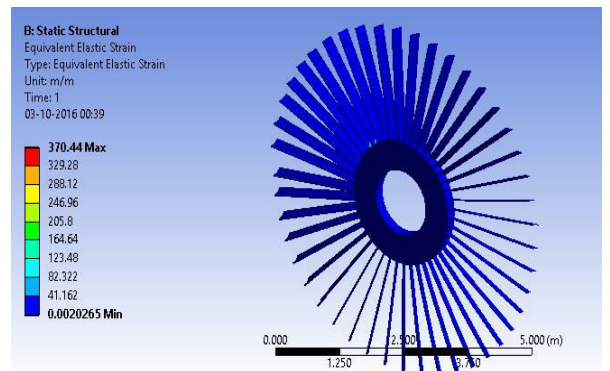

### Titanium Alloy:

Young's Modulus Pa	Poisson's Ratio	Bulk Modulus Pa	Shear Modulus Pa
9.6e+010	0.36	1.1429e+011	3.5294e+010

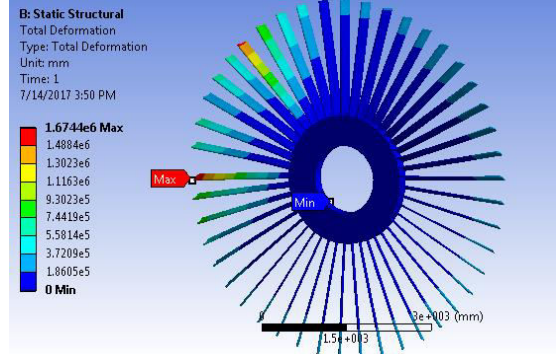
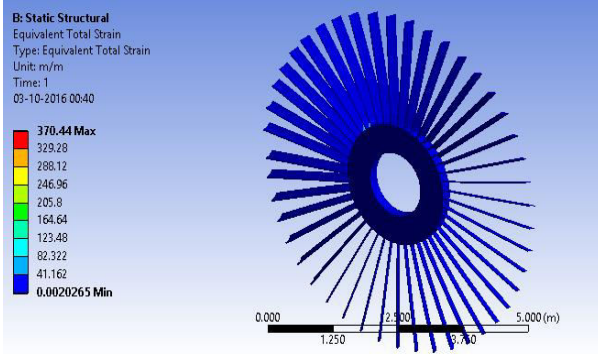

Object Name	Total Deformation	Directional Deformation	Equivalent Elastic Strain	Shear Elastic Strain	Equivalent Total Strain
Minimum	0. m	-599.2 m	2.0265e-003 m/m	171.23 m/m	2.0265e-003 m/m
Maximum	3690.4 m	2890.4 m	370.44 m/m	248.21 m/m	370.44 m/m

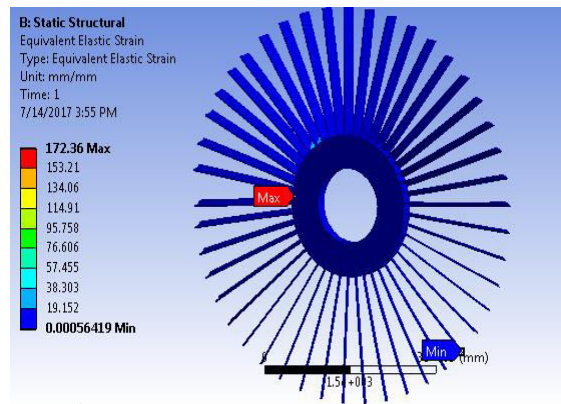
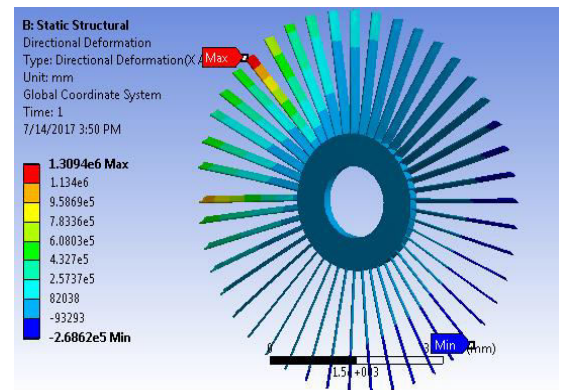

## Nickel

Temperature C	Young's Modulus Pa	Poisson's Ratio	Bulk Modulus Pa	Shear Modulus Pa
	2.2e+011	0.315	1.982e+011	8.365e+010

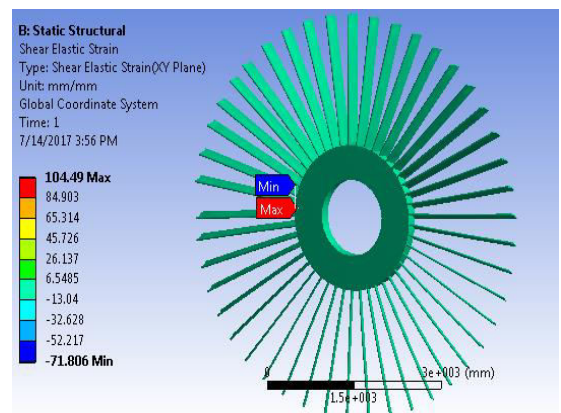

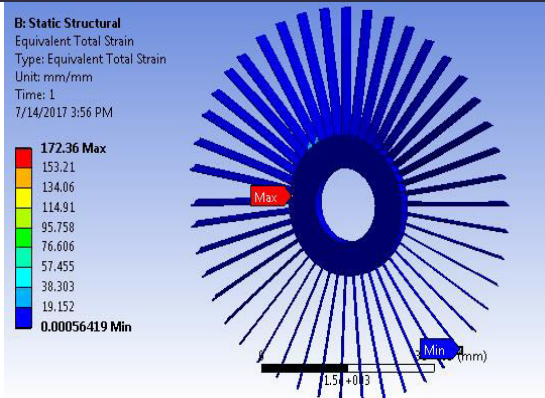

helix angle, force on the blade, material properties of the blade, speed of the turbine and etc. are various parameter important for the turbine blade condition.

3) They affect the blade life and efficiency of the plant in terms of mechanical properties and working condition.

4) The complex Design of blade will done in catia v5. Parametric software with coordinate point of tip and root section of blade.

Object Name	Total Deformation	Directional Deformation	Equivalent Elastic Strain	Shear Elastic Strain	Equivalent Total Strain
Minimum	0. m	-268.62 m	5.641 9e-004 m/m	71.8 06 m/m	5.641 9e-004 m/m
Maximum	1674.4 m	1309.4 m	172.3 6 m/m	104.49 m/m	172.3 6 m/m

### CONCLUSION:

1) There are many researches done on turbine blade in high-pressure stage or rotor section and work also done in steam and gas based power plant. But I found that are very few researches done work on last stage tangent-twisted blade of LP stage of turbine so we want to do research on this section. We like to use thermal and structural for analysis

2) Turbine blade type, flow of steam through impulse or reaction blade, geometry of blade,

### REFERENCES:

1. Darle W Dudley (1954), Practical Gear Design, McGraw-Hill Book Company.
2. Khurmi Gupta R S (2000), "Machine Design", Khanna Publication.
3. Khurmi R S (1997), "Theory of Machine", Khanna Publication.
4. Machine Design Data Book (2003), PSG Publication.
5. . Rattan S S (1998), "Theory of Machines", Dhanpat Rai Publication.
6. Romlay F R M (2008), "Modeling of a Surface Contact Stress for Spur Gear Mechanism Using Static and Transient Finite Element Method", Journal of Structural Durability & Health Monitoring (SDHM), Vol. 4, No. 1, Tech Science Press.
7. Shanavas S (2013), "Stress Analysis of Composite Spur Gear", International Journal of Engineering Research & Technology (IJERT), ISSN: 2278-0181
8. Shinde S P, Nikam A and Mulla T S (2012), "Static Analysis of Spur Gear Using Finite Element Analysis", IOSR Journal of Mechanical and Civil



- Engineering (IOSR-JMCE), pp. 26-31, ISSN: 2278-1684.
9. Sushil Kumar Tiwari and Upendra Kumar Joshi (2012), "Stress Analysis of Mating Involute Spur Gear Teeth", International Journal of Engineering Research & Technology (IJERT), Vol. 1, No. 9, ISSN: 2278-0181.
  10. Vivek Karaveer, Ashish Mogrekar and Preman Reynold Joseph T (2013), "Modeling and Finite Element Analysis of Spur Gear", International Journal of Current Engineering and Technology, ISSN 2277-4106.
  11. V. Siva Prasad, Syed Altaf Hussain, V. Pandurangadu, K. Palani Kumar. Modeling and Analysis of Spur Gear for Sugarcane Juice Machine under Static Load Condition by Using FEA. International Journal of Modern Engineering Research (2012), 2(4):2862-2866.
  12. Maheeb Vohra, Prof. Kevin Vyas "Comparative Finite Element Analysis of Metallic and non Metallic spur gear", May-June 2014, IOSR Journal of Mechanical and Civil Engineering, 11(3):136-145.