



COPY RIGHT



ELSEVIER
SSRN

2021 IJIEMR. Personal use of this material is permitted. Permission from IJIEMR must be obtained for all other uses, in any current or future media, including reprinting/republishing this material for advertising or promotional purposes, creating new collective works, for resale or redistribution to servers or lists, or reuse of any copyrighted component of this work in other works. No Reprint should be done to this paper, all copy right is authenticated to Paper Authors

IJIEMR Transactions, online available on 29th Aug 2021. Link

[:http://www.ijiemr.com/downloads.php?vol=Volume-10&issue=ISSUE-08](http://www.ijiemr.com/downloads.php?vol=Volume-10&issue=ISSUE-08)

DOI: 10.48047/IJIEMR/V10/I08/7

Title:- A NOVEL ISOLATED MODULAR MULTILEVEL DC-DC CONVERTER FOR HIGH VOLTAGE GAIN USING PV AS SOURCE

Volume 10, Issue 08, Pages: 41-47

Paper Authors

¹K. VENKATA KALYAN, ²RAJU LAKSHMANA REDDY

Editor IJIEMR



www.ijiemr.com

To Secure Your Paper As Per **UGC Guidelines** We Are Providing A Electronic Bar Code

A NOVEL ISOLATED MODULAR MULTILEVEL DC-DC CONVERTER FOR HIGH VOLTAGE GAIN USING PV AS SOURCE

¹K. VENKATA KALYAN, ²RAJU LAKSHMANA REDDY

¹M-tech student Scholar, Department of Electrical & Electronics Engineering, Velaga Nageswara Rao College of Engineering, Ponnuru; Guntur (Dt); A.P, India.

²M-Tech, Associate Professor, Department of Electrical & Electronics Engineering, Velaga Nageswara Rao College Of Engineering, Ponnuru; Guntur (Dt); A.P,

Abstract- The proposed concept gives the analysis and design of a line interactive uninterruptible power supply (UPS) connected to a Microgrid through a high step-up/down (bidirectional) dc-dc isolated modular multilevel converter with a high input to output voltage ratio. Resonant switching is used on the MMC to improve overall efficiency of the converter. The input source for this converter is a set of series and parallel batteries and the output of the converter is connected to a Microgrid. The proposed converter steps up the input voltage with a 1:15 conversion ratio, and steps down the input voltage with a 15:1 conversion ratio. A transformer is used to both isolate the converter and to further increase the step-up/down ratio. This type of systems is very much useful in renewable energy source applications for better efficiency and high voltage gain.

I.INTRODUCTION

Recently, there has been increased use of Microgrid systems that can supply the load from renewable energy to the load with high quality [1]. The power from renewable energy can be supplied to the load, or it could be saved depending on the power flow situation. Some renewable energy systems have limitations related to low voltage. For instance, the battery energy storage system, supercapacitor, and photovoltaic cells generate low voltage levels, and they cannot be connected directly to the load bus. To solve this connection problem, power electronics can be employed to connect the renewable energy to the load. Therefore, a converter could be used to boost the input voltage to meet the load bus or transmission line requirements. For these typical low-voltage problems, a high step-up/down converter becomes one of the most important and significant solutions for interfacing microgrid systems [2].

Battery energy storage systems are a good solution to increase grid reliability. The energy can be stored for later use during grid-connection mode, and energy storage systems can supply the power to the grid when a fault occurs in the grid. To connect energy storage systems to the grid, dc-dc buck-boost converters are normally used [3]. With medium and high voltage grids, bidirectional dc-dc transformer converters could be used to step up and step down the voltages. Researchers have been working on and improving modular multilevel converters (MMCs) for more than 30 years. This technology has been successfully used in the industry for years and is considered a trusted technology [4]. The significance of MMCs has been increasing among the other types of multilevel converters. This is because MMCs are proven to be more appropriate for utilization in medium-voltage and high-voltage applications, which are at variance with low-power applications, where topologies that include transformers

are found to be more effective in terms of conversion ratios [4]-[12].

This paper discusses a high step-up/down isolated modular multilevel converter for an uninterruptible power supply (UPS) system. For the UPS, there are two modes: grid-connection mode and stand-alone mode. In grid connection mode, power from the grid can charge batteries. In this grid-connection mode, the isolated MMC also works as a step-down converter with a 15:1 voltage conversion ratio. In the second mode, stand-alone mode, power can flow from the batteries to the grid. During this mode, the converter steps up the input voltage with a 1:15 voltage conversion ratio. In stand-alone mode power flow is also controlled by using a voltage and frequency drooping method. This ensures seamless transfer between the two conversion modes. Detailed MATLAB-Simulink simulations are presented and indicate the benefits of the proposed converter.

II. SYSTEM CONFIGURATION

The overall system is shown in Fig. 1. It has a set of parallel- and series-connected batteries as an input, a bidirectional high step-up/down isolated MMC converter, and a three phase bidirectional dc-ac inverter. Depending on the load condition, the high step-up/down can boost, or buck the voltage. In other words, the MMC can charge the batteries in battery charging mode, and it can operate as a step-up converter during discharging mode. The UPS is controlled based on the droop method.

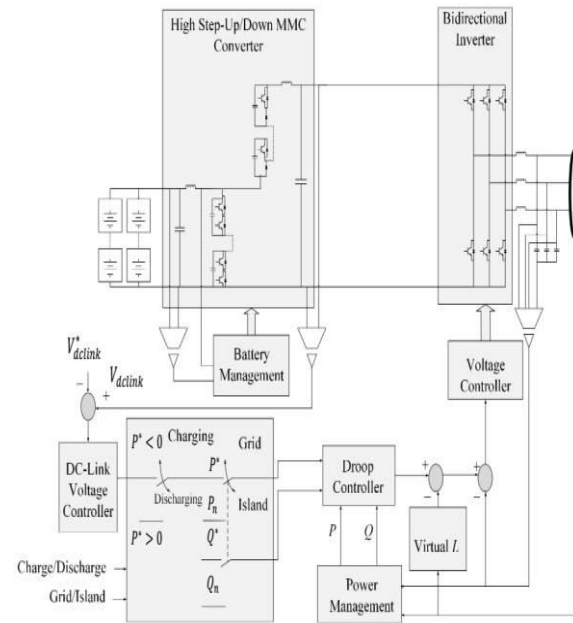

Fig.1. The overall control system with proposed converter

III. CONVERTER DESIGN

The topology that is described in [15] is for a transformer less modular multilevel converter where the transformer less MMC circuit system consists of an upper and lower set of capacitor-transistor cells, where the number of upper capacitor-transistor cells is N and the number of the lower capacitor-transistor cells is M [15], as shown in Fig. 2. Phase shift pulse width modulation (PSPWM) with a high duty cycle is used with the proposed MMC. This high duty cycle ensures that all except one of the capacitors are connected at any given time. This means that at any instance the pulse-width modulation method ensures all of the upper and lower capacitors (except one of them) are in series with the high side inductor and capacitor. However, for isolation purposes, a transformer is placed between the upper and lower cells. The transformer ensures that there is no direct connection between the input and the output. In addition, the transformer can provide some additional voltage increase

on the output. Fig. 3 shows an isolated high step-up modular multilevel converter.

For a transformer less MMC, the voltage and current conversion ratio equations are written in [15] as:

$$\frac{v_H}{v_L} = \frac{N}{1-d} \quad (3.1)$$

The current for this converter design is then derived [16]

$$I_L = \frac{v_H}{v_L} I_o \quad (3.2)$$

where v_H is the output voltage, v_L is the input voltage, d is the duty cycle, I_L is the input current, and I_o is the output current. From (2), the voltage conversion ratio depends on both the number of the upper cells, N , and the duty cycle d . To have a 1:10 conversion ratio, the number of the upper cells sets to be 4, and the duty cycle 0.6. Both equations (1) and (2) have the same expression for an isolated MMC. The only difference is that the turns ratio for the transformer should be included in the voltage and current conversion ratio equations. In other words, the voltage and current conversion ratio for an isolated topology can be written as:

$$\frac{v_H}{v_L} = \left(\frac{N_s}{N_p} \right) \frac{N}{1-d} \quad (3.3)$$

$$I_L = \left(\frac{N_p}{N_s} \right) \frac{N}{1-d} I_o \quad (3.4)$$

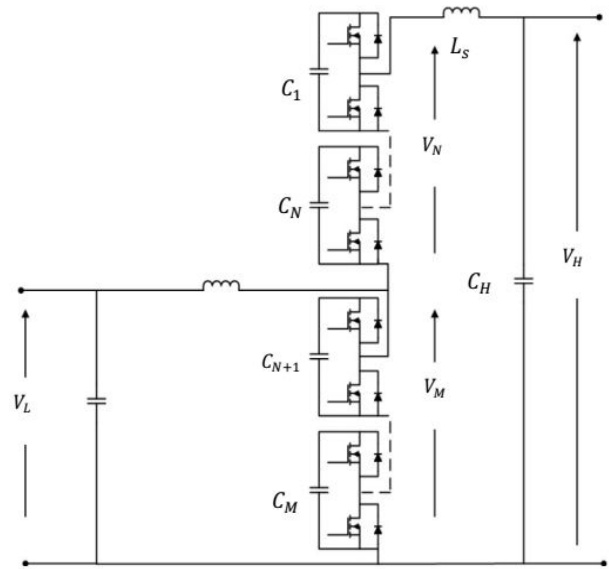

Fig.2. A high step-up modular multilevel converter [15].

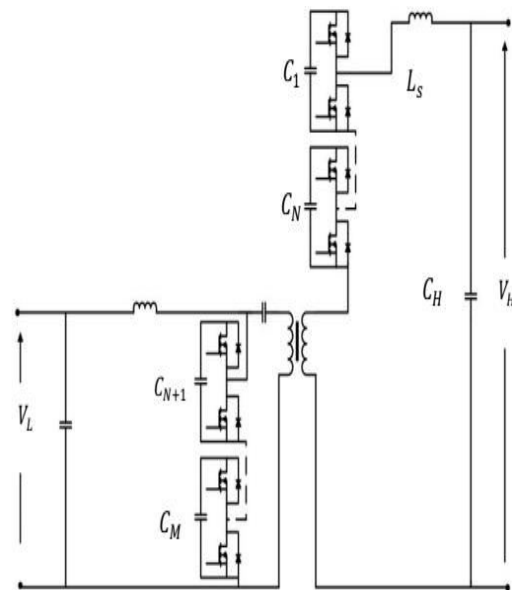

Fig.3. The proposed isolated modular multilevel converter

Where N_p and N_s are the number of the turns in the primary and secondary winding of the transformer, respectively. As mentioned earlier, the transformer less MMC can achieve 1:10 conversion ratio. However, the conversion ratio could be increased to 1:15 by using a transformer.

A **grid-connected photovoltaic power system** or **grid-connected PV system** is an electricity generating system that is connected to the utility grid. A grid-connected PV system consists of solar panels, one or several inverters, a power conditioning unit and grid connection equipment. They range from small residential and commercial rooftop systems to large utility-scale solar power stations. Unlike stand-alone power systems, a grid-connected system rarely includes an integrated battery solution, as they are still very expensive. When conditions are right, the grid-connected PV system supplies the excess power, beyond consumption by the connected load,

Residential, grid-connected rooftop systems which have a capacity more than 10 kilowatts can meet the load of most consumers.^[2] They can feed excess power to the grid where it is consumed by other users. The feedback is done through a meter to monitor power transferred. Photovoltaic wattage may be less than average consumption, in which case the consumer will continue to purchase grid energy, but a lesser amount than previously. If photovoltaic wattage substantially exceeds average consumption, the energy produced by the panels will be much in excess of the demand. In this case, the excess power can yield revenue by selling it to the grid. Depending on their agreement with their local grid energy company, the consumer only needs to pay the cost of electricity consumed less the value of electricity generated. This will be a negative number if more electricity is generated than consumed.^[3] Additionally, in some cases, cash incentives are paid from the grid operator to the consumer. Connection of

the photovoltaic power system can be done only through an interconnection agreement between the consumer and the utility company. The agreement details the various safety standards to be followed during the connection.

IV. MATLAB/SIMULINK RESULTS

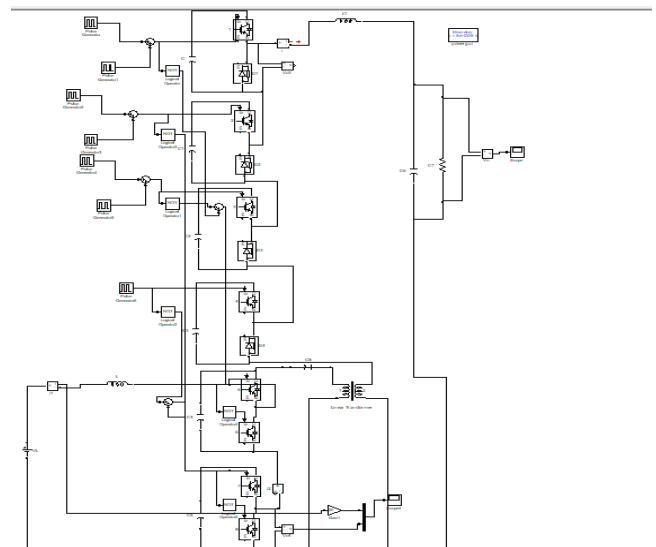

Fig.1: Simulation model of A high step-up modular multilevel converter

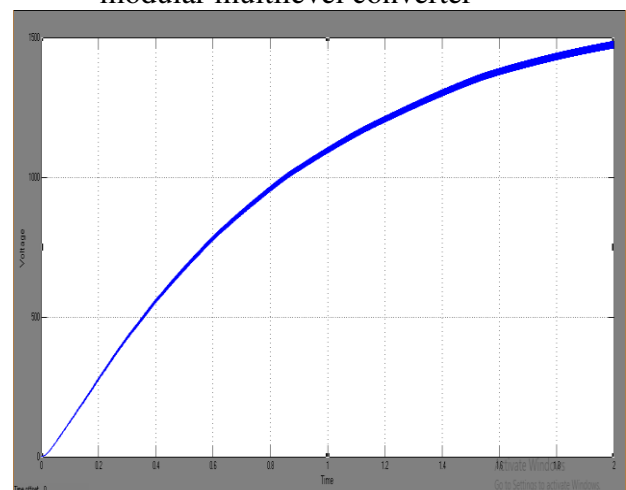

Fig2.Simulation waveform of output voltage

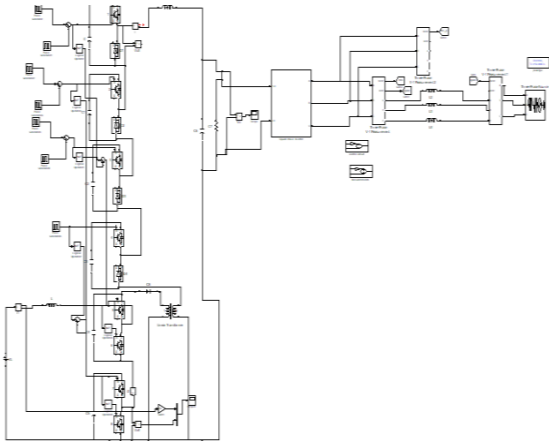

Fig.3: Simulation modelling of A high step-up modular multilevel converter

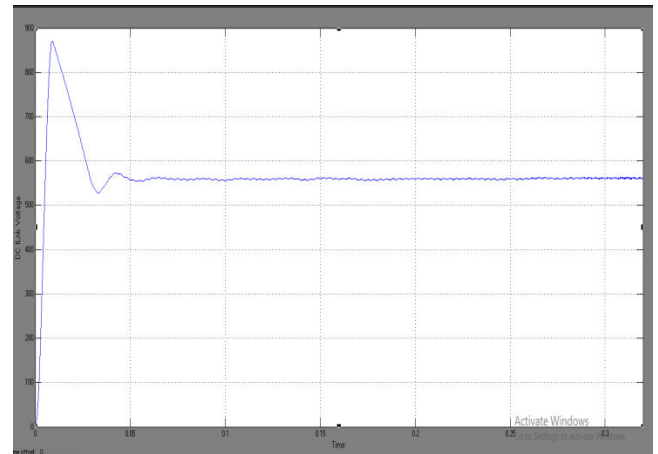

Fig6: Simulation waveform of inverse voltage discharging to charging mode.

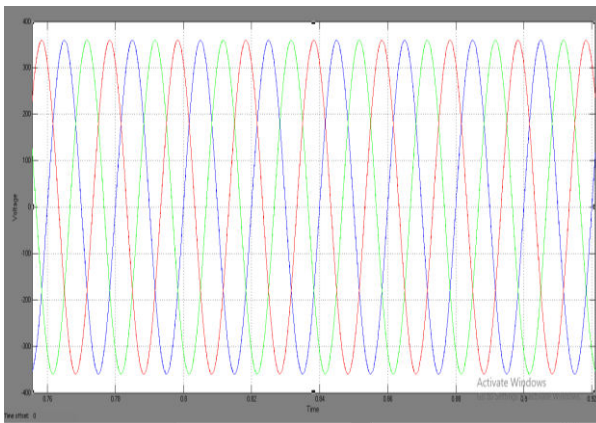

Fig4:Simulation waveform of gain voltage discharging to charging mode.

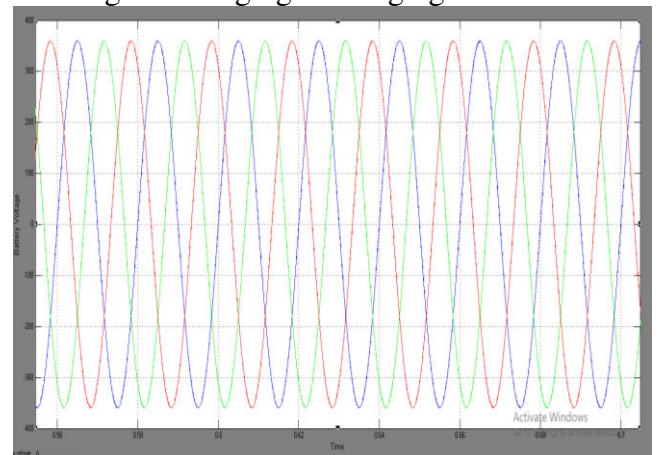

Fig7: Simulation waveform of gain voltage charging to discharging mode

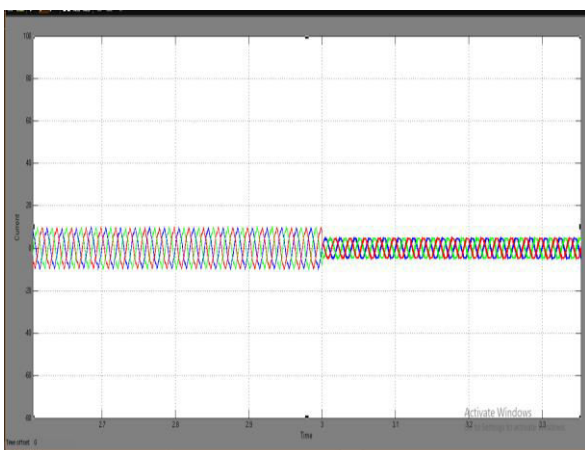

Fig5: Simulation waveform of gain current discharging to charging mode.

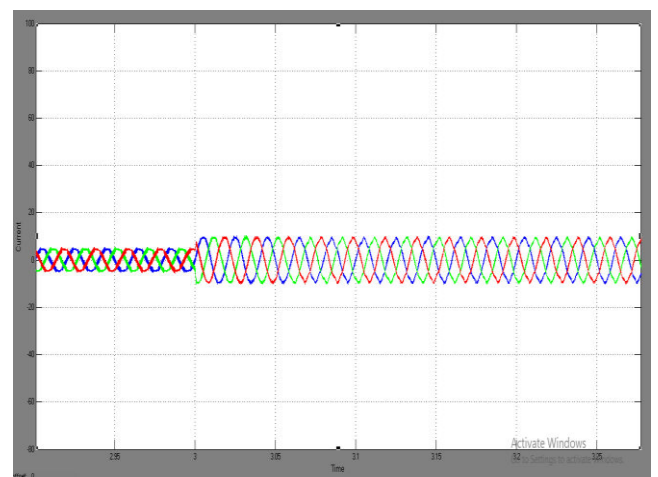

Fig 8: Simulation waveform of gain current charging to discharging mode.

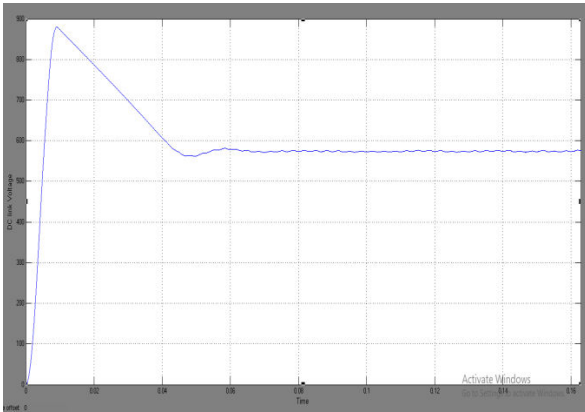

Fig:9 Simulation waveform of inverse voltage charging to discharging mode

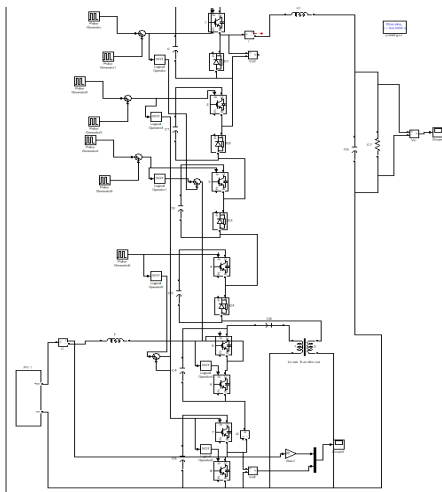

Fig:10:Simulation modelling of High step up modular multilevel converter is integrated with PV

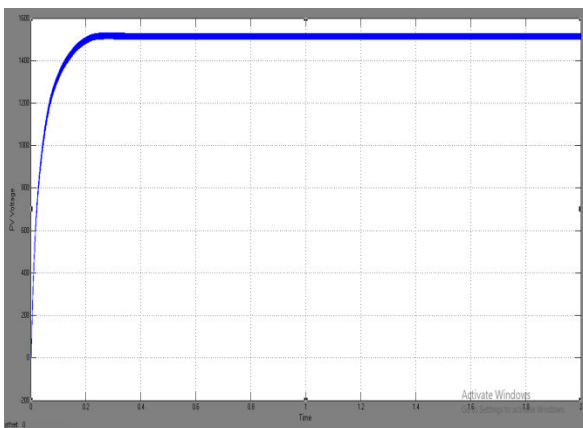

Fig.11: Simulation Waveform of output voltage with PV

CONCLUSION

A high step-up/down converter was integrated with a line uninterruptible power supply system and evaluated through simulation for stability, response and efficiency. With the appropriate control, the proposed MMC can make use of low-voltage input voltage sources, such as batteries and photovoltaic devices, and connect them to a medium/high voltage microgrid. The system can generate power flow from ac to dc or from dc to ac in either direction depending on the power flow situation. The voltage amplification ratio up to 1:10 can be achieved without the need for a transformer, and an even higher voltage step-up (1:15 ratio) is possible with a transformer. The use of a transformer would also provide galvanic isolation. This isolation would prevent (1) current flow between the circuits, (2) circulating currents if the ground potentials of both sides may differ and (3) dangerous passing of current through someone who comes in contact with the circuit.

This MMC therefore is practical and flexible for inexpensive low-voltage Microgrid connections. The MMC requires relatively simple cascaded control to achieve a response that is not far too slow for a better controller to correct. However, the response would be improved if it were made to be faster. The transient response is just under half a cycle (less than 25 ms), but a response of 7 ms or less is preferred, as typical faults and surges can become very problematic if they last more than about a quarter of the operating frequency on an ac line [17]. Future investigation into this MMC setup would include faster and more robust control to reduce the correction response time.

REFERENCES

- [1] M. Sahoo and K. S. Kumar, "High gain step up DC-DC converter for DC micro-grid application," Information and Automation for Sustainability (ICIAfS), 2014 7th International Conference on, Colombo, 2014, pp. 1-5.
- [2] T. J. Liang and J. H. Lee, "Novel High-Conversion-Ratio HighEfficiency Isolated Bidirectional DC-DC Converter," in IEEE Transactions on Industrial Electronics, vol. 62, no. 7, pp. 4492- 4503, July 2015.
- [3] M. A. Abusara, J. M. Guerrero and S. M. Sharkh, "Line-Interactive UPS for Microgrids," in IEEE Transactions on Industrial Electronics, vol. 61, no. 3, pp. 1292-1300, March 2014.
- [4] S. Kouro, M. Malinowski, K. Gopakumar, J. Pou, L. Franquelo, B. Wu, J. Rodriguez, M. Perez, and J. Leon, "Recent Advances and Industrial Applications of Multilevel Converters," in IEEE Transactions on Industrial Electronics, vol. 57, no. 8, pp. 2553- 2580, Aug. 2010.
- [5] J. I. Leon, S. Kouro, S. Vazquez, R. Portillo, L. G. Franquelo, J. M Carrasco, and J. Rodriguez, "Multidimensional Modulation Technique for Cascaded Multilevel Converters," in IEEE Transactions on Industrial Electronics, vol. 58, no. 2, pp. 412-420, Feb. 2011.
- [6] M. A. Perez, S. Bernet, J. Rodriguez, S. Kouro and R. Lizana, "Circuit Topologies, Modeling, Control Schemes, and Applications of Modular Multilevel Converters," in IEEE Transactions on Power Electronics, vol. 30, no. 1, pp. 4-17, Jan. 2015.
- [7] J. A. Ferreira, "The Multilevel Modular DC Converter," in IEEE Transactions on Power Electronics, vol. 28, no. 10, pp. 4460-4465, Oct. 2013.
- [8] M. A. Perez, E. Fuentes and J. Rodriguez, "Predictive current control of ac-ac modular multilevel converters," Industrial Technology (ICIT), 2010 IEEE International Conference on, Vi a del Mar, 2010, pp. 1289-1294.
- [9] E. Solas, G. Abad, J. A. Barrena, S. Aurtenetxea, A. Cárcar and L. Zajc, "Modular Multilevel Converter With Different Submodule Concepts—Part I: Capacitor Voltage Balancing Method," in IEEE Transactions on Industrial Electronics, vol. 60, no. 10, pp. 4525- 4535, Oct. 2013.
- [10] Liu, G., Jiang, Q., Wei, Y, "Study on Capacitor Voltage Balancing Control of Modular Multilevel Converter at Low Frequency," in International Journal of Computer and Electrical Engineering, vol.5, No.2, Apr. 2013.