



# International Journal for Innovative Engineering and Management Research

A Peer Reviewed Open Access International Journal

www.ijiemr.org

**COPY RIGHT**



**ELSEVIER**  
**SSRN**

**2022 IJIEMR.** Personal use of this material is permitted. Permission from IJIEMR must be obtained for all other uses, in any current or future media, including reprinting/republishing this material for advertising or promotional purposes, creating new collective works, for resale or redistribution to servers or lists, or reuse of any copyrighted component of this work in other works. No Reprint should be done to this paper, all copy right is authenticated to Paper Authors

IJIEMR Transactions, online available on 30th Jul 2022. Link

[:http://www.ijiemr.org/downloads.php?vol=Volume-11&issue= Spl Issue 06](http://www.ijiemr.org/downloads.php?vol=Volume-11&issue= Spl Issue 06)

**DOI: 10.48047/IJIEMR/V11/SPL ISSUE 06/30**

Title **VOICE CONTROLLED CAR USING ARDUINO AND BLUETOOTH MODULE**

Volume 11, SPL ISSUE 06, Pages: 161-166

Paper Authors

**Lalitha P, Abhilash S, Sai P, Sai Kumar B**



USE THIS BARCODE TO ACCESS YOUR ONLINE PAPER

To Secure Your Paper As Per **UGC Guidelines** We Are Providing A Electronic Bar Code

## VOICE CONTROLLED CAR USING ARDUINO AND BLUETOOTH MODULE

Lalitha P<sup>1</sup>, Abhilash S<sup>2</sup>, Sai P<sup>3</sup>, Sai Kumar B<sup>4</sup>

<sup>1</sup>Assistant Professor, Dept. of Electronics & Communication, Balaji Institute of Technology & Science, Warangal, Telangana, India

<sup>2,3,4</sup>UG Student, Dept. of Electronics & Communication, Balaji Institute of Technology & Science, Warangal, Telangana, India

**ABSTRACT:** *It is a robotic car, which works according to the voice of humans through the Bluetooth Module as a command. Because this robotic car has an HC-05 Bluetooth module which connects to any Android device and performs the same functions by converting the voice which is given the command such as right, left, forward, back and stop etc. Here is a robotic car device that works on the voice of human. Many devices have been used in this robotic car, out of them Arduino Uno chip is more important and special, so we have named our project it, "Arduino based voice control car". As we mentioned, many devices have been used in this, each device has its own specialty. Those complete their work accordingly and this project as well Arduino based voice control car is much useful for those areas where humans can't reached. Robot can work in all type of situation like polluted area, In the midst of bullets, finding bombs, toxic area, in fire situation and also on hills. This robotic car is very useful for those who are physically handicapped. This robotic car is small in size so we can use this project for spying or espial, implement in this project so we can use this robotic car in military application, police, agriculture purpose, industrial purpose, playing for kids and also for surveillance devices.*

**Keywords:** Arduino Uno, Bluetooth, Robot, Voice and Android.

### 1. INTRODUCTION

In this project, the robot control car basically works on human speech command. We can say wireless Bluetooth robot, the android application is installed in our Smartphone which works as a transmitter [12]. The commands are given by this android application. The robotics car can be controlled wireless voice commands directly from the user. The robot can move forward, backward, left, right, stop and rotation can also be stopped. The Arduino based voice control car is interfaced with a

Bluetooth module HC05 which is connected to the Arduino [13].

The car can be moved easily from one location to another location. The car will be moving according to the voice commands given by the user [14]. This can be moved in forward - move the car in forward direction, Backward – move the car in Backward direction, left – move the car in left direction, and right – move the car in right direction, stop – stop the car, rotation – rotate the car according to the different commands given by the user. As we know that Arduino is programmable, so we have to do the programming using C or JAVA language. When the programming is of Arduino is done, we connect all the connection as required for the robot. Here is a robotic car device that works on the voice of human [15]. We connect android application (AMR\_voice and Arduino Bluetooth controller app.) and Bluetooth module (HC-05) using Bluetooth link. The commands are given by the AMR voice and Arduino Bluetooth controller by the user [16]. The command by the user is converted into digital form. The range of this robot is up to 50 meter. Push button is use to change the rotation direction. If we want to make this for a certain purpose the range can be increase [17]. These commands are received by Bluetooth module and Arduino perform the operation according to the given commands the given commands by the user is converted into digital form [18]. Here the circuit design is used to L298N motor driver, a Bluetooth module HC-05, a 300 RPM gear motor, a power supply battery (6 volt and 9 volt), jumper wires a ultrasonic sensor, a Potentiometer, a Push button and an Arduino Uno board etc.

## 2. SYSTEM MODEL

In the system model the block diagram of this project figure. This project based on a Bluetooth android application, Arduino UNO and motor driver in the paper robot control through the Arduino Bluetooth device by the Bluetooth application [19]. It project control by the voice command through Arduino UNO and Bluetooth technique, and it is easily can perform when user given the command via Bluetooth then Arduino UNO accept the command and perform to result according command [20]. If we request perform to right movement the result will show robot car will be perform right movement. Motor driver connected to the Arduino UNO via motor driver pin No. In1 connect to the Arduino Uno pin No.4, Motor driver pin No. In2 connect to the Arduino Uno pin No.5, Motor driver pin No. In3 connect to the Arduino Uno pin No.6, Motor driver pin no In4 connect to the Arduino Uno pin Mo.8,.HC-05 Bluetooth module and Arduino UNO connected via Bluetooth pin name TXD connect to the Arduino pin name RXD, Bluetooth pin name RXD connect to the Arduino pin name TXD, Bluetooth pin name GND connect to the Arduino Pin Name GND, Bluetooth pin name VCC connect to the Arduino Pin Name 5V.

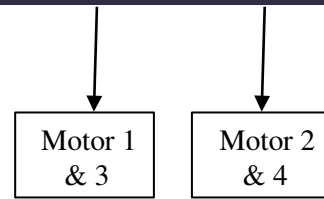
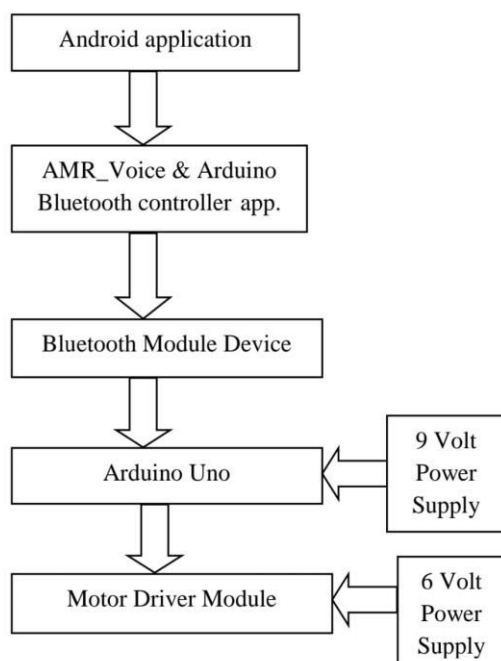

Fig 2.1:- Block Diagram of Arduino Based Voice Control Car

## 3. PREVIOUS WORK

This project of a simple voice control robotics car it connect to the Arduino UNO Bluetooth via Bluetooth module App.Motor Driver connected to the Arduino UNO via model driver pin name In 1 connect to the Arduino pin No.4, model driver pin name In 2 connect to the Arduino pin No.5, model driver pin name In 3 connect to the Arduino pin No.6, model driver pin name In 4 connect to the Arduino pin No.8. Robotics car controlled by the Arduino UNO and Bluetooth And Arduino and Arduino UNO connected to the Bluetooth module connect via Arduino pin name TXD connect to Bluetooth pin name RXD, Arduino pin name GND connect to Bluetooth pin name GND, Arduino pin name RXD connect to Bluetooth pin name TXD Arduino pin name VCC connect to Bluetooth pin name 5V. User given the command in Bluetooth application and Bluetooth connect to Arduino UNO so Robotics car receive the command by Arduino UNO.If user say move left Arduino accept command and move left.The robotics car can move command left, right & around [21].

## 4. PROPOSED METHODOLOGY

Hardware and Software Requirements:-

1. Arduino Uno:- Arduino Uno is perform important role in the project because all over project based on a Arduino UNO. It is used in programming and software field Arduino has become very popular in the world in recent times. Arduino fast wiring & processing projects. Motor driver connected to the Arduino UNO via Motor driver pin name In1 connected to Arduino Uno pin No. 4, Motor driver pin name In2 connected to Arduino Uno pin No.5, Motor driver pin name In3 connected to Arduino Uno pin No.6, Motor driver pin name In4 connected to Arduino Uno pin No.7.Arduino is an open-source electronics platform based on easy-to-use hardware and software. Arduino boards are able to read inputs - light on a sensor, a finger on a button, or a Twitter

message and turn it into an output - activating a motor, turning on an LED, publishing something online. You can tell your board what to do by sending a set of instructions to the microcontroller on the board. To do so you use the Arduino programming language (based on Wiring), and the Arduino Software (IDE), based on Processing. Over the years Arduino has been the brain of thousands of projects, from everyday objects to complex scientific instruments. A worldwide community of makers - students, hobbyists, artists, programmers, and professionals - has gathered around this open-source platform, their contributions have added up to an incredible amount of accessible knowledge that can be of great help to novices and experts alike [22]. Arduino was born at the Ivrea Interaction Design Institute as an easy tool for fast prototyping, aimed at students without a background in electronics and programming. As soon as it reached a wider community, the Arduino board started changing to adapt to new needs and challenges, differentiating its offer from simple 8-bit boards to products for IoT applications, wearable, 3D printing, and embedded environments. All Arduino boards are completely open-source, empowering users to build them independently and eventually adapt them to their particular needs [23]. The software, too, is open source, and it is growing through the contributions of users worldwide.

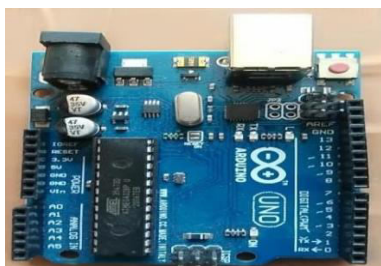

Fig. 4.1 Arduino Uno

2. Motor Driver: The L298N is a dual H-Bridge motor which allows speed and direction control of two DC motors at the same time. Microcontrollers are not compatible with motors directly. These circuits can be use motion and rotate motors. The module has two screw terminal blocks for the motor A and B and the power supply 6 Volt one is ground and second one is positive It is used to motor driver pin In1, In2, In3, In4, connected to Arduino uno board pin 4,5,6,7. Motor driver pin In1 is connect to Arduino uno pin 4, motor driver pin In2 is connect to Arduino uno pin 5, motor

driver pin In3 is connect to Arduino pin 6 and motor driver pin In4 is connect to Arduino uno pin 7, and a 300rpm gear motor and a 6 volt power supply battery. If the motor supply voltage is up to 3 Volt to 56 Volt we can enable the regulator.

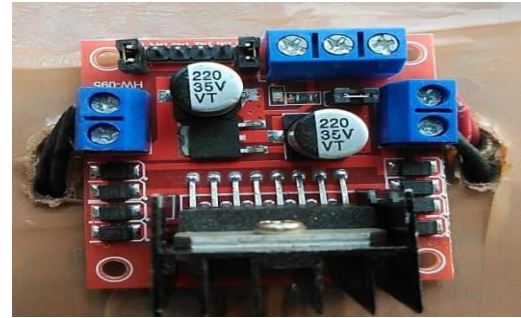

Fig 4.2 Motor Driver

3. Bluetooth Module: HC-05 Bluetooth module and Arduino UNO connected via Bluetooth pin name TXD connect to the Arduino pin name RXD, Bluetooth pin name RXD connect to the Arduino pin name TXD, Bluetooth pin name GND connect to the Arduino Pin Name GND, Bluetooth pin name VCC connect to the Arduino Pin Name 5V. For more information about HC-05 Bluetooth module and how to use it, refer the topic HC-05 Bluetooth module in the sensors and modules section. Default Bluetooth name of the device is "HC-05" and default PIN (password) for connection is either "0000" or "1234". Arduino UNO and motor driver In the project robot control through the Arduino Bluetooth device by the Bluetooth application. It project control by the voice command through Arduino UNO and Bluetooth technique, and it is easily can perform when user given the command via Bluetooth then Arduino UNO accept the command and perform to result according command.



Fig. 4.3 Bluetooth Module

4. Gear Motor: The gear motor works on the input of motor driver. And this gear motor rotates clockwise and anticlockwise as well. Which is visible to us as Output similarly the gear motor can also be rotated Right, Left, Back, Forward and 360°. In this project the gear motor 300RPM are work on the 9 Volt power supply. The gear motor straight actuator and rotating actuator that takes into account exact control of wheels.



Fig 4.5 300 RPM Gear Motor

## SOFTWARE REQUIREMENTS

**The Android App:** In this project we are using the two Android applications. AMR\_Voice and Arduino Bluetooth controller application. Arduino uno board communication between motor driver via Bluetooth. We are using the HC05 Bluetooth module in the project. When the application is running in the Android phone the user voice orders are distinguished by the Android microphone.

**Arduino IDE:** In the software requirements the Arduino Integrated Development Environment (Arduino IDE) is a cross-stage application (for Windows, macOS, Linux, UNIX) that is written in the C, C++ and JAVA. In this utilized the project and compose the object and transfer projects to the Arduino based Voice Controlled Car maintaining the perfect sheets. C or Java Programming Language.

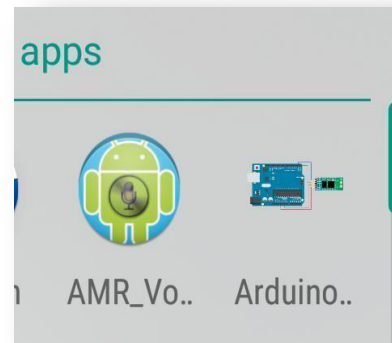

Fig 4.6 Application's

## 5. RESULT

The result of the project "Arduino based voice control car" is moving all the direction right, left, forward, back, 360° and stop. Here is a robotic car device that works on the voice of human commands via Google. Speeches recognize. The Arduino Bluetooth controller app. send a voice command as data Bluetooth module understand him to Arduino Uno chip and motor driver are run the wheels. It low power consumption and user friendly. Many devices have been used in this robotic car, out of them Arduino Uno chip is more important and special, so we have named our project it, "Arduino based voice control car". The advantage of this car is sent to such toxic place where humans cannot go, It can help to find terrorist without causing any loss of life or property. We are using a C programming language with serial libraries.

## 6. CONCLUSION

It is a robotic device will be control the human voice commanding through the Bluetooth module. This project works on human voice command with android application. It is easy to use for simple voice command forward, back, left, right, stop and rotation. The Arduino based voice control car is easily control to human voice controlling commands is successfully transmitted the signals. Voice control robot is much useful for that area where human cannot reach. This robotic car is small in size so we can use this project for spying or special, implement in this project so we can use this robotic car in police, agriculture purpose, military application, playing for kids, industrial purpose and also for surveillance devices. those complete their work accordingly and this project as

well as Arduino based voice control car. Our project designing to use for many devices in this robotic car.

The robotics car moves forward, backward, left, right, stop and rotation according to the voice commands forward, back, left, right, stop and rotation. These commands are read using an android application on the user's phone which is connected to the robot using a Bluetooth module (HC-05).

## 7. FUTURE SCOPES

It can also be modernized in future because it has many such devices which have their own characteristics. Which can also do more work, so that it can bring more modernity in the future as well As if you have seen its processing. This is a voice controlled car. If we see it in a larger format then it can be added to any car. And with this help, any physically handicapped person can control the car with his voice and run on the road. Because "Arduino based voice control car" gives it all the control. As if he can move the car with his voice, he also has many controls without any physical touch. They can also turn the car forward, back, right, left, stop and 360° angle or as much as they want. But some controls are also near the car which is connected to it due to Artificial Intelligence. For example, if something in the way while the car is running, using an ultrasonic sensor, the car automatic reduces its speed and stops the car. Its security system is also very much because it is always monitored by the camera installed in it. At present, the range of "Arduino based voice control car" is only 50 meters. But it can be further connected to wifi to extend its range to at least 1 kilometre. So that can be used to secure the border of our country, we can monitor and spy on the border. We can also use it in agriculture, such as to avoid the chaos of the chaotic creatures in the fields, and it can be used to protect the farm crop from any kind of damage. And in future it can be made even more excellent and useful.

## REFERENCES

- [1] Anjali Verma, Deepak Kumar, Hariom Maurya, Anuj Kumar, Mr. Prabhakant Dwivedi "VOICE CONTROL ROBOT USING ARDUINO" International Journal of Computer Science and Electronics Engineering (IJCSEE), vol. 07, Issue 05, pp. 2395, May 2020
- [2] Aarti Paswan1, Ajay Kumar Gautam2, Bhartendu Vimal3, Farheen4, Arun Kumar Mishra5 "Voice Controlled Robotic Vehicle" Ijsrr, Volume 07, Issue03, March 2019, Pp.1536.
- [3] Prof. Bhuvaneshwari Jolad1, Mohanish Arora2, Rohan Ganu3, Chetan Bhatia4 "Voice Controlled Robotic Vehicle" Irjet, Volume: 04, Issue: 06, June-2017, Pp 191-192.
- [4] P R Bhole1, N L Lokhande2, Manoj L Patel3, V D Rathod4, P R Mahajan5 "Voice Command Based Robotic Vehicle Control" Ijraset, Volume 5, Issue Xi, November 2017, Pp.1079.
- [5] Ayan Maity1, Avijit Paul1, Priyanka Goswami2, Ankan Bhattacharya1 "Android Application Based Bluetooth Controlled Robotic Car" Ijiis, Volume-6, Number-5 November 29, 2017, Pp.62-66.
- [6] Vladimir Cvjetkovic & Milan Matijevic, "Overview of architectures with Arduino boards as building blocks for data acquisition and control systems", 13th International Conference on Remote Engineering and Virtual Instrumentation (REV), pp. 56 – 63, February 2016.
- [7] Nelson Rai1, Deepak Rasaily2, Tashi Rapden Wangchuk3, Manoj Gurung4, Rit Kr. Khawas5 "Bluetooth Remote Controlled Car Using Arduino" Ijett, Volume 33, Number 8 March 2016, Page381.
- [8] K. Kannan1, Dr. J. Selvakumar2 "Arduino Based Voice Controlled Robot" Ijett, Volume: 02 Issue:01 March – 2015, Pp.49.
- [9] Zakariyya Hassan Abdullahi, Nuhu Alhaji Muhammad, Jazuli Sanusi Kazaure, and Amuda F.A., "Mobile Robot Voice Recognition in Control Movements", International Journal of Computer Science and Electronics Engineering (IJCSEE), vol. 3, Issue 1, pp. 11-16, 2015.
- [10] K. Kannan and D. Selvakumar, "Arduino Based Voice Controlled Robot", International Research Journal of Engineering and Technology (IRJET), vol. 02, no. 01, pp. 49-55, 2015.
- [11] Tatiana Alexenko, Megan Biondo, Deya Banisakher, Marjorie Skubic, "Android-based Speech Processing for ElderCare Robotics", IUI '13 Companion Proceedings of the companion publication of the 2013 international conference on Intelligent user interfaces companion, pp.87-88, March 2013.
- [12] Karthik Kumar Vaigandla, Dr.N.Venu, "Survey on Massive MIMO: Technology, Challenges, Opportunities and Benefits," YMER, VOLUME 20 : ISSUE 11 (Nov) - 2021, Page No:271-282.
- [13] Karthik Kumar Vaigandla and Dr.N.Venu, "A Survey on Future Generation Wireless Communications - 5G : Multiple Access Techniques, Physical Layer Security, Beamforming Approach", *Journal of Information and Computational Science*, Volume 11 Issue 9, 2021, pp.449-474.
- [14] Karthik Kumar Vaigandla and Dr.N.Venu, "BER, SNR and PAPR Analysis of OFDMA and SC-FDMA," GIS SCIENCE JOURNAL, ISSN NO : 1869-9391, VOLUME 8, ISSUE 9, 2021, pp.970-977.
- [15] Dr.Nookala Venu, Dr.A.ArunKumar and Karthik Kumar Vaigandla. Review of Internet of Things (IoT) for Future Generation Wireless Communications. International Journal for Modern Trends in Science and Technology 2022, 8(03), pp. 01-08.
- [16] A.V.L.N.Sujith, R.Swathi, R. Venkatam subramanian, Nookala Venu, S. Hemalatha, Tony George, A. Hemalathadhevi, P. Madhu, Alagar Karthick, M. Muhibbullah, Sameh M. Osman, "Integrating Nanomaterial and High-Performance Fuzzy-Based Machine Learning Approach for Green Energy Conversion" Journal of Nan materials, ISSN: 1687-4129, Volume 2022, PP:1-11.
- [17] Nookala Venu, D. Yuvaraj, J. Barnabas Paul Gladly, Omkar Pattnaik, Gurpreet Singh, Mahesh Singh, and Amsalu Gosu Adigo, "Execution of Multitarget Node Selection Scheme for Target Position Alteration Monitoring in MANET", Wireless Communications and Mobile Computing, ISSN:1530- 8669, Volume 2022, PP: 1-9.
- [18] Nookala Venu, R.Swathi, Sanjaya Kumar Sarangi, V. Subashini, D. Arulkumar, Shimpy Ralhan, Baru Debtera,



"Optimization of Hello Message Broadcasting Prediction Model for Stability Analysis", *Wireless Communications and Mobile Computing*, ISSN:1530- 8669, Volume 2022, PP: 1-9.

[19] Nookala Venu, Karthik Kumar Vaigandla, Dr.A.ArunKumar, "Investigations of Internet of Things (IoT): Technologies, Challenges and Applications in healthcare", *International Journal of Research (IJR)*, ISSN: 2236-6124, Volume XI, Issue II, Feb 2022, PP: 143-153

[20] Dr. Nookala Venu, "Analysis of Xtrinsic Sense MEMS Sensors" *International Journal of Advanced Research in Electrical, Electronics and Instrumentation Engineering (IAREEIE)*, ISSN:2278-8875 Vol 4, Issue:8, August 2015, PP: 7228-7234.

[21] Nookala Venu, Asiya Sulthana, "Local Mesh Patterns for Medical Image Segmentation" *Asian Pacific Journal of Health Sciences (APJHS)*, e-ISSN: 2349-0659 p-ISSN: 2350-0964, Vol. 5, Issue 1, March 2018, PP: 123-127.

[22] Dr Nookala Venu, Mrs Asiya Sulthana "Local Maximum Edge Binary Patterns for Medical Image Segmentation, *International Journal of Engineering and Techniques (IJET)*, ISSN: 2395-1303, Volume 4 Issue 1, Jan- Feb 2018, PP: 504-509.

[23] Dr.N.Venu, Dr.A.Arun Kumar, "Comparison of Traditional Method with watershed threshold segmentation Technique", *International Journal of Analytical and Experimental Analysis (IAEMA)*, ISSN: 0886-9367, Volume XIII, Issue 1, January-2021, PP:181-187.

[24] Karne, RadhaKrishna, and T. K. Sreeja. "ROUTING PROTOCOLS IN VEHICULAR ADHOC NETWORKS (VANETs)." *International Journal of Early Childhood* 14.03: 2022.

[25] Karne, RadhaKrishna, et al. "Optimization of WSN using Honey Bee Algorithm."

[26] RadhaKrishna Karne, Dr TK. "COINV-Chances and Obstacles Interpretation to Carry new approaches in the VANET Communications." *Design Engineering* (2021): 10346-10361.

[27] Karne, RadhaKrishna, et al. "Simulation of ACO for Shortest Path Finding Using NS2." (2021): 12866-12873.

[28] RadhaKrishna Karne, Dr TK. "Review On Vanet Architecture And Applications." *Turkish Journal of Computer and Mathematics Education (TURCOMAT)* 12.4 (2021): 1745-1749.

[29] Karne, Radha Krishna, et al. "GENETIC ALGORITHM FOR WIRELESS SENSOR NETWORKS."