



International Journal for Innovative Engineering and Management Research

A Peer Reviewed Open Access International Journal

www.ijiemr.org

COPY RIGHT

2017 IJIEMR. Personal use of this material is permitted. Permission from IJIEMR must be obtained for all other uses, in any current or future media, including reprinting/republishing this material for advertising or promotional purposes, creating new collective works, for resale or redistribution to servers or lists, or reuse of any copyrighted component of this work in other works. No Reprint should be done to this paper, all copy right is authenticated to Paper Authors

IJIEMR Transactions, online available on 9th July 2017. Link :

<http://www.ijiemr.org/downloads.php?vol=Volume-6&issue=ISSUE-5>

Title: A New Control Strategy of Two Shunt Connected Converters For Synchronized Supply Voltage And Grid Current Harmonic Compensation.

Volume 06, Issue 05, Page No: 1647 – 1651.

Paper Authors

* **SAYED JAVED, J.SRINIVASA RAO.**

* Dept of EEE, Anurag Engineering College.



USE THIS BARCODE TO ACCESS YOUR ONLINE PAPER

To Secure Your Paper As Per **UGC Guidelines** We Are Providing A Electronic Bar Code

A NEW CONTROL STRATEGY OF TWO SHUNT CONNECTED CONVERTERS FOR SYNCHRONIZED SUPPLY VOLTAGE AND GRID CURRENT HARMONIC COMPENSATION

***SAYED JAVED, **J.SRINIVASA RAO**

*PG Scholar, Dept of EEE, Anurag Engineering College.

**Assistant Professor, Dept of EEE, Anurag Engineering College.

Javeedsd220@gmail.com

janigasrinivasrao@gmail.com

ABSTRACT

This project presents the growing installation of distributed generation (DG) units in low voltage distribution systems has popularized the concept of nonlinear load harmonic current compensation using multi-functional DG interfacing converters. It is analyzed in this paper that the compensation of local load harmonic current using a single DG interfacing converter may cause the amplification of supply voltage harmonics to sensitive loads, particularly when the main grid voltage is highly distorted. The second converter is used to mitigate the harmonic current produced by the interaction between the first interfacing converter and the local nonlinear load.

Key Words: DG, Power quality, Harmonics, Converters

1. INTRODUCTION

In recent literature, an enhanced current controller utilizing the frequency selective feature of resonant controllers was proposed to remove both the load current harmonic extraction and the phase-locked loop in a single-phase DG unit. Nevertheless, it is important to emphasize that even when the local load harmonic current is properly compensated using various controllers as mentioned above, high quality supply voltage to local load cannot be guaranteed at the same time. This problem is particularly serious when the DG interfacing converter is interconnected to a weak microgrid with nontrivial upstream grid voltage

distortions. To overcome this limitation, the dynamics voltage restorer (DVR) with series harmonic voltage compensation capability can be installed in the power distribution system, as proposed in [3] and [4]. Unfortunately, the functionality of a DVR can hardly be implemented in a shunt DG interfacing converter. Using an additional series power conditioning equipment to ensure very low steady-state harmonic supply voltage to local loads is definitely feasible. However, it is associated with more expenses which might not be accepted for cost-effective power distribution systems. To realize simultaneous mitigation of the grid current and the supply voltage harmonics, this paper develops a

parallel-converter topology where the local nonlinear load is directly installed to the shunt filter capacitor of the first converter. The local load supply voltage quality is enhanced by the first interfacing converter through harmonic voltage control. The harmonic current produced by the interactions between the local nonlinear load and the first converter is then compensated by the second converter. To reduce the computational load of the dual-converter system, a modified hybrid voltage and current control method is proposed for parallel interfacing converters. With cooperative operation of two converters, the load current and supply voltage harmonic extraction and the phase-locked loops are not needed to realize this proposed comprehensive power quality control objective. Note that this paper focuses on the compensation of supply voltage and grid current harmonics. When there are significant disturbances in the main grids, such as sags/swells and interruptions, the shunt converter is less effective to compensate these grid issues.

2. REVIEW OF CONVENTIONAL APF AND DVR

Fig. 1(a) shows the topology and control strategy of an interfacing converter for compensating harmonic current from a local nonlinear load. First, the local load is connected to the output of the interfacing converter, and then, they are coupled to the main grid through the grid feeder. The parameters of the interfacing converter LCL filter and the grid feeder are listed as $z_1(s) = sL_1 + R_1$, $z_2(s) = sL_2 + R_2$, $z_3(s) = 1/(sC_f)$, and $z_g(s) = sL_g + R_g$, where L_1 , L_2 , R_1 , and R_2 are the inductance and resistance of the filter series chokes, C_f is

the capacitance of the shunt capacitor, and L_g and R_g are grid inductance and resistance.

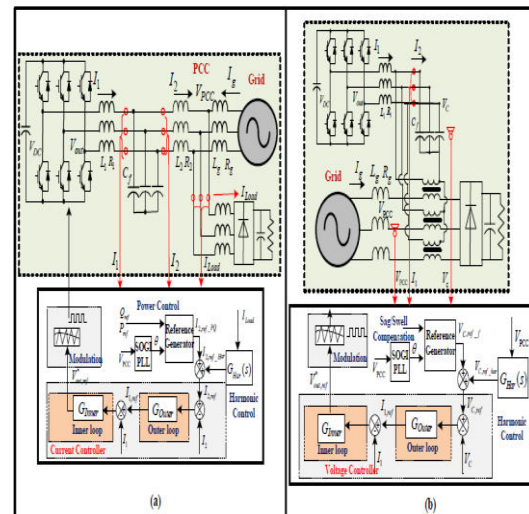

Fig. 1. Diagram of local harmonic compensation using interfacing converter

3. CONTROL STRATEGY FOR PROPOSED SYSTEM

To have simultaneous mitigation of the supply voltage and the grid current harmonics, a compensation method using coordinated control of two parallel interfacing converters is proposed in this section. The circuitry and control diagrams of the proposed system are shown in Fig. 2 and Fig. 3, respectively. First, a DG unit with two parallel interfacing converters sharing the same DC rail is connected to PCC. Each interfacing converter has an output LCL filter and the local nonlinear load is placed at the output filter capacitor of converter1. In this topology, the supply voltage to local nonlinear load is enhanced by controlling the harmonic component of interfacing converter1. Meanwhile, the grid current harmonic is mitigated via the power conditioning through interfacing converter2.

A. Control Strategy for Converter1

First, the line current $I_{2,1}$ of converter1 and the PCC voltage V_{PCC} as shown in Fig. 2 are measured to calculate the real and reactive output power of this converter

$$\begin{cases} P_{C1} = \frac{3\tau}{2(s+\tau)} (V_{PCC,\alpha} \cdot I_{2\alpha,C1} + V_{PCC,\beta} \cdot I_{2\beta,C1}) \\ Q_{C1} = \frac{3\tau}{2(s+\tau)} (V_{PCC,\beta} \cdot I_{2\alpha,C1} - V_{PCC,\alpha} \cdot I_{2\beta,C1}) \end{cases}$$

where P_{C1} and Q_{C1} are the output real and reactive power of converter1, $V_{PCC,\alpha}$ and $V_{PCC,\beta}$ are the PCC voltage in the two-axis stationary reference frame, and $I_{2\alpha,C1}$ and $I_{2\beta,C1}$ are the line current of converter1, and is the time constant of low pass filters.

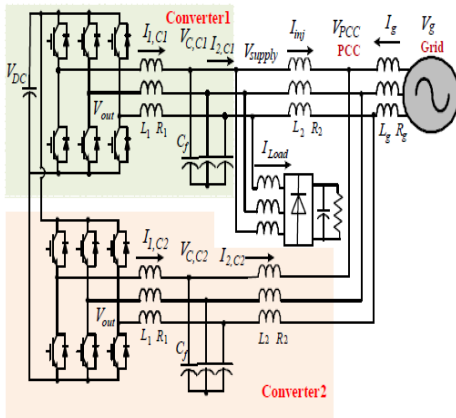

Fig. 2. Diagram of the proposed topology.

B. Control Strategy for Converter2

The control strategy of converter2 is similar to that of converter1, as also demonstrated in Fig. 3. However, both the fundamental and the harmonic converter currents are controlled. First, the regulators as shown in (6) to (8) are adopted to obtain the power control term reference $I^*_{2,PQ,C2}$ for converter2. Afterwards, another hybrid controller is used to realize the closed-loop line current control of converter2 as:

$$V^*_{out,C2} = H_{PQ}(s) \cdot (I^*_{2,PQ,C2} - I_{2,C2}) + H_{Har}(s) \cdot (I^*_{2,Har,C2} - I_{2,C2}) + H_{AD}(s) \cdot I_{1,C2}$$

where $V^*_{out,C2}$ is reference power voltage for converter2 PWM processing, $I^*_{2,PQ,C2}$ is the current reference for converter2 power control, $I^*_{2,Har,C2}$ is the current reference for converter2 line current harmonic control, $I_{1,C2}$ is the converter2 output current.

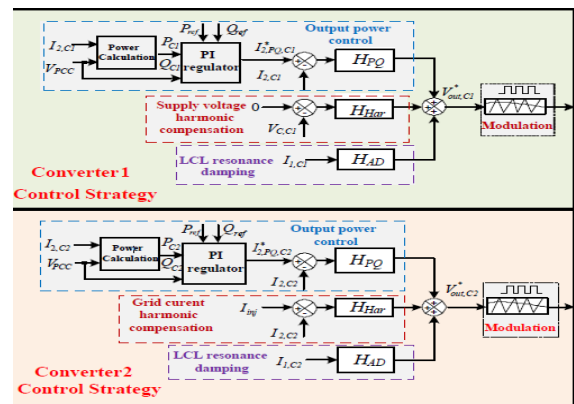

Fig. 3. Diagram of the proposed interfacing converter control strategies.

4.SIMULATION RESULTS

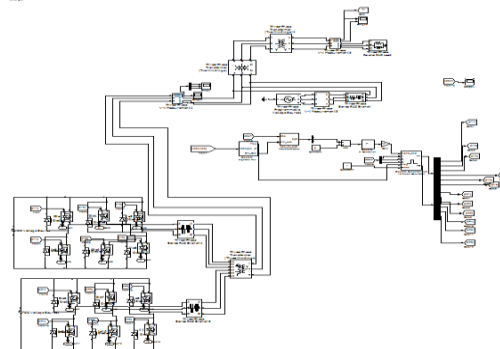

Fig 4. MATLAB/SIMULINK diagram of proposed system

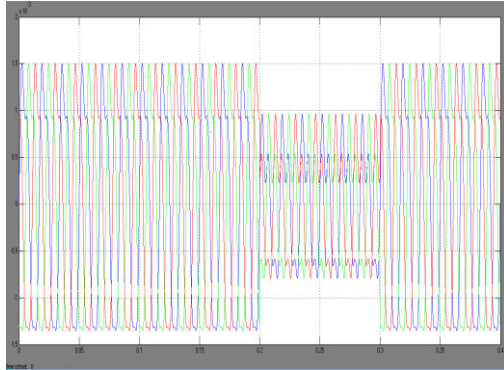

Fig 5. supply voltage

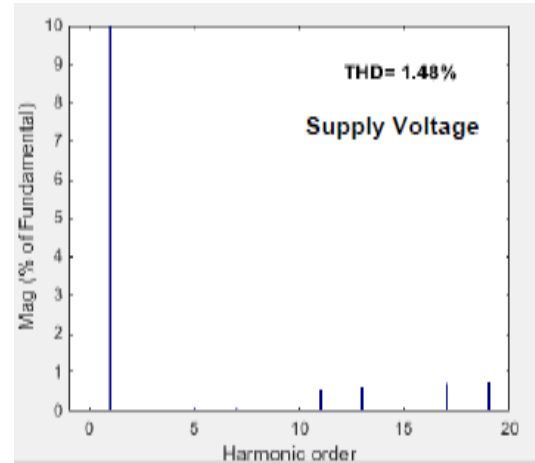

Fig 8. The harmonic spectrum of supply voltage

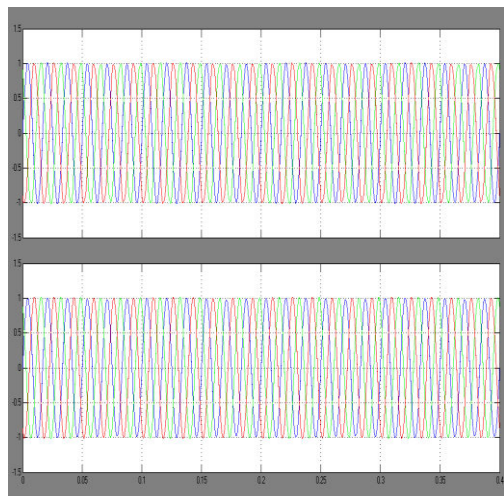

Fig 6. grid voltage and the grid current

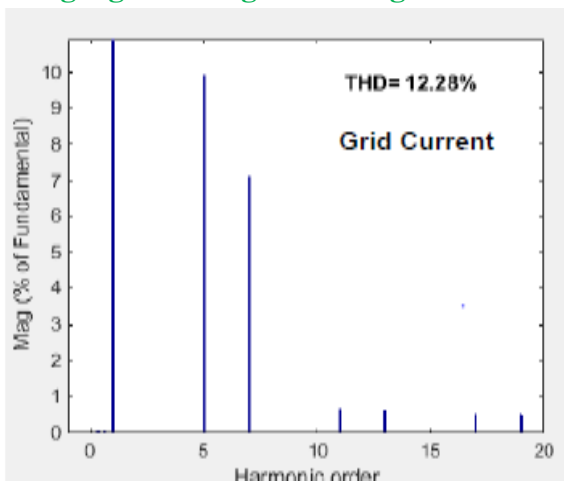

Fig.7. The harmonic spectrum of grid current

5. CONCLUSION

A single multi-functional interfacing converter is adopted to compensate the harmonic current from local nonlinear loads, the quality of supply voltage to local load can hardly be improved at the same time, particular when the main grid voltage is distorted. This paper discusses a novel coordinated voltage and current controller for dual-converter system in which the local load is directly connected to the shunt capacitor of the first converter. With the configuration, the quality of supply voltage can be enhanced via a direct closed-loop harmonic voltage control of filter capacitor voltage. At the same time, the harmonic current caused by the nonlinear load and the first converter is compensated by the second converter. Thus, the quality of the grid current and the supply voltage are both significantly improved. To reduce the computational load of DG interfacing converter, the coordinated voltage and current control without using load current/supply voltage harmonic extractions

REFERENCES

- [1] F. Blaabjerg, Z. Chen, and S. B. Kjaer, "Power electronics as efficient interface in dispersed power generation systems," *IEEE Trans. Power Electron.*, vol. 19, pp. 1184-1194, Sep. 2004.
- [2] A. Timbus, M. Liserre, R. Teodorescu, P. Rodriguez, and F. Blaabjerg, "Evaluation of current controllers for distributed power generation systems," *IEEE Trans. Power Electron.*, vol. 24, no. 3, pp. 654-664, Mar. 2009.
- [3] J. M. Guerrero, L. G. Vicuna, J. Matas, M. Castilla, and J. Miret, "A wireless controller to enhance dynamic performance of parallel inverters in distributed generation systems," *IEEE Trans. Power Electron.*, vol. 19, no. 4, pp. 1205-1213, Sep, 2004.
- [4] J. M. Guerrero, J. C. Vasquez, J. Matas, L.G. de Vicuna, and M. Castilla, "Hierarchical control of droop-controlled AC and DC microgrids - A general approach toward standardization," *IEEE Trans. Ind. Electron.*, vol. 55, no. 1, pp. 158 - 172, Jan. 2011.
- [5] J. He and Y. W. Li, "Analysis, design and implementation of virtual impedance for power electronics interfaced distributed generation," *IEEE Trans. Ind. Applicat.*, vol. 47, no. 6, pp. 2525-2038, Nov/Dec. 2011.
- [6] Q. Zhang, "Robust droop controller for accurate proportional load sharing among inverters operated in parallel," *IEEE Trans. Ind. Electron.*, vol. 60, no. 4, pp. 1281-1290, Apr. 2013.
- [7] W. Issa, M. Abusara, and S. Sharkh, "Control of transient power during unintentional islanding of microgrids," *IEEE Trans. Power Electron.*, online early access.
- [8] C.-L. Chen, Y. Wang, J.-S. Lai, Y.-S. Lee, D. Martin, "Design of parallel inverters for smooth mode transfer microgrid applications," *IEEE Trans. Power. Electron.*, vol. 25, no. 1, pp. 6-15, Jan. 2010.
- [9] N. Pogaku and T.C. Green, "Harmonic mitigation throughout a distribution system: a distributed-generator-based solution," *IEE Proc. Gener. Transm. Distrib.*, vol.153, no.3, pp. 350- 358, May. 2006.
- [10] C. J. Gajanayake, D. M. Vilathgamuwa, P. C. Loh, R. Teodorescu, and F. Blaabjerg, "Z-source-inverter-based flexible distributed generation system solution for grid power quality improvement," *IEEE Trans. Energy Conversion*, vol.24, pp.695-704, Sep. 2009.