



International Journal for Innovative Engineering and Management Research

A Peer Reviewed Open Access International Journal

www.ijiemr.org

COPY RIGHT

2017 IJIEMR. Personal use of this material is permitted. Permission from IJIEMR must be obtained for all other uses, in any current or future media, including reprinting/republishing this material for advertising or promotional purposes, creating new collective works, for resale or redistribution to servers or lists, or reuse of any copyrighted component of this work in other works. No Reprint should be done to this paper, all copy right is authenticated to Paper Authors

IJIEMR Transactions, online available on 6th July 2017. Link :

<http://www.ijiemr.org/downloads.php?vol=Volume-6&issue=ISSUE-5>

Title: Enhancement of Power Quality of Wind Farms With Fuzzy Logic Controller Using An Inductive Filtering Method.

Volume 06, Issue 05, Page No: 1544 - 1551.

Paper Authors

* **YELLELA BHARGAVA RAMU, S.RAVINDRA.**

* Dept of EEE, QIS College of Engineering & Technology.



USE THIS BARCODE TO ACCESS YOUR ONLINE PAPER

To Secure Your Paper As Per **UGC Guidelines** We Are Providing A Electronic Bar Code

ENHANCEMENT OF POWER QUALITY OF WIND FARMS WITH FUZZY LOGIC CONTROLLER USING AN INDUCTIVE FILTERING METHOD

***YELLELA BHARGAVA RAMU, **S.RAVINDRA**

*PG Scholar, Dept of EEE, QIS College of Engineering & Technology (autonomous), Ongole, Prakasam (Dt); Andhrapradesh, India.

**Professor, Dept of EEE, QIS College of Engineering & Technology (autonomous), Ongole, Prakasam (Dt); Andhrapradesh, India.

y.bhargava204@gmail.com sanguravindra11@gmail.com

ABSTRACT:

Traditionally, passive filters have been used to eliminate current harmonics of the supply network. However, these devices suffer from resonance. Recently, thyristor-inductive filters (TIFs), which contain several groups of passive filters, have been used to compensate reactive power. NONLINEAR loads cause significant harmonic currents with poor input power factor (PF), which create serious problems at the power supply system. The compensation amount of TIFs can be adjusted with the variation of load power. However, the parallel and the series resonance could occur between TIF and grid impedance a STATCOM model is also developed. Simulation studies are carried out in the Digsilent/Power factory to illustrate the performance of the new grid connected wind power system. The results indicate that the new approach can not only enhance the low-voltage ride-through capability of wind turbines, but also significantly prevent harmonic components flowing into the primary (grid) winding of the new grid connected transformer. The proposed concept can be implemented to Fuzzy Based Dynamic Voltage of Wind farms of IFM BY using Matlab/Simulink software.

Keywords: Inductive filtering method; STATCOM; grid connected system; wind farm, Induction motor.

I. INTRODUCTION

To have sustainable growth and social progress, it is necessary to meet the energy need by utilizing the renewable energy resources like wind, biomass, hydro, co-generation, etc. In sustainable energy system, energy conservation and the use of renewable source are the key paradigm.

The need to integrate the renewable energy like wind energy into power system is to make it possible to minimize the environmental impact on conventional plant [1].

The integration of wind energy into existing power system presents technical challenges and that requires consideration of voltage regulation, stability, power quality problems.

The power quality is an essential customer-focused measure and is greatly affected by the operation of a distribution and transmission network. The issue of power quality is of great importance to the wind turbine [2].

There has been an extensive growth and quick development in the exploitation of wind energy in recent years.

The individual units can be of large capacity up to 2 MW, feeding into distribution network, particularly with customers connected in close proximity [3]. Today, more than 28000 wind generating turbines are successfully operating all over the world. In the fixed-speed wind turbine operation, all the fluctuation in the wind speed are transmitted as fluctuations in the mechanical torque, electrical power on the grid

and leads to large voltage fluctuations. The power quality issues can be viewed with respect to the wind generation, transmission and distribution network, such as voltage sag, swells, flickers, harmonics etc [4-5].

However the wind generator introduces disturbances into the distribution network. One of the simple methods of running a wind generating system is to use the induction generator connected directly to the grid system. The induction generator has inherent advantages of cost effectiveness and robustness.

However; induction generators require reactive power for magnetization. When the generated active power of an induction generator is varied due to wind, absorbed reactive power and terminal voltage of an induction generator can be significantly affected [6-7].

STATCOM can be effectively utilized to regulate voltage for one large rating motor or for a series of small induction motors starting simultaneously. Thyristor based svcloads draw large starting currents (5- 6times) of the full rated current and may affect working of sensitive loads.

Thyristor based systems were initially proposed for reactive power compensation and were used for voltage flicker reduction due to arc furnace loads. However, due to disadvantages of passive devices such as large size, fixed compensation, possibility of resonance etc., the use of new compensators such as STATCOM is growing to solve power quality problems.

The use of STATCOM for solving power quality problems due to voltage sags, flickers, swell etc has been suggested. The purpose of STATCOM is to provide efficient voltage regulation during short duration of thyristor based svc starting and thus prevent large voltage dips [8-9].

II. MAIN CIRCUIT TOPOLOGY OF THE NEW GRID CONNECTED WIND POWER SYSTEM

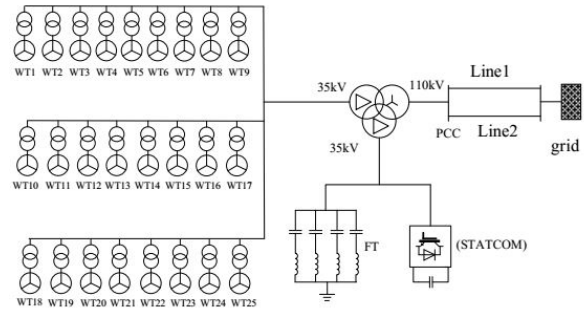

Fig.1. Main circuit topology of the grid connected wind power system.

Fig.1 shows the main circuit topology of the grid connected wind power system. From this, it can be seen that it is a 50 MW wind farm composed of 25 double-fed induction generators (DFIGs), and each DFIG has a rating of 2 MW. Each wind turbine is connected to the wind farm internal 35 kV cable network via a 2.2 MVA, 0.69/35 kV transformer. The wind farm is connected to the power grid by means of a new grid-connected transformer, which has the grid winding, the secondary winding and the filtering winding, respectively. The FT branches and STATCOM are connected to the filtering winding of the new grid-connected transformer. The point of common coupling (PCC) voltage should be regulated at the 110 kV.

III. HARMONIC MODEL AND EQUIVALENT CIRCUIT MODEL

To study the filtering mechanism of the inductive method, the single-phase equivalent circuit model of the new grid connected transformer is established as shown in Fig.2, in which, the VSC-based wind turbine generators can be regarded as the voltage source. The harmonic current in the grid winding, secondary winding and filtering winding are the I_{1n} , I_{2n} and I_{3n} respectively.

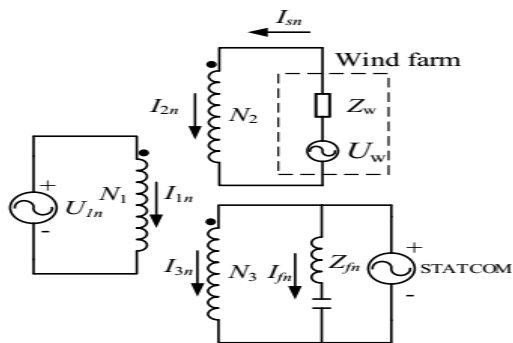

Fig.2. the single-phase equivalent-circuit model of the new grid connected transformer with FT branches.

According to Fig.2, the equations of the harmonic current and voltage can be obtained:

$$\begin{cases} U_{3n} = I_{fn} Z_{fn} \\ I_{3n} = -I_{fn} \\ I_{2n} = I_{sn} \end{cases} \quad (1)$$

Moreover, the magnetic-potential balance equation can be expressed as follows:

$$N_1 I_{1n} + N_2 I_{2n} + N_3 I_{3n} = 0 \quad (2)$$

Where N_1 , N_2 , N_3 are the numbers of turns of the grid winding, the secondary winding and the filtering winding respectively. Then, according to the theory of the multi-winding transformer, the voltage transfer equations can be obtained:

$$\begin{cases} U_{2n} - \frac{N_2}{N_1} U_{1n} = -\frac{N_1}{N_1} Z_{21n} I_{1n} - \frac{N_3}{N_2} Z_{2n} I_{3n} \\ U_{2n} - \frac{N_2}{N_3} U_{3n} = -\frac{N_3}{N_2} Z_{23n} I_{3n} - \frac{N_1}{N_2} Z_{2n} I_{1n} \end{cases} \quad (3)$$

Where Z_{21n} is the short-circuit impedance between the secondary winding and the primary winding; Z_{23n} is the short-circuit impedance between the secondary winding and the filtering winding. They can be obtained by the transformer short-circuit test. Z_{2n} is the equivalent impedance of the secondary winding and can be calculated by the short-circuit impedance, as shown in follows.

$$Z_{2n} = \frac{1}{2} \left(Z_{21n} + Z_{23n} - \frac{N_2^2}{N_3^2} Z_{32n} \right) \quad (4)$$

There are no harmonic current in the primary winding of the new grid connected transformer, thus we can obtain $U_{1n} \approx 0$. According to the mathematic model, the current in the primary winding of the new grid connected transformer can be expressed as follows:

$$I_{1n} = -\frac{N_1 N_2 (Z_{3n} + Z_{fn})}{N_1^2 (Z_{3n} + Z_{fn}) + N_3^2 Z_{1n}} I_{sn} \quad (5)$$

From equation (5), it can be seen that as long as the Z_{3n} and Z_{fn} approximately equal or equal zero, the condition of the inductive filtering method can be satisfied. Thereby, there is no or few harmonic current in the grid (primary) winding, which reveals the filtering mechanism of the new grid connected transformer and related FT branches. Moreover, the special impedance design of the new grid connected transformer can make the equivalent impedance of the filtering winding (Z_{3n}) approximately equal zero.

IV. REACTIVE POWER COMPENSATION CHARACTERISTIC

A. Phasor Analysis

In the new grid connected wind power system, FT branches and STATCOM can support voltage stability by compensating reactive power. According to the current distribution in the new grid connected transformer, as shown in Fig.3, we can obtain the phasor diagram of the secondary winding's voltage and current of the new grid connected transformer, as shown in Fig.4.

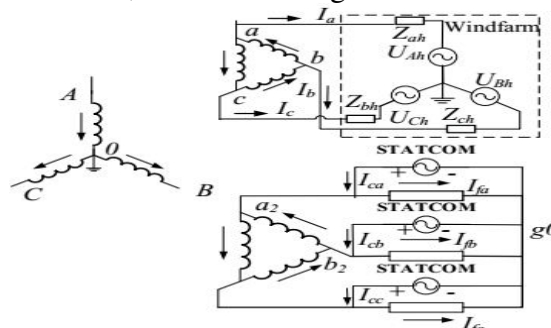

Fig. 3. The current distribution of the new grid connected transformer.

Taking the A-phase winding in Fig.4 as an example, assume the secondary winding current I_a lags the phase of the secondary winding voltage U_a by δ .

Since the impedance of the FT branches is capacitive for the fundamental, when we carry out the FT branches and STATCOM, the phase current of the FT branches will lead 90° to the secondary winding voltage U_a .

In addition, the currents I_{ca} that the STATCOM injected lags the phase of the secondary winding voltage U_a by 90° , also. Thus, we can obtain that the angle of the load-side I'_a (with the inductive filtering method and STATCOM) lags the secondary winding voltage U_a is smaller than δ . Hence, it is known that the FT branches and STATCOM have reactive power compensation ability in the secondary winding, which means the FT branches and STATCOM can improve the power quality of the wind farms.

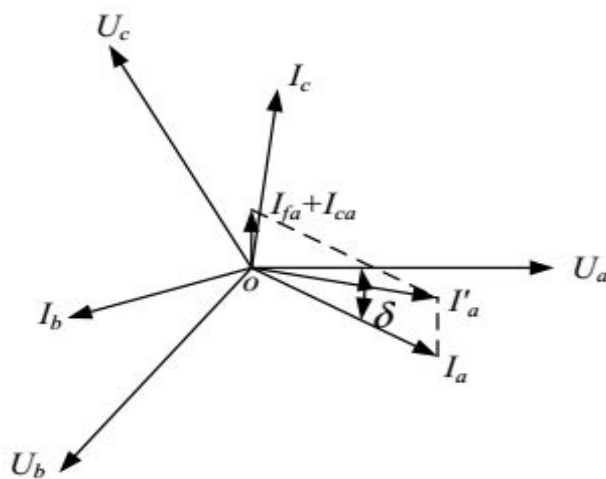

Fig.4 Phasor diagram of the voltage and current of the secondary winding.

B. Control Scheme of STATCOM

The STATCOM and its controller are shown in Fig.5. It connects the filtering winding and can improve transient stability of power grid (V_{ac}).

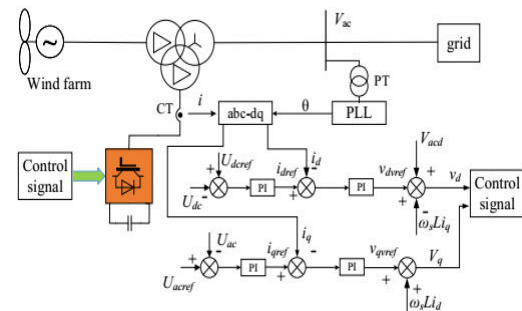

Fig.5. Schematic diagram of STATCOM controller.

The STATCOM regulate voltage of the grid winding of the new grid connected transformer by controlling the reactive power injected into or absorbed from the power grid. In the Fig.5, an outer regulation loop contains an ac voltage regulator and a dc voltage regulator, while an inner regulation loop contains a current regulator. The control signal of STATCOM (e.g. V_d , V_q) can be obtained by the regulator loop and they are usually used by the PWM module to generate the pulse signals to drive IGBT of the STATCOM.

The objective of the STATCOM is primarily to keep the ac voltage constant. During the normal conditions, the grid voltage is stability and the reactive power flow from or to STATCOM is approximately zero. When the grid is under fault conditions, The STATCOM will inject amount of reactive power for the system instantly. Hence, this voltage control strategy reacts immediately to a sudden voltage variation and is well-suitable for fault condition operation in the grid connected wind power system.

V THYRISTOR-CONTROLLED WITH FUZZY LOGIC CONTROLLER

Power system transient stability is one of the most challenging technical areas in electric power industry. Thyristor-controlled series compensation (TCSC) is expected to improve transient stability and damp power oscillations. TCSC control in power system transients is a nonlinear control problem. This paper presents

a T-S-model-based fuzzy control scheme and a systematic design method for the TCSC fuzzy controller. The nonlinear power system containing TCSC is modeled as a fuzzy “blending” of a set of locally linearized models. A linear optimal control is designed for each local linear model. Different control requirements at different stages during power system transients can be considered in deriving the linear control rules. The resulting fuzzy controller is then a fuzzy “blending” of these linear controllers. Quadratic stability of the overall nonlinear controlled system can be checked and ensured using control theory. Digital simulation with NETOMAC software has verified that the fuzzy control scheme can improve power system transient stability and damp power swings very quickly. L. A. Zadeh presented the first paper on fuzzy set theory in 1965. Since then, a new language was developed to describe the fuzzy properties of reality, which are very difficult and sometime even impossible to be described using conventional methods. Fuzzy set theory has been widely used in the control area with some application to dc-to-dc converter system. A simple fuzzy logic control is built up by a group of rules based on the human knowledge of system behavior. Matlab/Simulink simulation model is built to study the dynamic behavior of dc-to-dc converter and performance of proposed controllers. Furthermore, design of fuzzy logic controller can provide desirable both small signal and large signal dynamic performance at same time, which is not possible with linear control technique. Thus, fuzzy logic controller has been potential ability to improve the robustness of dc-to-dc converters. The basic scheme of a fuzzy logic controller is shown in Fig 5 and consists of four principal components such as: a fuzzification interface, which converts input data into suitable linguistic values; a knowledge base, which consists of a data base with the necessary linguistic definitions and the control rule set; a decision-making logic which,

simulating a human decision process, infer the fuzzy control action from the knowledge of the control rules and linguistic variable definitions; a de-fuzzification interface which yields non fuzzy control action from an inferred fuzzy control action [10].

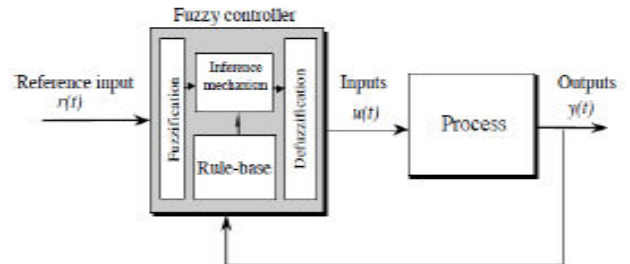

Fig.6. General Structure of the fuzzy logic controller on closed-loop system

The fuzzy control systems are based on expert knowledge that converts the human linguistic concepts into an automatic control strategy without any complicated mathematical model [10]. Simulation is performed in buck converter to verify the proposed fuzzy logic controllers.

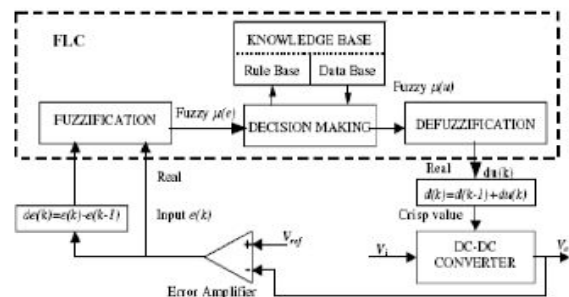

Fig.7 Block diagram of the Fuzzy Logic Controller (FLC) for dc-dc converters

Fuzzy Logic Membership Functions:

The dc-dc converter is a nonlinear function of the duty cycle because of the small signal model and its control method was applied to the control of boost converters. Fuzzy controllers do not require an exact mathematical model. Instead, they are designed based on general knowledge of the plant. Fuzzy controllers are designed to adapt to varying operating points. Fuzzy Logic Controller is

designed to control the output of boost dc-dc converter using Mamdani style fuzzy inference system. Two input variables, error (e) and change of error (de) are used in this fuzzy logic system. The single output variable (u) is duty cycle of PWM output.

Big and its parameter. These fuzzy control rules for error and change of error can be referred in the table that is shown in Table II as per below:

Table II

Table rules for error and change of error

(de) \ (e)	NB	NS	ZO	PS	PB
NB	NB	NB	NB	NS	ZO
NS	NB	NB	NS	ZO	PS
ZO	NB	NS	ZO	PS	PB
PS	NS	ZO	PS	PB	PB
PB	ZO	PS	PB	PB	PB

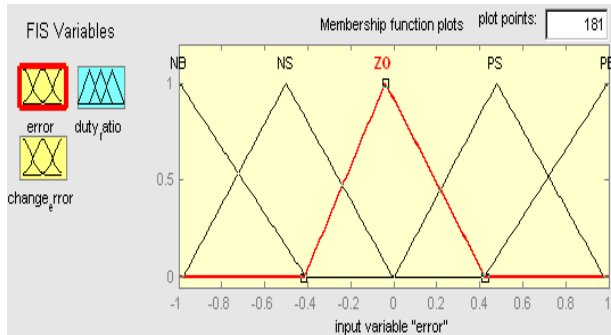

The Membership Function plots of error

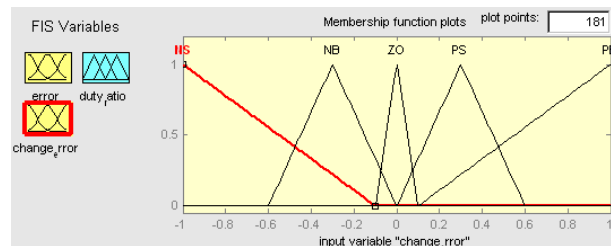

The Membership Function plots of change error

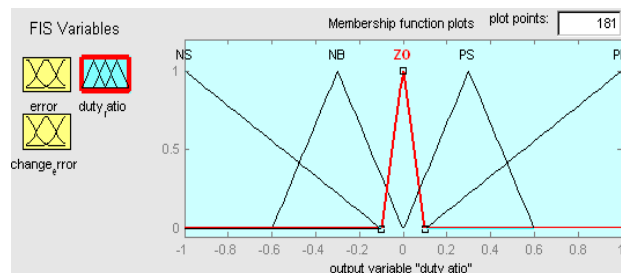

Fig.8the Membership Function plots of duty ratio

Fuzzy Logic Rules:

The objective of this dissertation is to control the output voltage of the boost converter. The error and change of error of the output voltage will be the inputs of fuzzy logic controller. These 2 inputs are divided into five groups; NB: Negative Big, NS: Negative Small, ZO: Zero Area, PS: Positive small and PB: Positive

VI.MATLAB/SIMULATION RESULTS

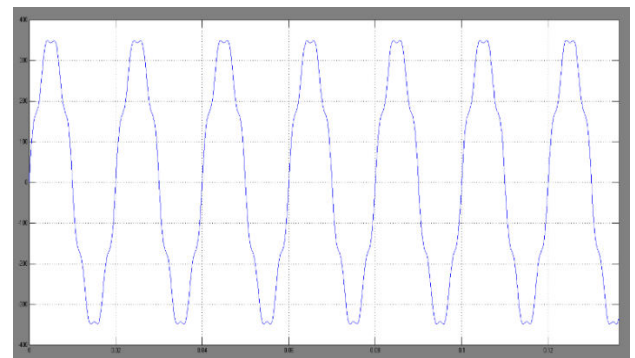

Fig.9. Current in the grid winding of the new grid-connected transformer without inductive filtering method.

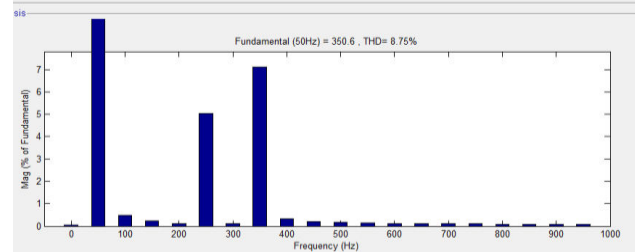
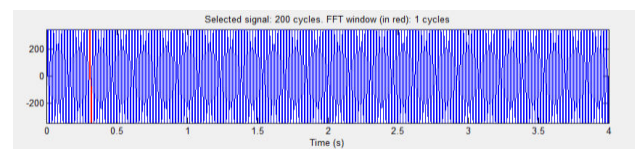

Fig.10. FFT results on the current waveform in the without filter.

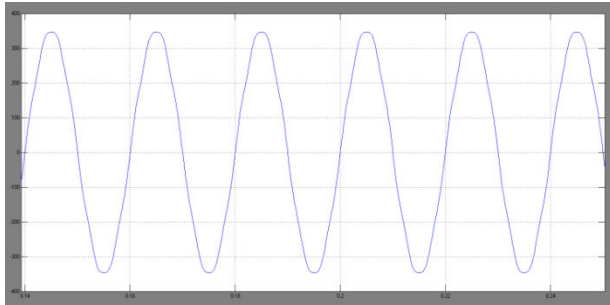

Fig.11. Current in the grid winding of the new grid-connected transformer with inductive filtering method.

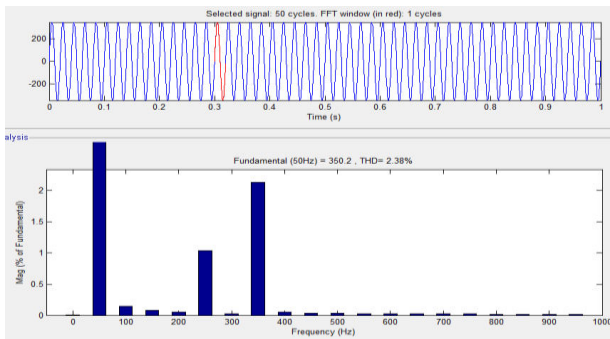

Fig.12. FFT results on the current waveform in the with filter.

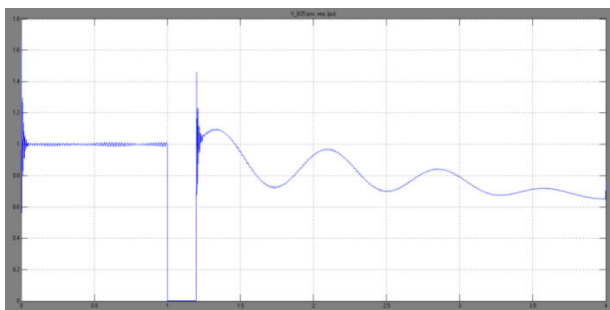

Fig.13. Magnitudes of the voltage at the PCC without STATCOM.

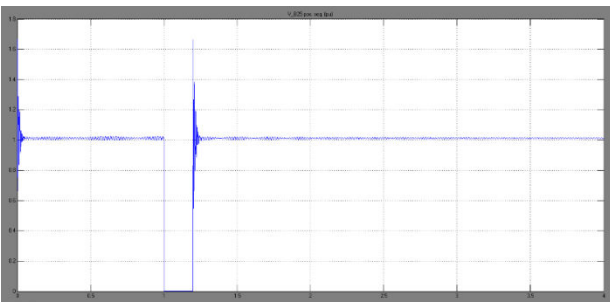

Fig.14. Magnitudes of the voltage at the PCC with STATCOM.

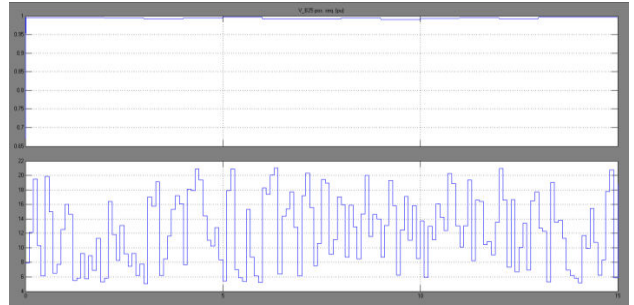

Fig.15. Wind speed vs. time for the wind farm.

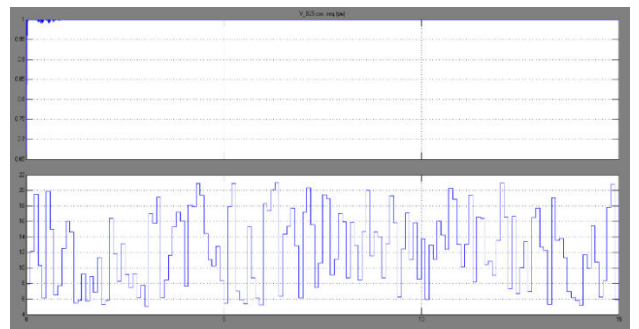

Fig.16. Magnitudes of the voltage at the PCC.

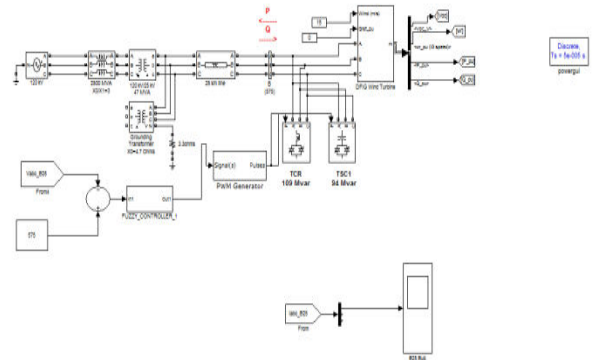

Fig.17. Matlab/Simulation model of Main circuit topology with thyristor fuzzy logic controller

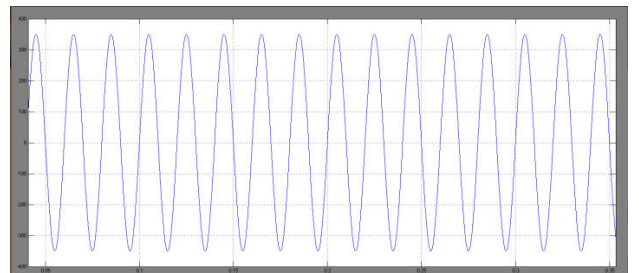

Fig.18 Simulation wave form of three phase line current with Thyristor based fuzzy logic controller

VII. CONCLUSIONS

A model of three phase source wind frame thyristor based fuzzy logic controller has been developed using Simulink tool of standard MATLAB software. To propose with thyristor fuzzy logic controller of voltage dip with and without STATCOM controller. This dip is very large and it may affect the functioning of other sensitive equipment connected at PCC Model of STATCOM system applied in shunt configuration has been developed. The STATCOM control utilizes two PI controllers for regulating DC link voltage and also the ac terminal voltage at PCC. The simulation results indicate that the new approach not only can significantly improve the filtering performance, but also effectively reduced the level of voltage fluctuation when the wind speed varies in a large range. Moreover, the new approach can successfully reestablished the PCC voltage in case of the grid fault, and therefore, enhanced the low-voltage ride through capability of the wind farm.

REFERENCES

- [1] D. Dhungana and R. Karki, "Data constrained adequacy assessment for wind resource planning," *IEEE Trans. Sustain. Energy*, Vol 6, no. 1, pp: 219-227, Jan. 2015.
- [2] A. Haque, M. Nehrir and P. Mandal, "A hybrid intelligent model for deterministic and quantile regression approach for probability wind power forecasting" *IEEE Trans. Power Syst.*, Vol 29, no. 4, pp: 1663-1672, Jul. 2014.
- [3] M. Zugno, P. Pinson and H. Madsen, "Impact of wind power generation on european cross-border power flows," *IEEE Trans. Power Syst.*, Vol 28, no. 4, pp: 3566-3575, Nov. 2013.
- [4] L. Shun, Q. Hu and W. Lee, "A survey of harmonic emissions of a commercially operated wind farm," *IEEE Trans. Ind. Appl.*, Vol 48, no. 3, pp: 1115-1123, May. 2012.
- [5] C. Li, P. Zhan, J. Wen, M. Yao, N. Li and W. Lee "Offshore wind farm integration and frequency support control utilizing hybrid multi terminal HVDC transmission," *IEEE Trans. Ind. Appl.*, Vol 50, no. 4, pp: 2788-2797, Jul/Aug. 2014.
- [6] S. W. Mohod and M. Aware "A STATCOM-control scheme for grid connected wind energy system for power quality improvement," *IEEE Trans. Syst. Journal.*, Vol 4, no. 3, pp: 346-352, Sep. 2010.
- [7] W. Li and D. Truong, "Dynamic stability improvement of four parallel-operated PMSG-based offshore wind turbine generators fed to a power system using a STATCOM," *IEEE Trans. Power. Del.*, Vol 28, no. 1, pp: 111-118, Jun. 2013.
- [8] K. Hasan, K. Rauma, A. Luna, J. Candela and P. Rodríguez, "Harmonic compensation analysis in offshore wind power plant using hybrid filters," *IEEE Trans. Ind. Appl.*, Vol 50, no. 3, pp: 2050-2060, May/Jun. 2014.
- [9] Y. Li, L. Luo, C. Rehtanz, D. Yang, S. Rüberg and F. Liu, "Harmonic transfer characteristics of a new HVDC system based on an inductive filtering method," *IEEE Trans. Power. Elect.*, Vol 27, no. 5, pp: 2273-2282, May. 2012.