



International Journal for Innovative Engineering and Management Research

A Peer Reviewed Open Access International Journal

www.ijiemr.org

COPY RIGHT



ELSEVIER
SSRN

2022 IJIEMR. Personal use of this material is permitted. Permission from IJIEMR must be obtained for all other uses, in any current or future media, including reprinting/republishing this material for advertising or promotional purposes, creating new collective works, for resale or redistribution to servers or lists, or reuse of any copyrighted component of this work in other works. No Reprint should be done to this paper, all copy right is authenticated to Paper Authors

IJIEMR Transactions, online available on 12th Dec 2022. Link

[:http://www.ijiemr.org/downloads.php?vol=Volume-11&issue=Issue 12](http://www.ijiemr.org/downloads.php?vol=Volume-11&issue=Issue 12)

DOI: 10.48047/IJIEMR/V11/ISSUE 12/64

Title **TOXIC GAS DETECTION AND MONITORING USING IOT**

Volume 11, ISSUE 12, Pages: 512-518

Paper Authors

K. Kalpana, B. Deekshitha, B. Ramadevi, B. Bindhu Sai Nithin, P. Ganesh



USE THIS BARCODE TO ACCESS YOUR ONLINE PAPER

To Secure Your Paper As Per **UGC Guidelines** We Are Providing A Electronic Bar Code

TOXIC GAS DETECTION AND MONITORING USING IOT

K. Kalpana¹, B. Deekshitha², B. Ramadevi², B. Bindhu Sai Nithin², P. Ganesh²

^{1,2}Department of Electronics and Communication Engineering

^{1,2}Malla Reddy Engineering College and Management Sciences, Medchal, Telangana

ABSTRACT

The home security sensor monitoring is very important for security. Now a day's technology enhances the security system to next level. In the proposed article we monitor the home security parameters and alerting system to prevent the over damage in case of emergency. Proposed system uses intruder theft detection sensor, smoke, Toxic gas, fire sensors for security monitoring and data will process by Arduino Microcontroller. All the sensor data will post into GSM SMS and LCD which inbuilt in Arduino. Buzzer module used to alert at home for security and alert through GSM SMS. This proposed article will enhance the people security and necked eye monitoring about the emergency in home.

Keywords: Home security, Gas detection, GSM module.

1. INTRODUCTION

In this 21st century, Home/domestic monitoring holds great importance and have uses in several areas ranging from keeping track of agricultural field Home/domestic conditions to Home/domestic conditions monitoring. Home/domestic monitoring would help in keeping track of different climatic behaviors including temperature, humidity and light intensity. Home/domestic Monitoring System can be either wired or wireless one. In case of wireless communication, the connectivity will be more convenient and user friendly and Home/domestic monitoring would not require physical presence of the person at the location. Wireless communication is the transfer of information over a distance without the use of wires. The objective of this project is to design a wireless Home/domestic monitoring system in which a microcontroller is interfaced with sensors, GSM module to transmit sensed data wirelessly. Analog data from LM35

is to be fetched and fed to one of the ADC channels of Microcontroller. Display the temperature on GSM screen which is pre-processed and calculated by ATmega32.

An embedded system is a combination of software and hardware to perform a dedicated task. Some of the main devices used in embedded products are Microprocessors and Microcontrollers. Microprocessors are commonly referred to as general purpose processors as they simply accept the inputs, process it and give the output. In contrast, a microcontroller not only accepts the data as inputs but also manipulates it, interfaces the data with various devices, controls the data and thus finally gives the result. The project "Home/domestic **Reporting using GSM Display**" using ARDUINO microcontroller is an exclusive project which is used to display Home/domestic parameters like Temperature and Humidity on an GSM Display. The thesis explains the implementation of "Home/domestic

Reporting using GSM Display” using ARDUINO microcontroller.

A Home/domestic sensor is where plants such as flowers and vegetables are grown. Home/domestics warm up during the day when sun-rays penetrate through it, which heats the plant, soil and structure. Green houses help to protect crops from many diseases, particularly those that are soil borne and splash onto plants in the rain. Home/domestic effect is a natural phenomenon and beneficial to human being. Numerous farmers fail to get good profits from the Home/domestic crops for the reason that they can't manage two essential factors, which determine plant growth as well as productivity. Home/domestic sensor temperature should not go below a certain degree, High humidity can result to crop transpiration, condensation of water vapour on various Home/domestic surfaces, and water evaporation from the humid soil. To overcome such challenges, this Home/domestic monitoring and control system comes to rescue. This project demonstrates the design and implementation of a various sensors for Home/domestic environment monitoring and controlling. This Home/domestic control system is powered by Atmega328 microcontroller it consists of temperature sensor, light sensor, soil moisture sensor, LDR sensor, LCD display module, 12v DC fan, Bulb and pump. Temperature sensor, senses the level of temperature., if it goes high DC fans gets on and when the temperature goes low the fan gets off. Soil moisture sensor, senses the water level as the level decreases the pumps gets on. In the absence of light, the LDR sensor

senses and the bulb starts glowing. By this way it will become easy to monitor and control the system.

Conventional Home/domestics need regulated climate conditions to grow plants in there. Without an automatic control system, it is quite impossible to maintain the accurate climate conditions inside the green houses. This paper proposes such an automatic system for Home/domestics to control its' internal environment, to store each climate properties in a database for future analysis and to ensure remote monitoring to those data. Internet of Things (GSM) is used for remote monitoring and analysis of data. Also, an android application is developed to display those data in a short range through Bluetooth technology. The system controls the temperature, humidity, light and soil moisture level by sensing the values from sensors and controlling heaters/coolers, sprayers, bulbs and water pumps accordingly.

2. LITERATURE SURVEY

The Home/domestic manufacturing is the quickest developing part of the world. This manufacturing isolates the yield from nature, subsequently giving some method for protection from the immediate impact of the outside climate conditions [1]. This empowers the manufacture of harvests which generally couldn't be created at that particular area. The Home/domestic walled in area empowers the control of the harvest condition. This advantage enables the farmer to enhance the development in a way the plants require. It prompts higher harvest yield, extended manufacturing period, higher quality, and less utilization of defensive synthetic substances. The

introduced cost per unit region in Home/domestic vegetation is significantly higher than that in open-field farming. In modest macroclimate zones, energy is required, while in dry zones, the cooling and accessibility of water is of primary concern. The utilization of materials and energy and in addition crop yield and quality can be impacted by working the flexible segments of the Home/domestic, for example, warming and cooling inputs, window opening, dribble water system, showing and CO₂ dose [3], [4]. Consequently, it can be anticipated that the manner in which these controls are worked impacts the final financial result. To absolutely take advantage of the stronger probabilities for harvest and asset administration in a Home/domestic, it is vital to know the control factors with a remote detecting framework utilizing the GSM. In fact, remote correspondence structures are an essential issue of the arrangement of modernization and innovation exchange, because of the expanding advancement of portable media communications [6]. Internet of Things (GSM) can be expressed as the architecture of physical things implanted with electronic circuits, sensors and programming along with an associative system that empowers these things to trade information from each other. GSM is the combination of the computerized and physical world. In a universe of GSM, a huge number of things or apparatuses will be interconnected and interestingly recognized on the Internet [2]. The Internet of Things enables the system to detect and control other devices remotely transversely over existing system foundation, making good interrelation between the physical

world and different computer-based frameworks and creating chances for enhanced effectiveness, financial advantage and precision. In near future, GSM is relied upon to give numerous more administrations like propelled availability of physical questions over a wide system and furthermore numerous applications [5]. It is apparent to think that in utilizing these administrations given by this innovation, it is conceivable to control and screen frameworks from a separation utilizing the GSM arrange. Mobile internet is coordinated applications as valuable as home automation, Home/domestic purposes for managing and far off monitoring of complicated systems however also in safety systems and ensure property and individuals. Most physical factors important in a Home/domestic can be estimated via automatic sensors [5]. This holds for temperature, light, soil dampness, and relative humidity. Precipitation can additionally be detected, even though it is truly much less common. All the specified physical factors are inspected and put away electronically at normal interims when something is evolving. Inclusive, the estimations give a significant decent info yield snap of the physical phase of the Home/domestic harvest structure. We suggest a commitment to the improvement of Home/domestic monitoring. Recently, the developments in the field of the GSM technology have led to renewed interest in developing the Home/domestic technology system. The pleasant was grumblings from a few things, for example, keep track the irrigation system process and doing it manually. Also, the plants may suffer from bad effects of awful conditions like

temperature and light. An Intelligent Agriculture Home/domestic Environment Monitoring System Based on GSM Technology [7] to those Mediterranean nations, for example, Italy, Turkey, Greece Also Spain the place mechanical transformation level of Home/domestic development may be low. The task means should increment the innovations of Home/domestic societies toward the formation about a coordinated circuit organize for sensors and automation technologies, controlled by an ICT (Information and Communication Technologies) approach, for the agronomic development of horticultural crops. The data identified with the Home/domestic environment and yield status and control the system automatically in view of the gathered data. By throtily observing periodic conditions, this study has the reason for securing the connection between sensors signals and reference estimations. To monitor the environment inside Home/domestic different parameters have been considered such as light, temperature, humidity, soil moisture etc. using different sensors like DHT22 temperature and humidity Sensor, LDR, grove-moisture sensor etc. which will be interfaced with the microcontroller. With the development of agriculture needs, the Home/domestic has huge development prospects [9], it can bring huge economic benefits to agriculture. ZigBee technology to carry out remote wireless monitoring of temperature and humidity signals in vegetable Home/domestics. It sends data signal from the temperature and humidity sensor of each node gaining to the main control system through the wireless communication way. According to the

monitoring and management needs of the modern Home/domestic design and implementation of modern Home/domestic remote monitoring system based on the Web. Ajax technology is applied to the development of web applications, which improves the response and interactivity of the system. Also presents agreeable correspondence based remote sensor organize for checking Home/domestic related parameters, for example, Temperature, Humidity, and Carbon-di-oxide. This product utilizes an Android cell phone, associated utilizing Wi-Fi to a local server which interfaces by means of serial correspondence to a microcontroller and mugginess sensor. In designing this device, there is a restriction on issues, to perceive how far this framework can do its errands. ARM-based remote monitoring and Control System for environmental parameters in the Home/domestic. It overcomes the disadvantages of wired and wireless constraints such as complicated wiring, difficult maintenance, and distance, to monitor and control the applications. All the works described above, and any other papers didn't show GSM based Home/domestic automation system. The major objective of this paper is to develop a practical smart Home/domestic with intelligent control systems to obtain suitable circumstances. The proposed system can monitor and control the Home/domestic from any place in the world. Fig 1 depicts the block diagram of the entire system. The overall designed system could be divided into three important parts: hardware, software, and GSM structure.

3. PROPOSED SYSTEM

In this proposed system a low-cost, easily installable and scalable Home/domestic sensor monitoring system is developed with GSM technology after researching lots of recently published papers and considering the reality of it. In this section, the experiment block diagrams with setup are illustrated.

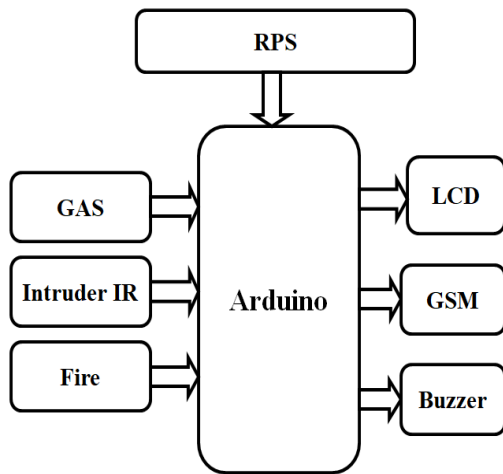

Fig. 1: Block diagram of proposed system.

The proposed system needs to collect temperature, gas, and fire intensity of particulate inputs from different sensors used to detect Home/domestic sensor monitoring. The monitoring data inputs are collected by the Arduino microprocessor control unit, and then Arduino forwarded the monitoring signal conditionally to the ARDUINO control unit, after that ARDUINO Wi-Fi module upload the transmitted data to Thing Speak cloud. Data transferring between Arduino and ARDUINO, a filtering algorithm is used to remove the invalid and incomplete signals. After that the signals are sent to the cloud to reserve through the Internet. The Home/domestic sensor monitoring information could be visualized through a

web page and mobile application provided by Thing Speak service

4. RESULTS

4.1 Arduino IDE

What is Arduino IDE?

The Arduino Integrated Development Environment - or Arduino Software (IDE) - contains a text editor for writing code, a message area, a text console, a toolbar with buttons for common functions and a series of menus. It connects to the Arduino hardware to upload programs and communicate with them.

A program for Arduino hardware may be written in any programming language with compilers that produce binary machine code for the target processor. Atmel provides a development environment for their 8-bit AVR and 32-bit ARM Cortex-M based microcontrollers: AVR Studio (older) and Atmel Studio (newer).

4.2 Schematic diagram

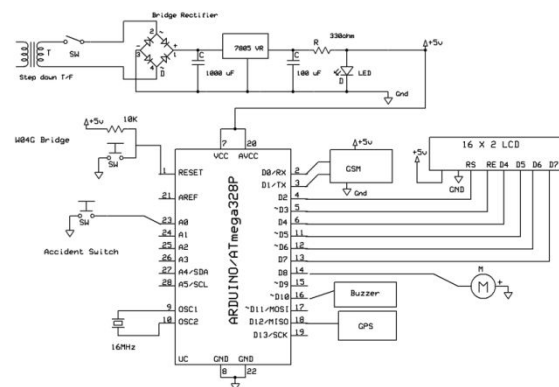
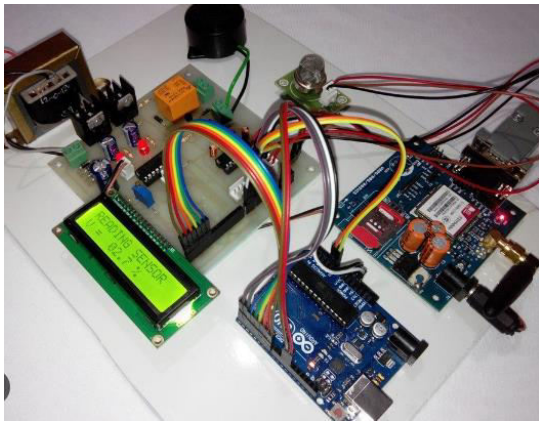
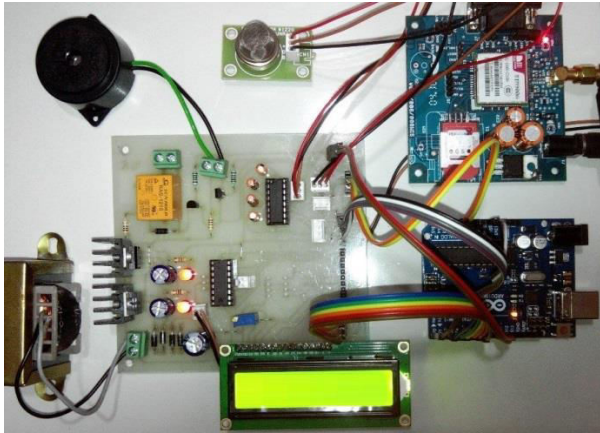

Fig. 2: Schematic diagram of proposed system.

4.3 Hardware implementation



5. CONCLUSION

An effective GSM based Home/domestic sensor Monitoring structure to monitor sensor parameters using GSM is implemented. The developed device monitored the Home/domestic sensor monitoring and an alert on GSM server when the harmful gases like smoke, temperature, fire crosses the threshold level. We designed and implemented internet of things-based Home/domestic security system we obtained efficient results. Integrated all sensors to arduino and monitor the display and post into Internet we can monitor anywhere in the world. This Home/domestic security system enhance the previous system provides high effective secured.

REFERENCES

- [1] P. Zheng et al., "Smart manufacturing systems for Industry 4.0: Conceptual framework, scenarios, and future perspectives," *Frontiers of Mechanical Engineering*, 2018, doi: 10.1007/s11465-018-0499-5.
- [2] A. Glória, F. Cercas, and N. Souto, "Design and implementation of an GSM gateway to create smart environments," in *Procedia Computer Science*, 2017, doi: 10.1016/j.procs.2017.05.343.
- [3] J. Rigelsford, "GSM Networks: Protocols, Terminology and Implementation," *Sens. Rev.*, 2003, doi: 10.1108/sr.2003.08723bae.001.
- [4] S. Redl, M. Weber, and W. H. Y. Are, *GSM and Personal*. 1998.
- [5] B. Schallock, C. Rybski, R. Jochem, and H. Kohl, "Learning Factory for Industry 4.0 to provide future skills beyond technical training," in *Procedia Manufacturing*, 2018, doi: 10.1016/j.promfg.2018.03.156.
- [6] G. Dinardo, L. Fabbiano, and G. Vacca, "A smart and intuitive machine condition monitoring in the Industry 4.0 scenario," *Meas. J. Int. Meas. Confed.*, 2018, doi: 10.1016/j.measurement.2018.05.041.
- [7] A. Pantelopoulos and N. G. Bourbakis, "A survey on wearable sensor-based systems



for health monitoring and prognosis,” *IEEE Transactions on Systems, Man and Cybernetics Part C: Applications and Reviews*, 2010, doi: 10.1109/TSMCC.2009.2032660.

- [8] Schütze, N. Helwig, and T. Schneider, “Sensors 4.0 - Smart sensors and measurement technology enable Industry 4.0,” *J. Sensors Sens. Syst.*, 2018, doi: 10.5194/jsss-7-359-2018. [9] Z.

Liu, “Hardware Design of Smart Home System based on zigBee Wireless Sensor Network,” *AASRI Procedia*, 2014, doi: 10.1016/j.aasri.2014.08.013.

- [9] G. Appelboom et al., “Smart wearable body sensors for patient self-assessment and monitoring,” *Archives of Public Health*, 2014, doi: 10.1186/2049-3258-72-28.