



International Journal for Innovative Engineering and Management Research

A Peer Reviewed Open Access International Journal

www.ijiemr.org

COPY RIGHT

2017 IJIEMR. Personal use of this material is permitted. Permission from IJIEMR must be obtained for all other uses, in any current or future media, including reprinting/republishing this material for advertising or promotional purposes, creating new collective works, for resale or redistribution to servers or lists, or reuse of any copyrighted component of this work in other works. No Reprint should be done to this paper, all copy right is authenticated to Paper Authors

IJIEMR Transactions, online available on 27th June 2017. Link :

<http://www.ijiemr.org/downloads.php?vol=Volume-6&issue=ISSUE-4>

Title: Improved Power Quality And Reactive Power Compensation In A Grid Connected System For Non-Linear Loads Using Fuzzy Controlled Dstatcom.

Volume 06, Issue 04, Page No: 1287 - 1294.

Paper Authors

***I.VIDYASREE, M.RAMANJANEYULU.**

* Dept of EEE, VRS&YRN College of Engineering & Technology, Chirala.



USE THIS BARCODE TO ACCESS YOUR ONLINE PAPER

To Secure Your Paper As Per **UGC Guidelines** We Are Providing A Electronic Bar Code

IMPROVED POWER QUALITY AND REACTIVE POWER COMPENSATION IN A GRID CONNECTED SYSTEM FOR NON-LINEAR LOADS USING FUZZY CONTROLLED DSTATCOM

***I.VIDYASREE, **M.RAMANJANEYULU**

PG Scholar, Dept of EEE, VRS&YRN College of Engineering & Technology, Chirala;
Prakasam (Dt); Andhra Pradesh, India.

Assistant Professor, Dept of EEE, VRS&YRN College of Engineering & Technology, Chirala;
Prakasam (Dt); Andhra Pradesh, India.

ABSTRACT:

A Power quality problem is an occurrence manifested as a nonstandard voltage, current or frequency that results in a failure or a mis-operation of end user equipments. Due to deteriorate the quality of power, other customers which are connected to the same PCC also experiences the poor quality of power so whole system gets affected by these non-linear loads. D-STATCOM solves these problems more efficiently and reliably. Many application of D-STATCOM is in the power systems at the distribution level. It compensates the reactive power, improves power factor, enhances voltage regulation and compensate at fault condition. Here in this project the main concern is harmonic distortion due to non-linear loads and mitigation of current harmonics using D-STATCOM and compensation of reactive power for load and maintains the grid reactive power near to zero using MATLAB/SIMULATION. A fuzzy based controller is also used and compared with conventional controller. Finally performance of the both controllers are compared and analyzed.

I INTRODUCTION

STATCOM [1] and D-STATCOM have similar strategies but objective of these two are different and covers the different area of objective. When STATCOM is connected to the distribution side then it is called D-STATCOM. D STATCOM has the additional advantage in the power systems. It has its own applications viz. to improve power factor, to improve voltage regulation, to maintain three-phase balanced voltage and compensate at the fault condition. DSTATCOM is a shunt connected power electronic device which used self-commutated device like IGBT, IGCT etc. Voltage source converter (VSC) is the main part of the STATCOM. It injects the compensated or harmonic component of the

current to cancel out the other harmonic frequency component (other than power frequency). So it acts as an active power filter [3].

II POWER QUALITY

Power quality deals with maintaining a pure sinusoidal waveform of voltage and frequency. Voltage quality concern with deviation of voltage from ideal voltage (sinusoidal) it is a single frequency sine wave at rated magnitude and frequency with no harmonics. Current quality is a complimentary term of voltage quality concern with a deviation from the ideal

current. Current should be in phase with the voltage. According to IEEE standard 1100, “power quality is the concept of powering and grounding sensitive equipment in a manner that is suitable to the operation of that equipment”.

1 Power quality problems

There are so many problems related with quality of power. Here the main concern with the poor power quality with nonlinear loads. Non-linear loads can cause voltage and current distortion. That is it changes its shape other than sinusoidal.

2 Harmonic Distortion

Harmonic components are those waveforms which have the frequency as an integer multiple of the fundamental. Any periodic waveform which is non-sinusoidal can be divided into fundamental and non fundamental components. Every nth harmonic will have a frequency n times that of fundamental frequency [3].

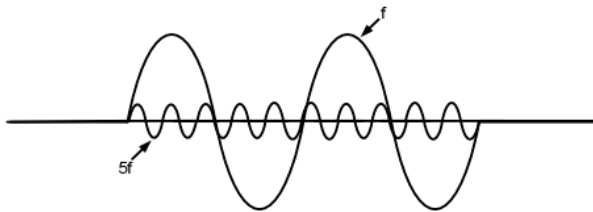

Figure 1: Fundamental component and 5th harmonic component

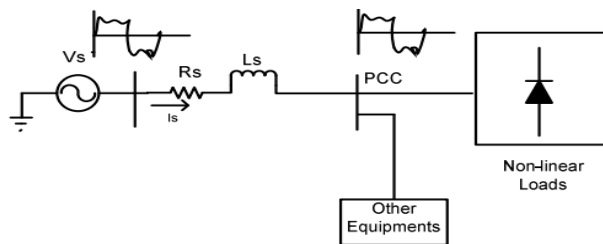

Figure 2: Power System with non-linear loads Voltage at point of common coupling

$$V_{pcc} = V_s - L_{s1} \left(\frac{di_s}{dt} \right)$$

$$i_s = i_{s1} + \Sigma i_{sh}$$

$$V_{pcc} = \left(V_{sh} - L_{s1} \left(\frac{di_{s1}}{dt} \right) \right) - \left(L_{s1} - \left(\frac{di_{sh}}{dt} \right) \right)$$

$$V_{pcc} = V_{pcc1} - V_{pcc(\text{distortion})}$$

$$V_{pcc1} = \left(V_{sh} - L_{s1} \left(\frac{di_{s1}}{dt} \right) \right)$$

$$V_{pcc(\text{distortion})} = \left(L_{s1} - \left(\frac{di_{sh}}{dt} \right) \right)$$

Non-linear loads draw reactive power. So input power factor is also get poor.

Line current and Total Harmonic Distortion (THD)

$$v_s = \sqrt{2} V_s \sin \omega t$$

$$i_s = \sqrt{2} I_{s1} \sin(\omega_1 t - \phi_1) + \Sigma \sqrt{2} I_{sh} \sin(\omega_n t - \phi_h)$$

$$i_s = i_{s1}(t) + \Sigma i_{sh}(t)$$

$$I_s = (I_{s1}^2 + \Sigma i_{sh}^2)$$

If we remove fundamental, then only ripple will be left

$$i_{\text{distortion}} = (i_s^2 - i_{s1}^2)^{\frac{1}{2}} = (\Sigma i_{sh}^2)^{\frac{1}{2}}$$

$$\%THD = I_{\text{distortion}} * \frac{100}{I_{s1}}$$

$$\%THD = \sqrt{I_s^2 - I_{s1}^2} * \frac{100}{I_{s1}}$$

III Principle of D-STATCOM

It is shunt connected at the distribution side of the power systems. A D-STATCOM is a

controlled reactive source, which includes a Voltage Source Converter (VSC) and a DC link capacitor connected in shunt, capable of generating and/or absorbing reactive power. The operating principles of a D-STATCOM are based on the exact equivalence of the conventional rotating synchronous compensator [5]. The AC terminals of the VSC are connected to the Point of Common Coupling (PCC) through an inductance, which could be a filter inductance or the leakage inductance of the coupling transformer, as shown in Figure 3. The DC side of the converter is connected to capacitor, which carries the input ripple current of the converter and reactive energy storage element. This capacitor could be charged by voltage source or inverter. When AC output voltage of inverter is equal to terminal voltage, then there is no reactive power exchange. If there is a difference between these voltages the only reactive power exchange occurs. The control strategies studied in this paper are applied with a view to studying the performance of a D-STATCOM for reactive power compensation and harmonic mitigation.

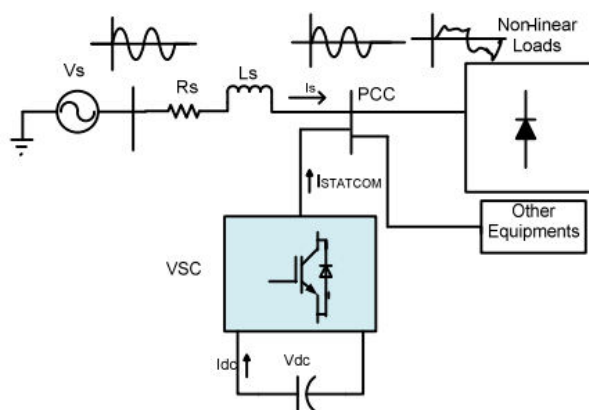

Figure 3: Power system with D-STATCOM

Configuration and operation of DSTATCOM
D-STATCOM has 3-phase voltage source converter, capacitor at DC side of inverter is connected with the electrical system at the

PCC. The instantaneous controllable 3-phase output voltage is generated from DC voltage at fundamental frequency. The pulse is generated by the hysteresis current controller which takes the difference of reference current and actual source current and minimise the error and controls the current and generate 3-phase output voltage and injects capacitive or inductive current according to the nature of load [4].

Mathematical Expression for system [3]

Total instantaneous power delivery drawn by non-linear load

$$P_L(t) = P_{s1}(t) + P_r(t) + P_{sh}(t)$$

Real power supplied by source-

$$P_s = P_{s1}$$

Reactive power supplied by source-

$$Q_s = 0$$

Real power drawn by the load-

$$P_L = P_{s1} + P_{sh}$$

Reactive power drawn by the load-

$$Q_L = Q_{s1} + Q_{sh}$$

Real power supplied by the D-STATCOM-

$$P_{STATCOM} = P_{sh} - P_{loss}$$

Reactive power supplied by D-STATCOM-

$$Q_{STATCOM} = Q_{s1} + Q_{sh}$$

Where P_{loss} component of STATCOM
From the single line diagram Figure 2

$$i_s(t) = i_L(t) + i_{STATCOM}(t)$$

When the phase of $V_{STATCOM}$ is in quadrature with $I_{STATCOM}$ without injecting real power the D-STATCOM can achieve the voltage sag mitigation. The shunt injecting current $I_{STATCOM}$ and 5 in Figure 3.3 can be expressed as equation (20 and 21)

$$I_{STATCOM} = I_L - I_s = I_L - \left(\frac{V_{th} - V_L}{Z_{th}}\right)$$

$$V_L = V_{th} + (I_{STATCOM} - I_L)Z_{th}$$

$$I_s = (V_{th} - V_L)/Z_{th}$$

IV CONTROL STRATEGY

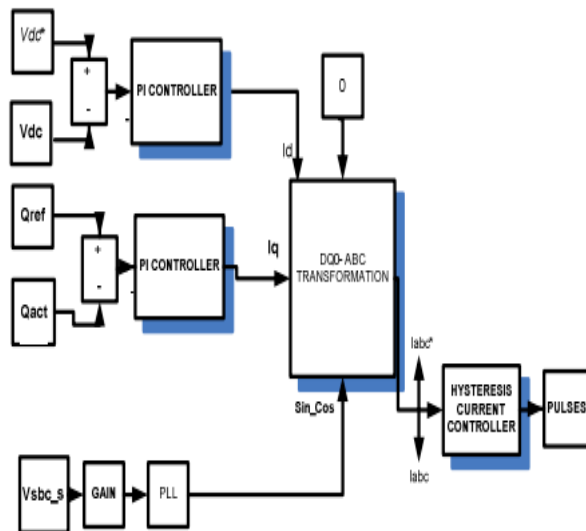

Figure 4: Control Strategy to generate pulses

V MATHEMATICAL MODELLING

The direct and quadrature axis component of current are:

$$I_d = \left(K_p + \frac{K_i}{s}\right) * (V_{DC}^* - V_{DC})$$

$$I_q = \left(K_p + \frac{K_i}{s}\right) * (Q_{grid}^* - Q_{grid})$$

1 d-q-0 to a-b-c transformation

$$x_{abc} = K^{-1} x_{dq0}$$

$$= \sqrt{\frac{2}{3}} * \begin{bmatrix} \cos(\theta) & -\sin(\theta) & \frac{1}{\sqrt{2}} \\ \cos\left(\theta - \frac{2\pi}{3}\right) & -\sin\left(\theta - \frac{2\pi}{3}\right) & \frac{1}{\sqrt{2}} \\ \cos\left(\theta + \frac{2\pi}{3}\right) & -\sin\left(\theta + \frac{2\pi}{3}\right) & \frac{1}{\sqrt{2}} \end{bmatrix} \begin{bmatrix} x_d \\ x_q \\ x_0 \end{bmatrix}$$

2 Hysteresis Current Controllers

In conventional hysteresis band (HB) current control, the switching signal is sent to the IGBT at the same arm (T1 and T4). The output of the HBC is directly connected to the transistor T1 and reverse is connected to the T4, therefore the transistor in the same leg is not simultaneously ON or OFF. IGBT are self commutated. Hysteresis Current Controller compares the actual and reference current and generates pulses for the inverter [5, 6].

If

$$i \leq (i^* - HB), \text{ then T1 in ON}$$

If

$$i \geq (i^* + HB), \text{ then T4 is ON}$$

VI FUZZY LOGIC CONTROLLER

L. A. Zadeh presented the first paper on fuzzy set theory in 1965. Since then, a new language

was developed to describe the fuzzy properties of reality, which are very difficult and sometime even impossible to be described using conventional methods. Fuzzy set theory has been widely used in the control area with some application to dc-to-dc converter system. A simple fuzzy logic control is built up by a group of rules based on the human knowledge of system behavior. Matlab/Simulink simulation model is built to study the dynamic behavior of dc-to-dc converter and performance of proposed controllers. Furthermore, design of fuzzy logic controller can provide desirable both small signal and large signal dynamic performance at same time, which is not possible with linear control technique. Thus, fuzzy logic controller has been potential ability to improve the robustness of dc-to-dc converters. The basic scheme of a fuzzy logic controller is shown in Fig 5 and consists of four principal components such as: a fuzzification interface, which converts input data into suitable linguistic values; a knowledge base, which consists of a data base with the necessary linguistic definitions and the control rule set; a decision-making logic which, simulating a human decision process, infer the fuzzy control action from the knowledge of the control rules and linguistic variable definitions; a de-fuzzification interface which yields non fuzzy control action from an inferred fuzzy control action [10].

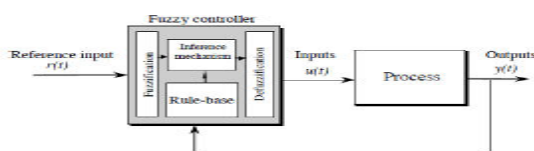

Fig.5. General Structure of the fuzzy logic controller on closed-loop system

The fuzzy control systems are based on expert knowledge that converts the human linguistic concepts into an automatic control strategy without any complicated mathematical model [10]. Simulation is performed in buck converter to verify the proposed fuzzy logic controllers.

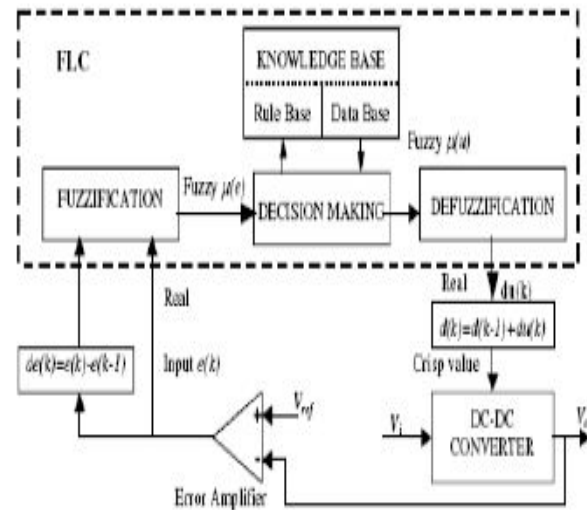

Fig.6. Block diagram of the Fuzzy Logic Controller (FLC) for dc-dc converters

A. Fuzzy Logic Membership Functions:

The dc-dc converter is a nonlinear function of the duty cycle because of the small signal model and its control method was applied to the control of boost converters. Fuzzy controllers do not require an exact mathematical model. Instead, they are designed based on general knowledge of the plant. Fuzzy controllers are designed to adapt to varying operating points. Fuzzy Logic Controller is designed to control the output of boost dc-dc converter using Mamdani style fuzzy inference system. Two input variables, error (e) and change of error (de) are used in this fuzzy logic system. The single output variable (u) is duty cycle of PWM output.

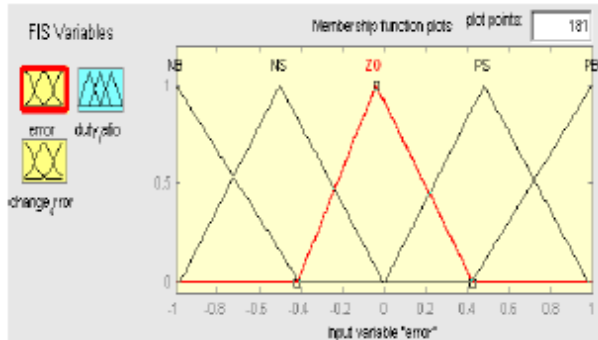

Fig. 7. The Membership Function plots of error

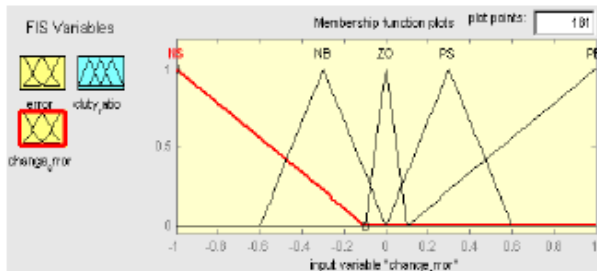

Fig. 8. The Membership Function plots of change error

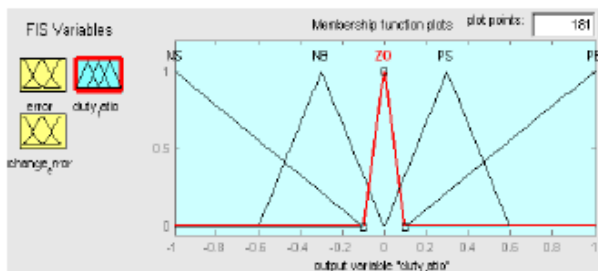

Fig.9. the Membership Function plots of duty ratio

B. Fuzzy Logic Rules:

The objective of this dissertation is to control the output voltage of the boost converter. The error and change of error of the output voltage will be the inputs of fuzzy logic controller. These 2 inputs are divided into five groups; NB: Negative Big, NS: Negative Small, ZO:

Zero Area, PS: Positive small and PB: Positive Big and its parameter [10]. These fuzzy control rules for error and change of error can be referred in the table that is shown in Table II as per below:

Table I

Table rules for error and change of error

| e/ce | NB | NM | NS | ZO | PS | PS | PB |
|------|----|----|----|----|----|----|----|
| NB | NB | NB | NB | NB | NM | NS | ZO |
| NM | NB | NB | NB | NM | NS | ZO | PS |
| NS | NB | NB | NM | NS | ZO | PS | PM |
| ZO | NB | NM | NS | ZO | PS | PM | PB |
| PS | NM | NS | ZO | PS | PM | PB | PB |
| PM | NS | ZO | PS | PM | PB | PB | PB |
| PB | ZO | PS | PM | PB | PB | PB | PB |

VII. MATLAB/SIMULINK RESULTS

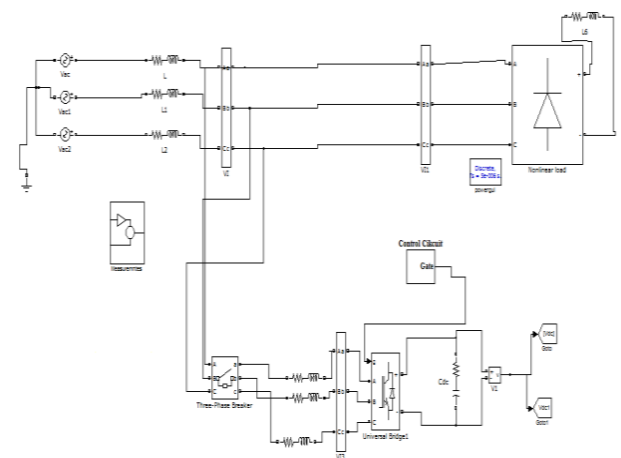

Fig.9 shows the matlab/Simulink model of proposed system with PI controller

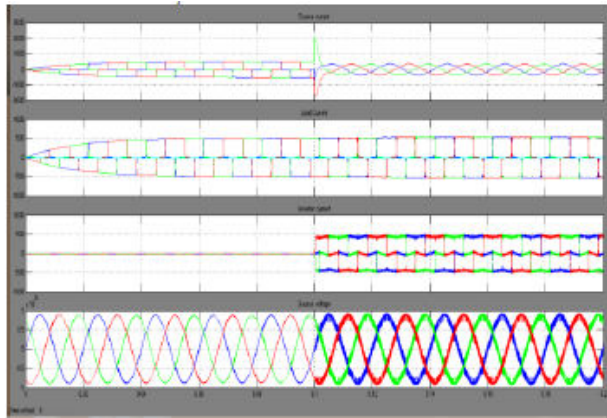

Fig.10 shows the simulation waveforms of source current, load current, injected current and source voltage

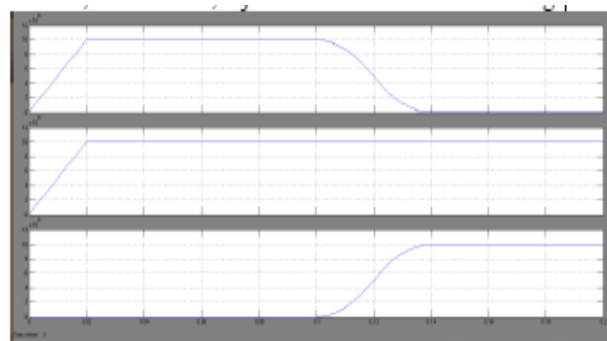

Fig.11 shows the reactive power generated by grid, demanded by load and supplied by D-Statcom

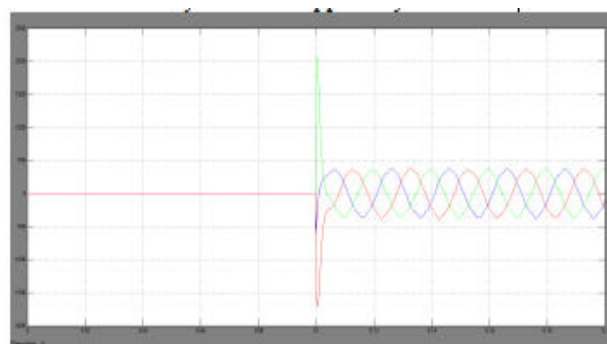

Fig.12 shows the D-STATCOM injected harmonic current

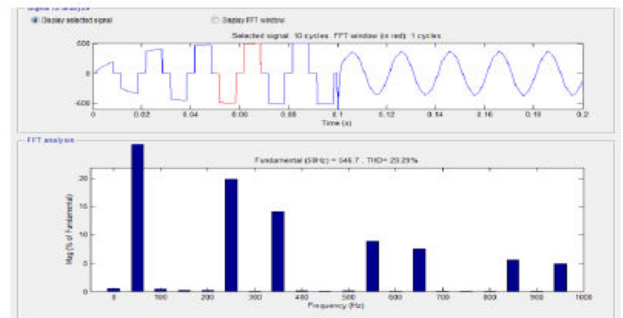

Fig.13 shows the THD response of source current before compensation

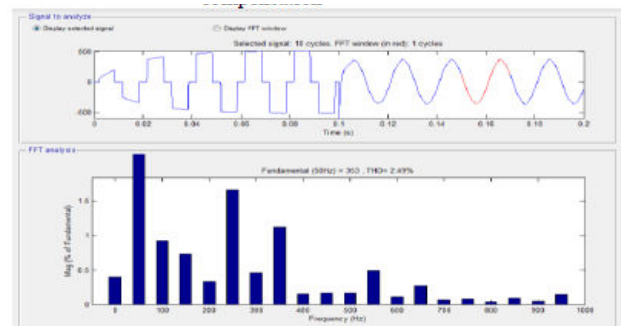

Fig.14 shows the THD response of source current after compensation

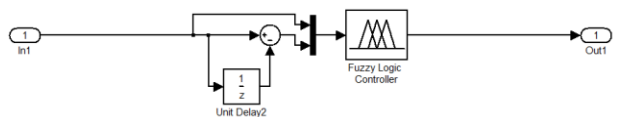

Fig.15 shows the fuzzy logic controller system

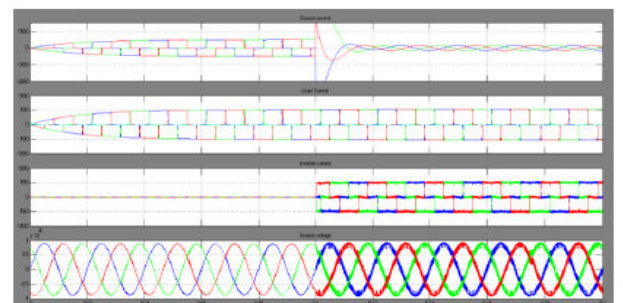

Fig.16 shows the simulation waveforms of source current, load current, injected current and source voltage with fuzzy logic controller

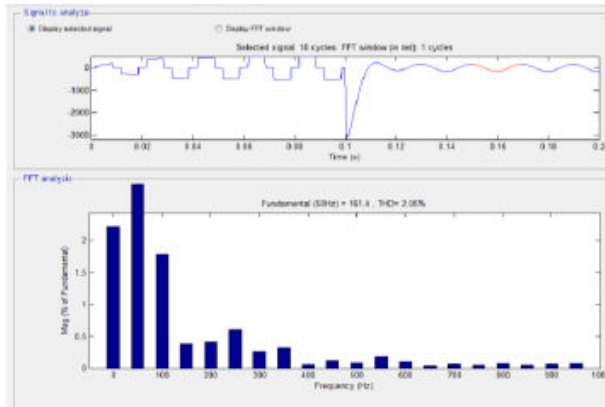

Fig.17 shows the THD response of source current after compensation with fuzzy logic controller

VIII CONCLUSION

The model is designed and analyzed its performance on the basis of reactive power compensation and power quality improvement. In this model, PI and Fuzzy controller are used. The proposed concept is simulated using matlab/Simulink and performance is observed doing THD analysis. From that we can observe that fuzzy controlling technique is having much better performance than PI controller.

REFERENCES

[1] K. R. Padiyar. "FACTS Controllers in Power Transmission and Distribution".
 [2] Narain G. Hingorani, Laszlo Gyugyi. "Understanding FACTS Concept and technology of flexible AC transmission systems".
 [3] Manam Ravindra, Devineni Gireesh Kumar. "Design Of VSI Based STATCOM For Eliminating Harmonic Currents Due To Non Linear Load And To Compensate The Reactive Power In A Grid Connected System", IJERA Volume 2, Issue 6, pp. 436-443, (2012).
 [4] Vandana S Pai, Jo Joy. "Reactive Power Compensation and Harmonic Mitigation in a

Grid connected system using STATCOM", IJAREEIE, Volume 3, Special Issue 5, (2014).
 [5] Meenakshi Rastogi, Abdul Hamid Bhat. "Reactive Power Compensation Using Static Synchronous Compensator (STATCOM) with Conventional Control Connected with 33kv Grid", Proceedings of 2nd international conference of RA ECS, IEEE, pp. 1-5, (2015).
 [6] Vandana S Pal, Joy. "Reactive power compensation and in a lossless transmission line by the application of Statcom", Proceedings of Second IRF International Conference, Cochin, India, ISBN: 978-93-84209-43-8, (2014).
 [7] Dragan Jovcic. "Phase Locked Loop System for FACTS," IEEE Transactions on power systems, Volume 18, Issue 3, (2003).
 [8] "IEEE Transactions on Power Systems", Volume 7, Issue 1, pp.243-249, (1992).
 [9] Shaik Khaja Gareeb, Nawaz, Shaik Hameed. "Mitigation of Power Quality Problems by using D-Statcom", International Journal of Recent Advances in Engineering & Technology, Volume 1, issue 3, (2013).
 [10] Saurabh S. Kulkarni, Mr. Naveen Kumar Mucha. "A Matlab/Simulink Model for the control scheme utilized to improve power quality of Wind Generation System connected to grid", International Journal of Innovative Research in Advanced Engineering, Volume 1, Issue 6, (2014).