



COPY RIGHT

2017 IJIEMR. Personal use of this material is permitted. Permission from IJIEMR must be obtained for all other uses, in any current or future media, including reprinting/republishing this material for advertising or promotional purposes, creating new collective works, for resale or redistribution to servers or lists, or reuse of any copyrighted component of this work in other works. No Reprint should be done to this paper, all copy right is authenticated to Paper Authors

IJIEMR Transactions, online available on 14th June 2017. Link :

<http://www.ijiemr.org/downloads.php?vol=Volume-6&issue=ISSUE-4>

Title: Reliable Handling Of Road Rules And Speed Measurement In Vehicle Transportation.

Volume 06, Issue 04, Page No: 953 - 956

Paper Authors

***K. SANGEETH KUMAR,** JAGATHA MADHAVI SATYA LAKSHMI**

* Dept of ECE, Kakinada Institute of Engineering & Technology



USE THIS BARCODE TO ACCESS YOUR ONLINE PAPER

To Secure Your Paper As Per **UGC Guidelines** We Are Providing A Electronic Bar Code

Reliable Handling of Road Rules and Speed Measurement in Vehicle Transportation

* K. SANGEETH KUMAR **JAGATHA MADHAVI SATYA LAKSHMI.

Abstract— This paper focuses on the development of a system for vehicle classification, Speed measuring and controlling, Weight measuring in bus and truck, Navigation routing, Signal notifications, and Height notation in the road side areas. In this the Mixed Signal Processor is used for the controlling of the whole system. This controller unit is placed in both the vehicle as well as road side. An algorithm based on this is Vehicular Ad-hoc Network, from this algorithm the vehicle and road side networks could communicate with each other wirelessly. The developed sensor system is compact, wireless, and inexpensive. Vehicle classification is useful in a number of applications, including road maintenance and management, roadway design, emissions evaluation, multimode traffic model development, traffic control, traffic signal design, and toll systems development. Inductive speed sensors give a voltage output when subjected to a changing magnetic field. The field is set up by a magnet inside the sensor body and changes when ferromagnetic teeth are passed beneath the sensor (no magnets are required in the target). The voltage increases with increasing speed and with a reduction of the gap between the sensor and the target. Speed control based on RTC and area using VANET with vehicle speed analysis using on board unit and vehicle classification and alerting system also we implement. In that field vehicle control the emission of vehicle depends upon traffic signal design and traffic analysis using traffic flow and shortest path preference. And also implement signal alert for vehicle turns in tunnels or some congested path roadways. Load sensor is using for load analysis for vehicle and mention the over ton warning system and vehicle scheduling system also implement by using Real Time Clock (RTC).

Key words: Mixed Signal Processor, Inductive Speed Sensor, Load Cell, RTC, RFID Tag, Infrared Sensor, Display Unit, SDRAM

I. INTRODUCTION

A new kind of ad hoc network is hitting the streets VANETs. In these networks, vehicles communicate with each other and possibly with a roadside infrastructure to provide a long list of applications varying from transit safety to driver assistance and internet access. In these networks, knowledge of the real time position of nodes is an assumption made by most protocols, algorithms, and applications. This is a very reasonable assumption, since GPS receivers can be installed easily in vehicles, a number of which already comes with this technology. But as VANETs advance into critical areas and become more dependent on localization systems, GPS is starting to show some undesired problems such as not always being available or not being robust enough for some applications. For this reason, a number of other localization techniques such as dead reckoning, cellular localization, and image video Localization have been used in VANETs to overcome GPS limitations. This paper describes a sensing system that can be placed adjacent to a road and can be used for vehicle routing, vehicle classification, and vehicle speed measurements. The proposed system can make these traffic

measurements reliably for traffic in the lane adjacent to the sensors. The developed signal processing algorithms enable the sensor to be robust to the presence of traffic in other lanes of the road. Organized traffic generally has well established priorities lanes, right of way, and traffic control at inter sections. Events which disrupt the flow and may cause traffic to degenerate into a disorganized mess include road construction, collisions and debris in the roadway. On particularly busy freeways, a minor disruption may persist in a phenomenon known as traffic waves. A complete breakdown of organization may result in traffic congestion and gridlock. Simulations of organized traffic frequently involve queuing theory, stochastic processes and equations of mathematical physics applied to traffic flow.

Several technologies are involved in Vehicular Ad hoc Networks, especially as enablers of Intelligent Transportation Systems (ITS). These are GSM, UMTS, Wi-MAX limited Wi-Fi and a new and specific technology thought for this kind of applications, namely Wireless Access in Vehicular Environments (WAVE). Vehicular Ad-hoc Network (VANET) communication is shown in the figure (1), it basically used to provide various services to its

user. Vehicular networks pose a number of unique challenges.

This paper is organized as follows. In Section II, the signal strength and sensing system configuration is discussed. In Section III, the detection performance of the system is

II. RELATED WORK

This chapter presents the existing method they used on the development of a portable road side magnetic sensor system for vehicle counting, classification, and speed measurement. This system is used in the adjacent lanes only, not applicable for non adjacent lanes.

This could only do the operation for only one vehicle at a time. This operation is more accurate because of the low number of vehicles, but in countries like India single lane process is not possible. It gives some reference how to create a system for more number of vehicles in a lane that is non adjacent.

A. Vehicle Detection and Counting:

Fig. 2 shows the configuration of the sensing system, which includes four three-axis AMR sensors placed on the side of the road. The objective of the system is to count the number of vehicles, measure the speed, and classify the vehicles that pass in the adjacent lane. Magnetic field readings of the x-, y-, and z-axes, with the sensor placed at the center of the road lane. Here, the x-axis is along the longitudinal direction of travel of the vehicles, the y-axis is perpendicular to the direction of travel of the vehicles, and the z-axis is perpendicular to the road surface and upward. The recorded signals from the sensors placed adjacent to the road are more uniform compared to the case that the sensors are on the road. This behavior makes the detection more reliable, because large oscillations in the signals can cause errors due to the double detection of a single vehicle. In particular, it was observed that the signals measured along the z-axis have very similar patterns for a large variety of vehicles. Hence, magnetic readings of the z-axis of sensor 1 are used for detecting and counting the passing vehicles in the adjacent lane. A threshold of 30 counts was used as the vehicle detection threshold. This threshold was experimentally selected. If it is set very high, smaller vehicles will not be detected, and if it is set very low, a higher percentage of vehicles that pass in the nonadjacent lane will be detected. Although a robust algorithm is developed to reduce the false detections due to vehicles that pass in the nonadjacent lane, it is good to avoid false detections at an early stage to have a minimized final false detection rate. Signals from 188 vehicles driving in the adjacent lane were recorded in two days during afternoon hours, with clear-sky conditions. Out of the 188 vehicles, 186 vehicles created a large-enough signal to be detected, resulting in a detection rate of 99%.

B. Speed Estimation:

Speed estimation of a passing vehicle is required to measure the vehicle length, which is used for vehicle classification.

presented. The method that was developed to make the system robust to traffic in the nonadjacent lane is described in Section IV. In Section V, the speed estimation method is described. Vehicle classification is discussed in Section VI. A method of counting the number of vehicles

Speed estimation also has other applications; for example, it has been used by researchers to estimate the queue length for ramp-metering algorithms. Transportation agencies use estimated speed information for setting speed limits and timing traffic signals. There are some proposed methods in the literature for speed measurement using a single magnetic sensor, however, those methods provide only an average estimate of the speed over a number of passing vehicles. To measure individual vehicle speed, two longitudinally spaced sensors are required. The conventional method for estimating speed with two magnetic sensors is based on the detection times of the two sensors. If the detection times for sensors —a1 and —b1 are $t_{a,ON}$, $t_{a,OFF}$, $t_{b,ON}$, and $t_{b,OFF}$, an estimate of the speed can be calculated as

C. Vehicle Classification:

Vehicle classification is useful in a number of applications, including road maintenance and management, roadway design, emissions evaluation, multimode traffic model development, traffic control, traffic signal design, and toll systems development. The classification method proposed in this section is based on using the magnetic length and an estimate of the average vertical height of the passing vehicles. Vehicles are classified into the following four classes. They are Sedans, SUVs, pickups, and vans, Buses, two- and three-axle trucks, articulated buses and four- to six-axle trucks.

III. SYSTEM DESIGN

As a new proposed technology developed here for enhancing the transportation monitoring and maintenance for discipline transporting, has reached to a new level in human innovation aspect. The block diagram of proposed system design in vehicle unit is shown in figure 3. This prototype is made for improving the safety and reduces the traffic in the cities and over traffic areas. Bellow the road side unit has shown these two together can do the things we wanted from the proposed prototype.

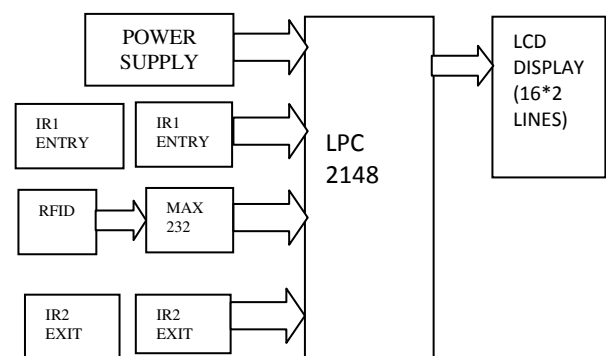

Block Diagram of Proposed System in Vehicle Unit The block diagram of proposed system design in road-side unit is shown in figure Both the vehicle and road side units are communicate with each other by the wireless transceiver, they transferring their dates to one another. The works donned by these systems are discussed bellow.

A. Vehicle Routing:

The traffic information flowing in the network may affect the traffic decisions. Traffic View is a mechanism that can be routed with a vehicle as the future aspect. The vehicles which have Traffic view device installed will broadcast the traffic information using short range wireless communication. In contrast, applications such as traffic and congestion monitoring require collecting information from vehicles that span multiple kilometers More in general, we can distinguish between intra and inter-vehicle communications. The first term is used to describe communications within a vehicle, while the second one represents communications between vehicles, or vehicles and sensors, placed in or on various locations, such as roadways, signs, parking areas, and so on. From this we can take decision to which way to go and which way not to.

B. Signal Monitoring:

Today unmanaged traffic is generating many problems to the public such as having to wait for so much time in the intersections, accidents to the careless driver behavior etc..The vehicles that arrive towards traffic signal are grouped into the platoons which are assumed to be equal sized jobs. Then these jobs are scheduled using an online algorithm called Oldest Job First (OJF) algorithm to reduce the delay across the intersection. The traffic signal timing can be made dynamic by determining the vehicle density of the platoon and depending upon that the green times are calculated and vehicles are evacuated, thereby minimizing the waiting time.

C. Speed Measuring and Controlling:

This system mainly uses photoelectric sensor, electrical power source and micro-controller for controlling the vehicle speed. The arrangement of the components used in this system. By using this simple system we can control automatically the speed of the vehicle. The vehicle will move with designated speed (low speed) of the control system even though the driver wants to drive the vehicle with high velocities. The system will start working only

when we applying the brake a number of times. The brake will act like a switch. When the brake is pressed the circuit will be completed by the battery which will start conducting the charge, which will be stored in the toroidal coil. Due to high valued resistor in the parallel circuit and low resistance of coil, 95% of charge will be stored within the coil. This charge will create a magnetic field around the coil that will pull the controlling rod. This controlling rod movement will be used for controlling the fuel supply system for varying the fuel rate entering into the combustion chambers.

D. Height Notation in the Road Side Areas:

In the world the vehicles may different according to their purposes some of them are used for domestically and others are used for industrial. They also termed as heavy and light vehicles by their usage. In some cases their height may vary, all transportation are not donned in the same path ways they might have face some paths like tunnels, bridges, etc.. If the vehicles passes through those ways then they have face some problems like struck into them or take some extra time for reaching other directions if the already gone to the problem areas. Thus the infrared sensor has placed in the way that has bridge or tunnel in it. If the vehicle cuts the IR rays then they alerted to take diversion by the RFID tag. An incident happened in Australia that while transporting giraffe from one place to the other a bridge is hit the giraffe's head and died. These kind of problems may avoided by this application.

IV. CONCLUSION

The implementation of proposed system is to create a reliable handling of road rules in vehicle transportation using VANET. As that mentioned that reliable system it is far more easy and fitted system for the handling of road rules. This system is suitable for every environment. This could be more accurate system for various operations at a time.

From this system the vehicles speed controlling for the vehicles in the city areas, load monitoring in bus/truck is donned then if load is higher in trucks it won't let the truck to be move that is ignition system is stopped and for bus the over load is detected and message send to the transport corporation for alerting the rush in the particular area and in the particular time thus they may put some extra busses to there, the signal monitoring is used to avoid the waiting times in the traffic signals, the height measure is donned for avoiding the over heighted vehicle to take the wrong path if there is any tunnels or bridges they less higher for them to cross, the routing process is donned for the persons to take shorter distance path or less traffic path by the VANET based algorithms. This system is avoiding the unwanted traffic and reduces the rushes in the peak areas in peak hour.

REFERENCES

- [1] Saber Taghvaeeyan and Rajesh Rajamani, —Portable roadside sensors for vehicle counting, classification, and speed measurement| IEEE transactions on intelligent transportation systems, vol. 15, no. 1, Pp. 1524-9050, 2014.
- [2] S. Jeng and S. Ritchie, —Real-time vehicle classification using inductive loop signature data,| Transp. Res. Rec., J. Transp. Res. Board, vol. 2086, pp. 8–22, 2008.
- [3] S. Gupte, O. Masoud, R. F. K. Martin, and N. P. Papanikolopoulos, —Detection and classification of vehicles,| IEEE Trans. Intell. Transp. Syst., vol. 3, no. 1, pp. 37–47, Mar. 2002.

- [4] H. Cheng, H. Du, L. Hu, and C. Glazier, —Vehicle detection and classification using model-based and fuzzy logic approaches,|| *Transp. Res. Rec., J. Transp. Res. Board*, vol. 1935, pp. 154–162, 2005.
- [5] J. Medina, M. Chitturi, and R. Benekohal, —Effects of fog, snow, and rain on video detection systems at intersections,|| *Transp. Lett., Int. J. Transp. Res.*, vol. 2, no. 1, pp. 1–12, Jan. 2010.
- [6] M. J. Caruso and L. S. Withanawasam, —Vehicle detection and compass applications using AMR magnetic sensors,|| in *Sens. Expo Proc.*, 1999, pp. 477–489.
- [7] S. Cheung, S. Coleri, B. Dundar, S. Ganesh, C. Tan, and P. Varaiya, —Traffic measurement and vehicle classification with single magnetic sensor,|| *Transp. Res. Rec., J. Transp. Res. Board*, vol. 1917, pp. 173–181, 2005.
- [8] S.Kaewkamnerd,J.Chinrungrueng,R. Pongthornseri, and S. Dumnin, —Vehicle classification based on magnetic sensor signal,|| in *Proc. IEEE ICIA*, 2010, pp. 935–939.
- [9] M. Bottero, B. Dalla Chiara, and F. P. Deflorio, —Wireless sensor networks for traffic monitoring in a logistics center,|| *Transp. Res.—Part C: Emerg. Technol.*, vol. 26, pp. 99–124, Jan. 2013.
- [10] Y. He, Y. Du, and L. Sun, —Vehicle classification method based on singlepoint magnetic sensor,|| *Proc. Social Behav. Sci.*, vol. 43, pp. 618–627, 2012.
- [11] J. Lan and Y. Shi, —Vehicle detection and recognition based on a MEMS magnetic sensor,|| in *Proc. 4th IEEE Int. Conf. NEMS*, 2009, pp. 404–408.
- [12] Z. Feng and W. Mingzhe, —A new SVM algorithm and AMR sensor based vehicle classification,|| in *Proc. 2nd ICICTA*, 2009, pp. 421–425.

Faculty Details:



Name: **K.SANGEETH KUMAR**

Mr K.Sangeeth Kumar was born on June 15 1989. He graduated in ECE from Kakinada Institute of Engineering and Technology, korangi. Post-graduated in Embedded System from Kakinada Institute of Engineering and Technology, korangi. Presently He is working as a Asst Prof in Kakinada Institute of Engineering & Technology, Korangi. So far he is having 4 Years of Teaching Experience in various reputed engineering colleges. His special fields of interest included Embedded systems and Analog Electronics.

Student Details:



Name: **JAGATHA MADHAVI SATYA LAKSHMI**

Ms. J.Madhavi Satya Lakshmi was born in Mummdivaram, AP on February 16 , 1992 . She graduated from V.S.Lakshmi Engineering college, Matlapalem. Her special fields of interests included embedded systems, hardware design. Presently she is studying M.Tech in Kakinada Institute of Engineering and Technology-II, Korangi.



International Journal for Innovative Engineering and Management Research

A Peer Reviewed Open Access International Journal

www.ijemr.org