



# International Journal for Innovative Engineering and Management Research

A Peer Reviewed Open Access International Journal

www.ijiemr.org

**COPY RIGHT**



**ELSEVIER**  
**SSRN**

**2022 IJIEMR.** Personal use of this material is permitted. Permission from IJIEMR must be obtained for all other uses, in any current or future media, including reprinting/republishing this material for advertising or promotional purposes, creating new collective works, for resale or redistribution to servers or lists, or reuse of any copyrighted component of this work in other works. No Reprint should be done to this paper, all copy right is authenticated to Paper Authors

IJIEMR Transactions, online available on 12<sup>th</sup> Nov 2022. Link

[:http://www.ijiemr.org/downloads.php?vol=Volume-11&issue=Issue 12](http://www.ijiemr.org/downloads.php?vol=Volume-11&issue=Issue 12)

**DOI: 10.48047/IJIEMR/V11/ISSUE 11/28**

Title IOT HOME ELECTRICAL DEVICE STATUS MONITOR AND CONTROL SYSTEM

Volume 11, ISSUE 11, Pages: 182-186

Paper Authors

**T. Suhasini, B. Sathish Kumar, K. Saisri, S. Bhargav Reddy,**

**D. Manohar**



USE THIS BARCODE TO ACCESS YOUR ONLINE PAPER

To Secure Your Paper As Per **UGC Guidelines** We Are Providing A Electronic Bar Code

## IOT HOME ELECTRICAL DEVICE STATUS MONITOR AND CONTROL SYSTEM

T. Suhasini<sup>1</sup>, B. Sathish Kumar<sup>2</sup>, K. Saisri<sup>2</sup>, S. Bhargav Reddy<sup>2</sup>, D. Manohar<sup>2</sup>

<sup>1,2</sup>Department of Electrical and Electronics Engineering

<sup>1,2</sup>Malla Reddy Engineering College and Management Sciences, Medchal, Telangana

### ABSTRACT

The project aims at designing an advanced home automation system using Wi-Fi technology. The devices can be switched ON/OFF using a Personal Computer (PC) through Wi-Fi. Automation is the most frequently spelled term in the field of electronics. The hunger for automation brought many revolutions in the existing technologies. These had greater importance than any other technologies due to its user-friendly nature. These can be used as a replacement of the existing switches in home which produces sparks and also results in fire accidents in few situations. Considering the advantages of Wi-Fi an advanced automation system was developed to control the appliances in the house. Wi-Fi (Short for Wireless Fidelity) is a wireless technology that uses radio frequency to transmit data through the air. Wi-Fi has initial speeds of 1mbps to 2mbps. Wi-Fi transmits data in the frequency band of 2.4 GHz. It implements the concept of frequency division multiplexing technology. Range of Wi-Fi technology is 40-300 feet. The controlling device for the automation in the project is a Microcontroller. The data sent from PC over Wi-Fi will be received by Wi-Fi module connected to Microcontroller. Microcontroller reads the data and decides the switching action of electrical devices connected to it through Relays and Triac switches. The Microcontroller is programmed used embedded 'C' language.

**Keywords:** Home automation, IOT, Wi-Fi technology.

### 1. INTRODUCTION

The purpose of this project is to be controlling electrical devices with home remote using WIFI Module. The Wi-Fi modem provides the communication mechanism between the user and the microcontroller system by means of an IOT webpage. User can monitor the status and control multiple electrical devices by sending suitably formatted selection in IOT webpage to the microcontroller-based control system. These accessing commands are interpreted by microcontroller system and are validated. This system provides a modern era

automation system where we can control the status of the appliances from anywhere in the world. Here the devices to be controlled are interfaced to Microcontroller unit through switches Relay and controller which receives command through Wi-Fi module interfaced to it, processes them, and performs appropriate action on the devices. This project finds its applications in industrial environment, home automation and for any other commercial purposes.

#### 1.1 Project Overview

An embedded system is a combination of software and hardware to perform a

dedicated task. Some of the main devices used in embedded products are Microprocessors and Microcontrollers. Microprocessors are commonly referred to as general purpose processors as they simply accept the inputs, process it and give the output. In contrast, a microcontroller not only accepts the data as inputs but also manipulates it, interfaces the data with various devices, controls the data and thus finally gives the result. The “*IOT based home automation*” using ARDUINO microcontroller is an exclusive project which is used for automatic controlling of devices depending on the input given through Wi-Fi technology.

## 2. LITERATURE OF SURVEY

One of the buzzwords in the information technology is Internet of Things (IOT). The future is IOT which will transform the real-world objects into intelligent virtual objects. The IOT aims to unify everything in our world under a common infrastructure, giving us not only control of things around us, but also keeping us informed of the state of the things. In Light of this, present study addresses IOT concepts through systematic review of scholarly research papers, corporate white papers, professional discussions with experts and online databases. Moreover, this research article focuses on definitions, geneses, basic requirements, characteristics and aliases of Internet of Things. The main objective of this is to provide an overview of Internet of Things, architectures, and vital technologies and their usages in our daily life. However, this manuscript will give good comprehensions for the new researches, who want to do research in this field of Internet of Things

(Technology GOD) and facilitate knowledge accumulation in efficiently. The most profound technologies are those disappear. They weave themselves into the fabric of everyday life until they are indistinguishable from it was Mark Weiser’s central statement in his seminal paper [Weis 91] in Scientific America in 1991. There is a sea in humans’s daily life as well as in working conditions in organizations after the arrival of IT and ITeS technologies. This is becoming well-known concept across many horizontal and vertical markets including a common man’s everyday life in the society, as it has several applications.

The development of the Internet of Things [IOT] has been primarily driven by needs of large corporations that stand to benefit greatly from the foresight and predictability afforded by the ability to follow all objects through the commodity chains in which they are embedded. The ability to code and track objects has followed companies to become more efficient, speed up process, reduce error, prevent theft, and incorporate complex and flexible organizational systems through IOT. The IOT is a technological revolution that represents the future of computing and communications, and its development depends on dynamic technical innovation in a number of important fields, from wireless sensors to nanotechnology. The internet of things is a novel paradigm shift in IT arena. The phrase “internet of things” which is shortly known as IOT is coined from two words i.e., the first word is “internet” and the second word is “things”. the internet is a global system of interconnected computer networks that use

the standard internet protocol suite (TCP/IP) to serve billions of users worldwide. It is a network of networks that consists of millions global scopes, that are linked by broad array of electronic, wireless and optical networking technologies. Today more than 100 countries are linked into exchanges of data, news and opinions through internet. According to internet world statistics, as of December 31, 2011 there was an estimated 2,267,233,742 internet users worldwide (accessed data dated on 06/06/2013) from the universal resource location

### 3. PROPOSED SYSTEM

Wi-Fi module acts as router and provides internet connection and is used to monitor the status of the devices. Here the commands which we send are AT(Attention) commands. When power supply is ON, blue LED blinks which indicate the functioning of the system.

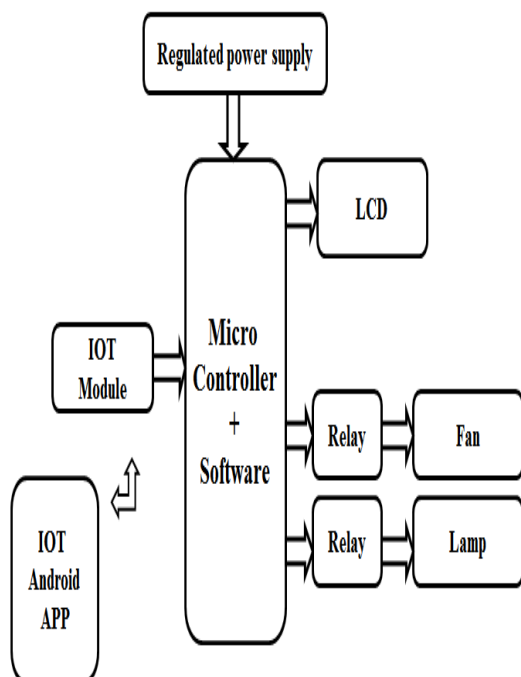

Fig. 1: Block Diagram using Microcontroller.

Whenever the system is ON the following are displayed in the LCD:

- IOT based home automation
- Initialising
- System ready

When it displays “System ready” then user is allowed to send SMS. In this project we are controlling three devices

- Device 1-Light
- Device 2-Buzzer
- Device 3-Fan.

1. Received message from-Mobile number
2. dev1on/dev2on/dev3on/dev1off/dev2off/dev3off

The messages we send should be of lowercase and no spaces are given. For example, we send dev1on then light is going to ON and same for the remaining devices. Status, of the devices can be monitored by following the below steps:

- Activate the Wi-Fi in the mobile
- Connect Wi-Fi to “project”
- Open Google
- Type 192.168.4.1 in the URL
- Then automatically it shows the status of the devices.
- 192.168.4.1 is the IP address of this system.

## 4. RESULTS

### 4.1 Arduino IDE

#### What is Arduino IDE?

The Arduino Integrated Development Environment - or Arduino Software (IDE)

- contains a text editor for writing code, a message area, a text console, a toolbar with buttons for common functions and a series of menus. It connects to the Arduino hardware to upload programs and communicate with them.

A program for Arduino hardware may be written in any programming language with compilers that produce binary machine code for the target processor. Atmel provides a development environment for their 8-bit AVR and 32-bit ARM Cortex-M based microcontrollers: AVR Studio (older) and Atmel Studio (newer).

## 4.2 Schematic diagram

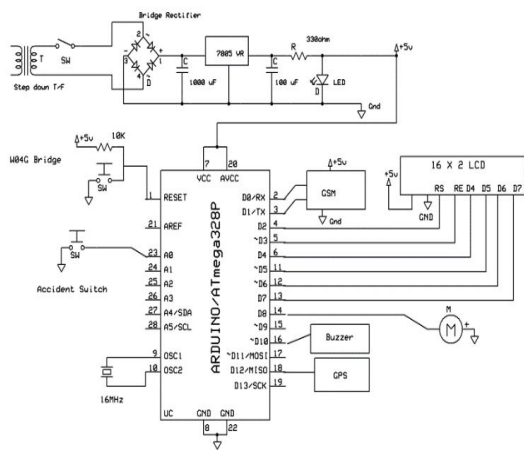

Fig. 2: Schematic diagram of proposed system.

## 4.3 Hardware implementation

The project “**IOT based home automation**” was designed such that any device of electrical home appliances at homes can be operated through webpage. The controlling of electrical appliances is done wirelessly through Wi-Fi.



## 5. CONCLUSION

Hence, “**IOT Based Home Automation**” is Integrating features of all the hardware components used have been developed in it. Advanced micro controller is used in it. Multiple electronic devices can be controlled and status of those devices can be monitored through internet.

### Future Scope

Our project “**IOT Based Home Automation**” is mainly intended to control the electrical home appliances using. IOT. This project has a IOT module, a 4-relay board to connect the home electrical appliances which are interfaced to the micro controller. The Micro Controller is programmed in such a way that depending on the received data from the phone the devices are operated that will be switched

ON/OFF automatically based on the input received by the IOT module. This project can be extended by adding GSM technology. GSM module can be used to get SMS alert about the status of the appliances of multiple devices like lights, fans, coolers...etc. Raspberry Pi can be included. Video monitoring can be included.

## REFERENCES

- [1] Shrikanthan N. Tan F Karande A., "Bluetooth Based Home Automation" , Microprocessors Micro systems, Elsevier Science, B.V. vol.26,no.6, pp281-289,(2009)
- [2] Piyare R., Tazil M., "Bluetooth based Home automation system using Cell Phone". Consumer Electronics,IEEE 15th International Symposium on, vol.45, no.3, pp.192-195(2011).
- [3] EASAMBATTU, Thejaswini; REDDY, P. Ajay Kumar; RAMAIAH, G.N. Kodanda. Controlling home appliances through GSM modem and Internet. International journal of Electronics Engineering Research, [S.I.], p. 1-7, oct 2013.
- [4] P. Magrassi, T. Berg, "A World of Smart Objects", Gartner research report R-17-2243,12 August 2002.
- [5] White Paper: "Internet of Things Strategic Research Roadmap", Antoine de Saint-Exupery, 15 sep 2009.
- [6] Souza, Alberto M.C. Amazonas, Jose R.A. "A Novel Smart Home Application Using an Internet of Things Middleware", Proceedings of 2013 European Conference on Smart Objects, Systems and Technologies (SmartSysTech), pp. 1 – 7, June 2013.
- [7] Perumal, T, Ramli, A.R, Chui Yew Leong, "Design and implementation of SOAP based residential management for smart home systems", IEEE Transactions on
- [8] Ming Wang, Guiqing Zhang, Chenghui Zhang, Jianbin Zhang, Chengdong Li. "An IoT-based appliance control system for smart homes", Fourth International
- [9] Conference on Intelligent Control and Information Processing (ICICIP), pp. 744 – 747, June 2013.
- [10] Yepeng Ni, Fang Miao, Jianbo Liu, Jianping Chai. "Implementation of Wireless Gateway for Smart Home", Communications and Network, pp. 16- 20,2013.
- [11] Kelly, S.D.T., Suryadevara, N.K.; Mukhopadhyay, S.C. "Towards the Implementation of IoT for Environmental Condition Monitoring in Homes", Sensors Journal, IEEE, Volume: 13, pp-3846 –3853, May 2013.