



COPY RIGHT

2017 IJIEMR. Personal use of this material is permitted. Permission from IJIEMR must be obtained for all other uses, in any current or future media, including reprinting/republishing this material for advertising or promotional purposes, creating new collective works, for resale or redistribution to servers or lists, or reuse of any copyrighted component of this work in other works. No Reprint should be done to this paper, all copy right is authenticated to Paper Authors

IJIEMR Transactions, online available on 12th June 2017. Link :

<http://www.ijiemr.org/downloads.php?vol=Volume-6&issue=ISSUE-4>

Title: Controlling Voltage With Electric Spring And Statcom.

Volume 06, Issue 04, Page No: 878 – 884.

Paper Authors

***DR BHASKAR KANNA, **PARVEEN KUMAR.**



USE THIS BARCODE TO ACCESS YOUR ONLINE PAPER

To Secure Your Paper As Per **UGC Guidelines** We Are Providing A Electronic Bar Code

CONTROLLING VOLTAGE WITH ELECTRIC SPRING AND STATCOM

***DR BHASKAR KANNA, **PARVEEN KUMAR**

*Phd, Associate Professor EEE Department, JNTUH College Of Engineering, Hyderabad.

**ISDS, Bsc (ET),MIE,MBA, PGDFS,CE (I),DFL (French)

Assistant Director Of Training, Directorate General Of Training, MSDE, NEW DELHI

ABSTRACT

With the increase in adoption of renewable energy sources into power grids, the issue of voltage and frequency fluctuation of the network becomes a crucial issue that needs to be resolved urgently. The Demand-side management (DSM) of power system provides the opportunity for the prospective grids to intelligently balance the power supply and consumption. As one of the crucial roles of DSM, smart loads are naturally committed to manage the power flow of the network. Other than previous communication-based smart loads, the recently proposed electric springs (ES) provide an opportunity to turn some conventional loads into smart loads without the need for communication. In this paper, a comparison is made between voltage control using ES against the STATic Compensator (STATCOM). A three bus system with electric spring and with STATCOM has been simulated in Matlab/Simulink environment for comparison

Keywords: Demand response, electric springs (ES), STATicCOMpensator (STATCOM), voltage control, voltage regulation

INTRODUCTION

The impending energy crisis and environmental issues require that substantial renewable energy sources should be included in the future as either centralized power mills or distributed generators. Due to the dynamically changing nature of renewable energy sources, this foreseeable major change in power grid demands sophisticated control methodologies and a new discipline of management strategies. Smart grids based on modern power electronics and telecommunication technologies have been proposed as a promising solution. To cope with the variability and uncertainty of renewable energy sources, new methods for load management are required. Voltage control in medium voltage (MV) or low voltage(LV) distribution networks is typically exercised through transformer tap-changers and/or switched capacitors/reactors. Sometimes a STATic Compensator (STATCOM) is used for fast and precise voltage regulation, especially for the sensitive/critical loads [1] The novel concept of electric spring (ES) has been proposed as an

effective means of distributed voltage control [2]. Among various methods for load management, the electric spring (ES), which is based on power electronics technology, can instantaneously balance the power consumption and generation. This technique has the advantage over existing demand side management [1]-[6] and energy storage solutions [7], [8] in that: i) it can control the load to reduce the fluctuation of the generator; ii) it can flatten the voltage fluctuation caused by unstable power generation in real time [9]. The first generation of ES is presented in [9]. Based on Hooke's law, the ES can handle reactive power to stabilize line voltage for critical loads. Research in [10] also shows that ES can reduce the capacity of energy storage by up to 50%.

In this paper, the focus is to compare the effectiveness of single point voltage control using STATCOM against voltage control using Electric Spring. A three bus system with electric spring and STATCOM has been simulated for the comparison.

2. FUNDAMENTAL PRINCIPLES AND CONTROL STRATEGIES OF STATCOM AND ES

STATCOM, also called Static Var Generator (SVG) or Advanced Static Var Generator (ASVG) is a rapidly developed and widely used reactive power compensation device using self-commutation variable current circuit. By adjusting the amplitude and the phase of AC-side voltage of inverter, it can compensate both inductive and capacitive reactive power continuously. Besides, STATCOM is competent for inhibiting negative sequence reactive current caused by unbalanced load, stabilizing abrupt change of voltage and eliminating harmonic current.

Currently, the basic configurations of STATCOM fall into two categories, namely voltage bridge topological structure and current bridge topological structure, as shown in Fig. 1.

STATCOM with voltage bridge topological structure has higher efficiency and lower failure rate comparing with STATCOM with current bridge topological structure. In consequence, the former form STATCOM is used more widely in practical engineering applications. Therefore, STATCOM with voltage bridge topological structure is selected to be researched and analyzed in this paper. By controlling power electronics to turn on or off, STATCOM converts DC voltage of DC-side to AC voltage with grid frequency voltage and connects to the grid through reactors. So STATCOM can be represented by an inverter voltage source of which the amplitude and the phase are controllable. The basic operation principle is illustrated through equivalent circuit and vector graphics in Fig. 2 (single phase, circuit losses ignored).

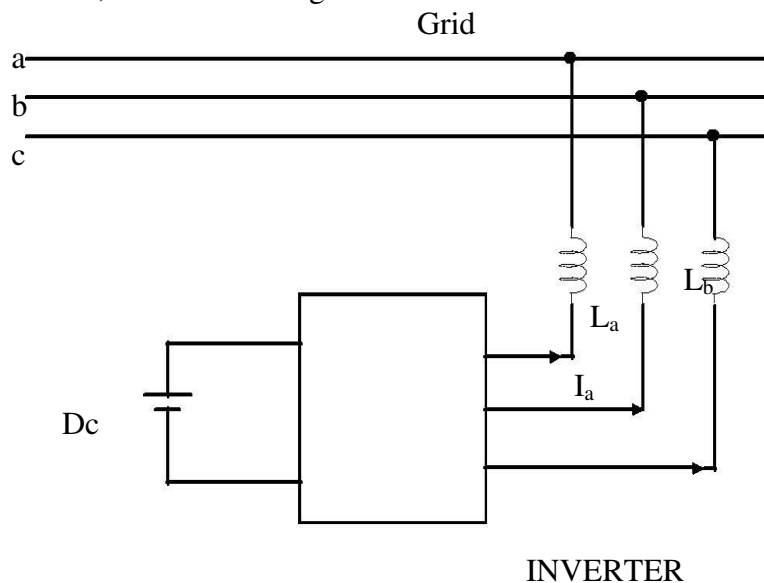

Fig. 1: Voltage bridge topological structure

By controlling power electronics to turn on or off, STATCOM converts DC voltage of DC-side to AC voltage with grid frequency voltage and connects to the grid through reactors. So STATCOM can be represented by an inverter voltage source of which the amplitude and the phase are controllable. The basic operation principle is illustrated through and UPFC technologies which handle

equivalent circuit and vector graphics in Fig. 2. Here is the grid phase rms and is STATCOM output rms voltage of AC-side. X stands for reactor connecting to grid. Electric spring in fact is a special form of reactive controller with input voltage control instead of the traditional output voltage control. Unlike STATCOM, Static Var Compensation (SVC) pure reactive power, the electric spring is a new

compensate both reactive power and) [2,12].

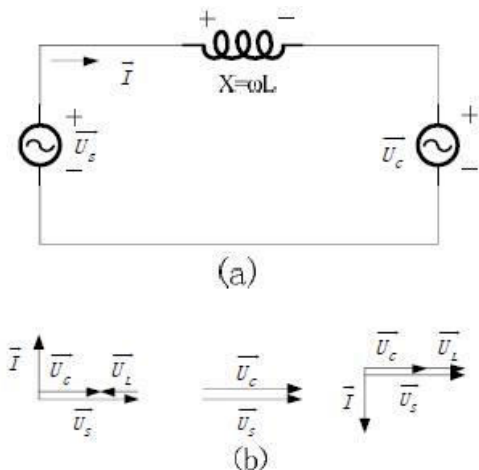

Fig. 2 (a) Equivalent circuit of single phase STATCOM. (b) Vector graphics of equivalent circuit

it could contribute to frequency control by modulating the voltage and hence the power consumed by the non-critical load while regulating the voltage across the critical loads. The non-critical loads are connected in series with the ES to form a smart load as shown in fig 3.

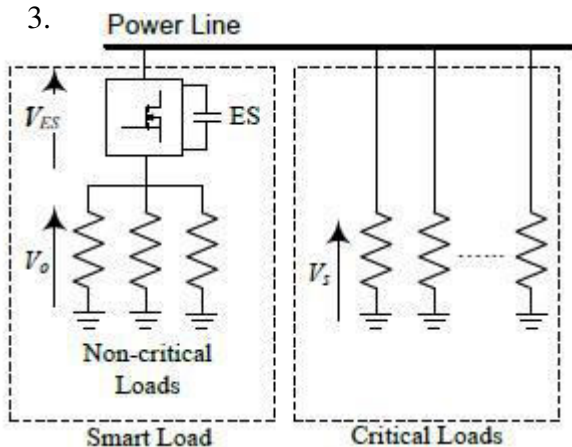

Fig. 3: Smart loads and critical loads in future smart grids

For reactive power control, an electric spring (ES) injects a compensation voltage in quadrature with the current through it. The current I_o can either lead the voltage by 90° , (capacitive mode for voltage support) or lag 90° (inductive mode for voltage suppression). The power converter circuit of the ES could simply be a two-level inverter as shown in Fig. 4. Thus, an ES can inject both inductive and

active (the energy storing devices like batteries). One potential advantage of the proposed capacitive reactive power to the power line similar to the conventional reactive power controller (RPC). For ease of understanding, both the critical and non-critical loads are assumed to be purely resistive although the underlying principle is still applicable as long as these loads are voltage dependent. Under this assumption, the phasor diagrams for inductive and capacitive modes of operation are shown in Fig. 5. The electric spring differentiates itself from a traditional RPC by adopting an “input-voltage control”. By regulating the input voltage V_s and letting the output voltage V_o to fluctuate dynamically (i.e. a new input-voltage control), an ES would (i) provide voltage support and (ii) simultaneously modulate the non-critical load power to follow the power generated. Such a subtle change in the control strategy of a traditional RPC from output control to input control offers new possibility of simultaneous voltage and frequency control enabling effective demand side management

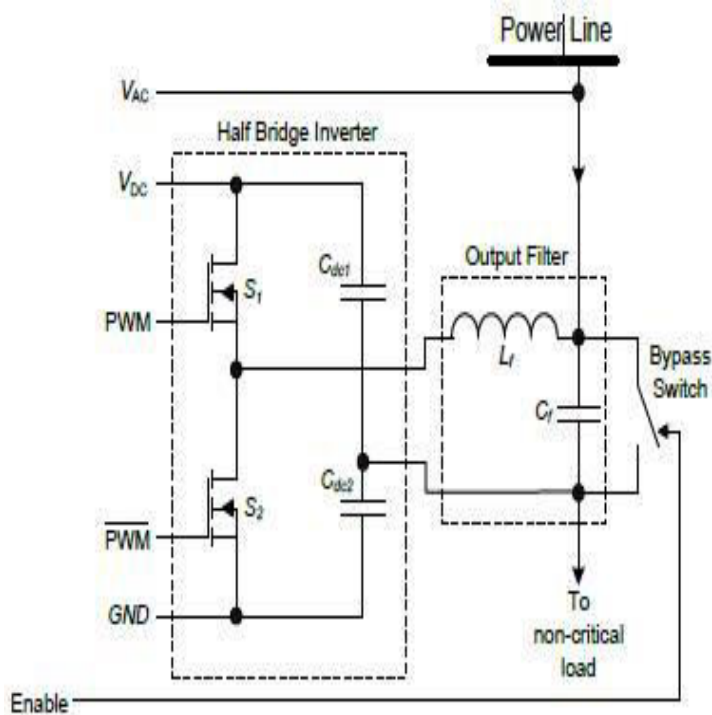

Fig. 4: Schematic of a single phase half bridge power inverter

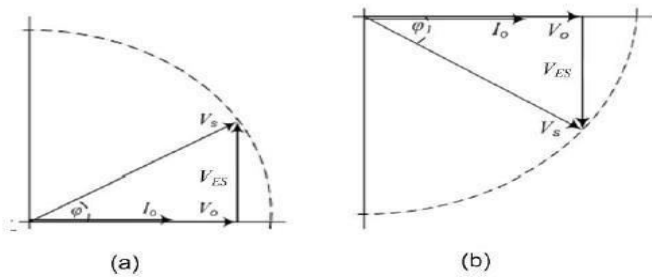

Fig. 5: Phasor diagrams for inductive and capacitive modes of operation of an ES

4. CONTROL OF ELECTRIC SPRINGS

Fig. 6 shows a complete control block diagram of an electric spring. It consists of two closed loop controller including an AC voltage controller to regulate the power line voltage and a DC bus voltage controller to regulate the inverter dc bus voltage. The individual transfer function of the digital PI controller in discrete form is expressed as

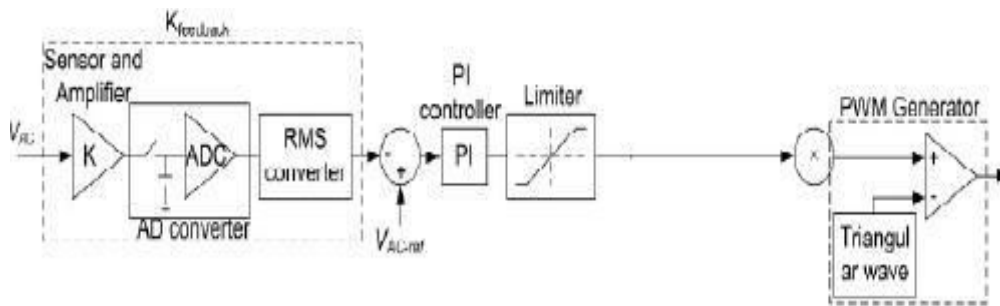

Fig. 6: Block diagram for electric spring control

The output of the PI compensator driving the AC line voltage error to zero decides the modulation index. The DC link voltage controller decides the phase angle of the injected voltage. When the angle of the reference sinusoidal voltage is measured with respect to the system current flowing through the non-critical voltage, it is going to be very close to 90 degrees. The deviation from 90 degree phase angle is decided by the real power exchange with the DC bus.

5. SIMULATION

5.1 Test System

In order to compare the voltage regulation performance of a single ES against that of a STATCOM, a simple test system as shown in Fig.7 has been considered. It comprises of a power source acting as the main power grid and a separate controllable power source to emulate an intermittent renewable source

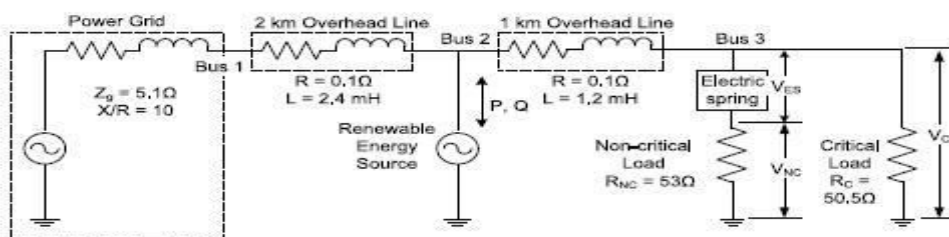

Fig. 7: Simulation set-up with an intermittent source and an equivalent power grid.

The controllable source is capable of injecting variable active and/or reactive power which

causes the voltage across the C load to fluctuate. For simplicity both C and NC loads are

represented by resistors although they do not have to be necessarily resistive. The above system is modeled in MATLAB/SIMULINK using a controllable voltage source representation for both ES and STATCOM. Modeling and control of ES is discussed in [14]. The magnitude of the controllable voltage representing the ES is controlled using a PI controller to minimize the difference between the actual and reference values of the voltage across the C load. Phase angle of the voltage

source is locked in quadrature to the phase angle of series current to ensure there is no active power transfer. The STATCOM is modeled by a controllable voltage source in series with impedance. Its control circuit is very similar to that of ES except for the adjustments due to its parallel connection to the C and NC load.

5.2 Three Bus system with No control

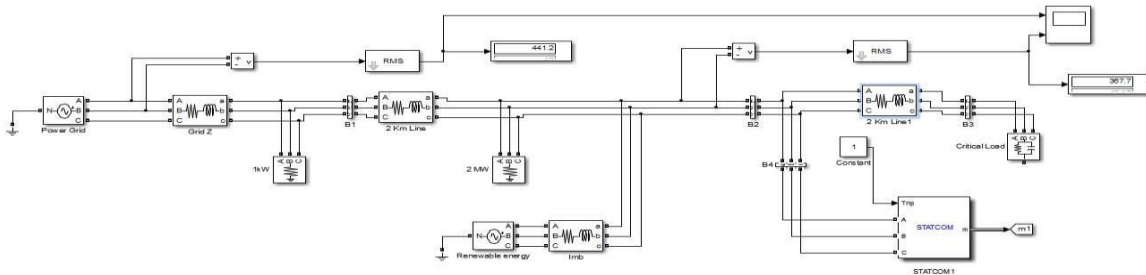

Fig 8: Three bus system without any control

A three bus system with no control circuit for voltage regulation is given in the figure.

The renewable source voltage is been fluctuated so that the voltage across the critical load. The

waveforms of grid voltage, renewable energy source voltage and load voltage respectively are given below in the figure 9.

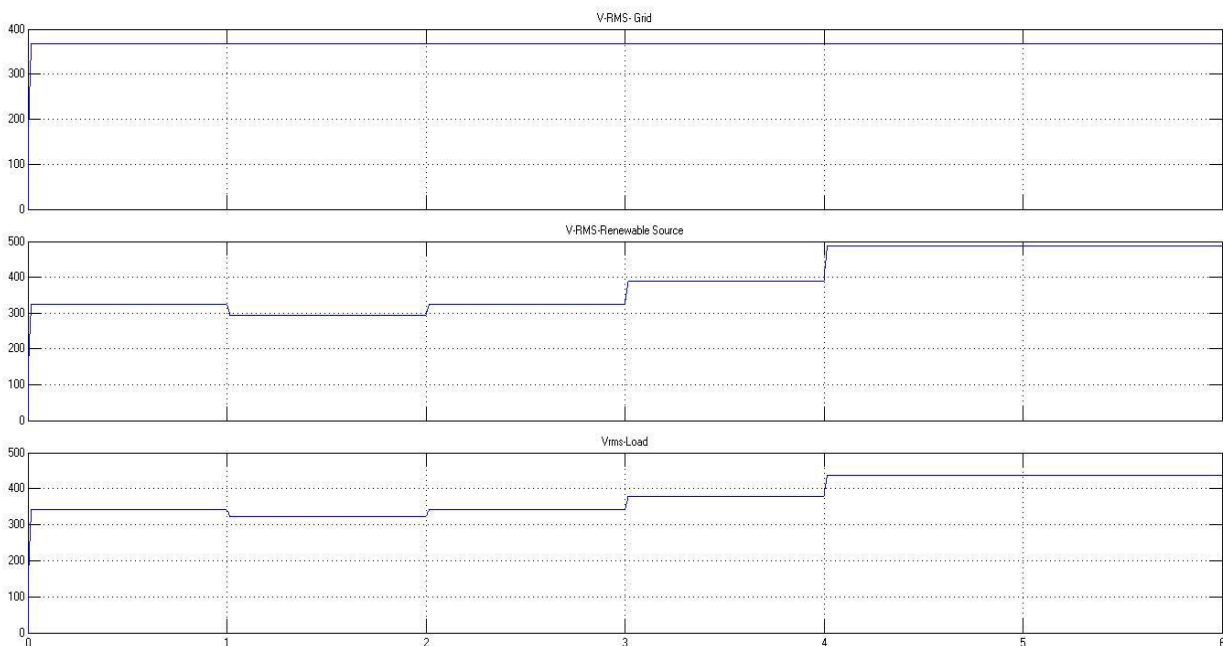
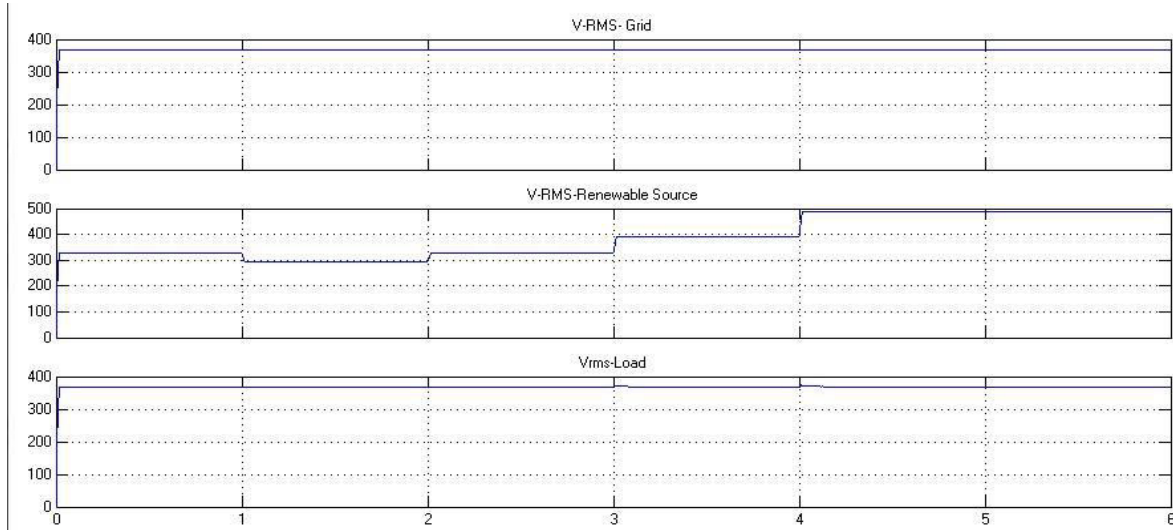

Figure 9: Waveforms with out any control

5.4 Three bus system with STATCOM



With STATCOM the voltage across critical load is been regulated when there is fluctuations in the renewable source voltage. Fig 10 shows waveforms with STATCOM.

6. CONCLUSION

In this paper, a comparison is made between voltage control using ES against the traditional single point control with STATCOM. For a given range of supply voltage variation, the total voltage regulation, and the total reactive capacity required for each option to produce the desired voltage regulation at the point of connection are compared. A simple case study with a single ES and STATCOM is presented first to show that the ES and STATCOM require comparable reactive power to achieve similar voltage regulation.

REFERENCES

- [1] N. G. Hingorani and L. Gyugyi, *Understanding FACTS: Concepts and Technology of Flexible AC Transmission Systems*. Piscataway, NJ, USA: IEEE Press, 2000.
- [2] S. Y. R. Hui, C. K. Lee, and F. F. Wu, "Electric springs - a new smart grid technology," *IEEE Transactions on Smart Grid*, vol. 3, no. 3, Sep. 2012.
- [3] M. Parvania and M. Fotuhi-Firuzabad, "Demand response scheduling by stochastic SCUC," *IEEE Transactions on Smart Grid*, vol. 1, no. 1, pp. 89–98, Jun. 2010.
- [4] M. Pedrasa, T. D. Spooner, and I. F. MacGill, "Scheduling of demand side resources using binary particle swarm optimization," *IEEE Transactions on Power Systems*, vol. 24, no. 3, pp. 1173–1181, Aug. 2009.
- [5] A. J. Conejo, J. M. Morales, and L. Baringo, "Real-time demand response model," *IEEE Transactions on Smart Grid*, vol. 1, no. 3, pp. 236–242, Dec. 2010.
- [6] A. J. Roscoe and G. Ault, "Supporting high penetrations of renewable generation via implementation of real-time electricity pricing and demand response," *IET Renewable Power Generation*, vol. 4, no. 4, pp. 369–382, Jul. 2010.
- [7] P. Palensky and D. Dietrich, "Demand side management: demand response, intelligent energy systems, and smart loads," *IEEE Transactions on Industrial Informatics*, vol. 7, no. 3, pp. 381–388, Aug. 2011.
- [8] A. Mohsenian-Rad, V. W. S. Wong, J. Jatskevich, R. Schober, and A. Leon-Garcia, "Autonomous demand-side management based on game theoretic energy consumption scheduling for the future smart grid," *IEEE Transactions on Smart Grid*, vol. 1, no. 3, pp. 320–331, Dec. 2010.
- [9] A. Mohd, E. Ortjohann, and A. Schmelter, "Challenges in integrating distributed energy storage systems into future smart grid,"

- IEEE Symposium on Industrial Electronics, pp. 1627-1632, 2008
- [10] J. A. McDowall, "Status and outlook of the energy storage market," PES 2007, Tampa, July 2007.
- [11] C. K. Lee, Hui, and S. Y. R. Hui, "Reduction of energy storage requirements in future smart grid using electric springs," IEEE Transaction on Smart Grid, vol. , no. 99, pp. 1-7, Apr. 2013.
- [12] C.K. Lee, K.L. Cheng and Wai Man Ng, "Load characterisation of electric spring," Energy Conversion Congress and Exposition, pp. 4665-4670, 2013.
- [13] S.C. Tan, C.K. Lee and S.Y.R. Hui, "General steady-state analysis and control principle of electric springs with active and reactive power compensations," IEEE Transactions on Power Electronics. vol. 28. pp. 3958-3969, August 2013.
- [14] N. R. Chaudhuri, C. K. Lee, B. Chaudhuri, and S. Y. R. Hui, "Dynamic modeling of electric springs," IEEE Trans. SmartGrid, to be published [Online]. Available:
<http://ieeexplore.ieee.org/stamp/stamp.jsp?tp=&arnumber=6873343>