



COPY RIGHT

2017 IJIEMR. Personal use of this material is permitted. Permission from IJIEMR must be obtained for all other uses, in any current or future media, including reprinting/republishing this material for advertising or promotional purposes, creating new collective works, for resale or redistribution to servers or lists, or reuse of any copyrighted component of this work in other works. No Reprint should be done to this paper, all copy right is authenticated to Paper Authors

IJIEMR Transactions, online available on 6th June 2017. Link :

<http://www.ijiemr.org/downloads.php?vol=Volume-6&issue=ISSUE-3>

Title: Design of A Simple Auxiliary Circuits With ZCS-PWM Full Bridge DC-DC Converter Fed Single Phase Induction Drive Applications

.

Volume 06, Issue 04, Pages: 669 – 673.

Paper Authors

***AKULA SAMBASIVA RAO, SM GAVASKAR MEDABALIMI.**

*Scholar Dept Of EEE, St.Mary's Group of Institution, Chebrol, Guntur.



USE THIS BARCODE TO ACCESS YOUR ONLINE PAPER

To Secure Your Paper As Per **UGC Guidelines** We Are Providing A Electronic Bar Code

Design of A Simple Auxiliary Circuits With ZCS-PWM Full Bridge DC-DC Converter Fed Single Phase Induction Drive Applications

¹AKULA SAMBASIVA RAO, ²SM GAVASKAR MEDABALIMI.

¹PG Scholar Dept Of EEE, St.Mary's Group of Institution, Chebrol, Guntur.

²Assistant Professor Dept Of EEE, St.Mary's Group of Institution, Chebrol, Guntur.

ABSTRACT: A new soft switching pulse-width-modulated (PWM) fly back dc/dc converter with a simple auxiliary circuit is proposed. This is achieved by using two very simple active auxiliary circuits one active, the other passive. The outstanding feature of the new converter is that it allows its main power switches to operate with zero current switching (ZCS) and with fewer conduction losses than conventional full-bridge converters. By adding this auxiliary circuit to the conventional pulse width modulation isolated fly back converter, all power semiconductor devices are soft switched. In addition, the proposed converter frequency is constant and has no additional current stress in the main switch in comparison with conventional ones. Simulation and experimental results justify the theoretical analysis.

1. INTRODUCTION

NEW techniques are proposed in order to decrease switching losses and to increase power density in dc-dc converters at high power and frequencies [1]–[4]. The applications of soft-switching methods are expanding. The most remarkable method in high-power isolated applications is Phase Shifted (PS) Zero Voltage Switching (ZVS) method, which provides all of the switches to operate with ZVS without any additional auxiliary switches. The parasitic capacitance energy is discharged by the leakage inductance, and the MOSFET turns on with zero voltage transition (ZVT). Insulated gate bipolar transistor (IGBT) is preferred over MOSFET at high voltage and high-power levels in industrial applications. Low RDSON MOSFETs are quite expensive compared to the IGBTs with equivalent current and voltage ratings. The choice of IGBT over MOSFET is mandatory due to non availability of high voltage and high-

current MOSFET devices in some applications. An external snubber capacitor is connected in parallel to each IGBT in order to decrease turn-off losses, in case the IGBT is used in the phase shifted full bridge (PSFB) pulse width modulation (PWM) converter [5]–[26]. When the ZVT condition is not provided at no load and at light loads, the parallel capacitors discharge through IGBT at turn on and this causes increase in switching losses and failure risk of the IGBTs. This condition causes problems at specially the lagging leg [5]–[26]. Capacitor discharge through IGBT restricts the use of high-value capacitor in parallel to IGBT. Therefore, the election of the parallel capacitor value is very important. The parallel snubber capacitor value should be selected according to the speed and the maximum current of the IGBT [5]. The performance of the converter decreases rapidly at high-current levels because of the turn-off switching losses.

At the leading leg, the required energy for discharging the parallel capacitor is supplied from the load current, so the use of high-value capacitor in the leading leg has no drawback. In PSFB PWM dc–dc converters, some problems arise such as variation of duty cycle with load current, hard switching because of insufficient energy in leakage inductance at light loads, and high-voltage peaks and oscillations at the output diodes, and increment in the conduction losses because of the primary current flowing in the freewheeling interval. It is possible to encounter many studies in the literature about these converters and solution for the problems [5]–[26].

II. CIRCUIT DIAGRAM

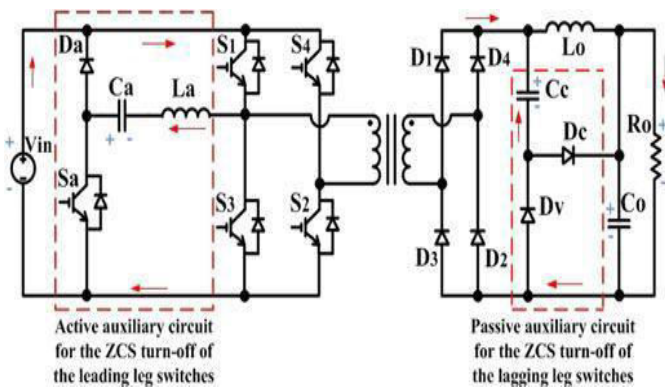

Fig. 1. Circuit Diagram of Dc-Dc Converter

A new ZCS-PWM full-bridge converter is proposed in this paper. The outstanding feature of the new converter is that it allows its main power switches to operate with ZCS and with fewer conduction losses than conventional full-bridge converters. This is achieved by using two very simple active auxiliary circuits—one active with a switch that can turn on and off with ZCS and one passive that consists of a few passive components. The paper presents the new converter and then discusses its operation, steady-state

characteristics and design. Experimental results obtained from a converter prototype are presented to validate the converter's performance and the concepts presented in the paper. A new ZCS-PsWM full-bridge converter is proposed in this paper. The outstanding feature of the new converter is that it allows its main power switches to operate with ZCS and with fewer conduction losses than conventional full-bridge converters. This is achieved by using two very simple active auxiliary circuits—one active with a switch that can turn on and off with ZCS and one passive that consists of a few passive components. The paper presents the new converter and then discusses its operation, steady-state characteristics and design. Experimental results obtained from a converter prototype are presented to validate the converter's performance and the concepts presented in the paper.

III. CONVERTER OPERATION

The proposed converter is shown in Fig. 1. It operates like a ZVZCS-PWM converter except that the auxiliary circuit is activated whenever the main power switches in the leading leg to which it is attached are about to turn off. It should be noted that in this diagram, as in other circuit diagrams present in this paper, the transformer leakage inductance is not shown as a separate element, but is assumed to be a part of the transformer. Equivalent circuit diagrams of the modes of operation that the proposed converter goes through during a half switching are shown in Fig. 2 and ideal converter waveforms are shown in Fig. 3.

It should be noted that in Fig. 3, a current waveform such as I_{S1} shows the current flowing through a switch (positive part of the waveform) and its body diode (negative part of the waveform). Moreover, the I_{S_a} waveform is also the waveform for I_{L_a} and I_{C_a} as $I_{S_a} = I_{L_a} = I_{C_a}$ and V_{C_a}

on the V_{Ca} waveform can be considered to be equal to the input voltage. When the device is placed in sleep, Timer2 will not increment, and the state of the module will not change. If the CCP pin is driving a value, it will continue to drive that value. When the device wakes-up, it will continue from this state. In [7], an auxiliary circuit which includes two MOSFETs and a serial inductance is proposed. The inductance current is increased before the IGBT devices on the lagging leg are turned off. The ZVS conditions of the FB converter are improved, but the losses in the auxiliary circuit reduce the efficiency. The auxiliary circuit does not operate with soft switching. Main IGBTs are subjected to the current stress before turn off and this increases the switching losses in the turn-off process. The proposed method is not preferred due to low efficiency, high cost, and control difficult.

IV. MAIN FEATURES AND DESIGN PROCEDURE

In this section, the design procedure of the proposed converter is given. The component values for implementing the converter are determined according to the design procedure. A Selection of the Boundary Current I_a . The boundary current level I_a . The proposed converter is shown in Fig. consists of a conventional PSFB PWM converter and an auxiliary circuit connected to the lagging leg. The auxiliary circuit contains two IGBTs with reverse recovery diodes and two capacitors $C1A, C2A$. At low output currents, converter operates as the conventional PSFB PWM converter. Low-valued snubber capacitors are connected at the lagging leg. These capacitors provide ZVS operation at light loads and improve the turn-off behavior of the IGBT until a current level. In the proposed converter, auxiliary circuit is operated only at high-output currents. By means of the auxiliary circuit, high value capacitors are connected to the lagging leg and the turnoff performance of the lagging leg switches is improved. The IGBTs used in the auxiliary circuit operate under soft-switching conditions. The conduction loss of the auxiliary switches is very low because they conduct current for a very short time. The operation of the auxiliary circuit starts when primary current I_P is larger than boundary current level I_a .

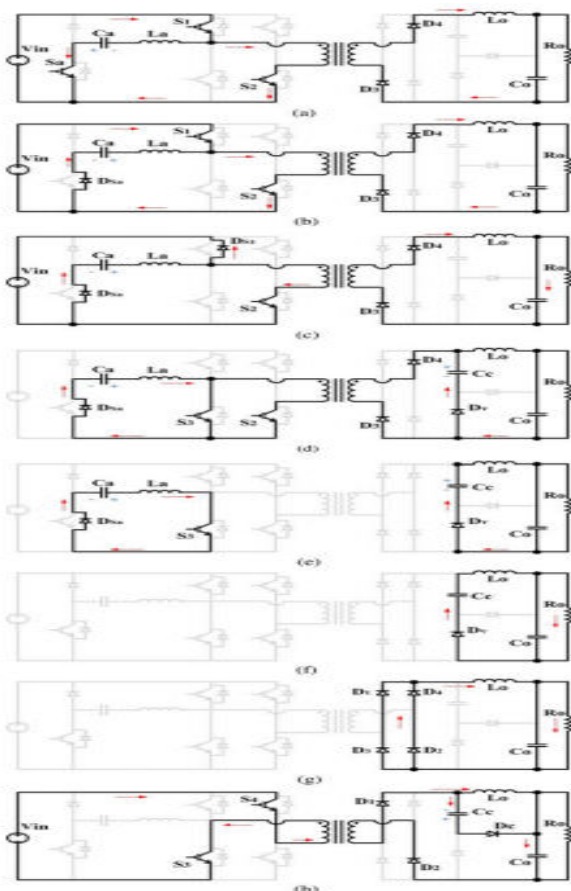

Fig. 2. Equivalent circuit for each mode of operation.

V. SIMULATION RESULTS

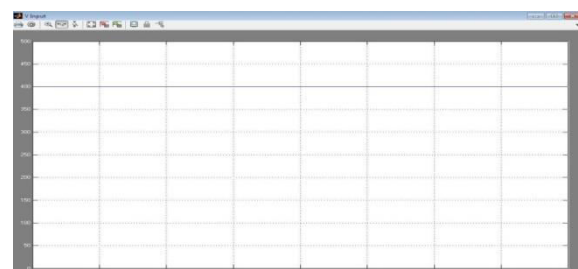

Fig. 4 Input Voltage

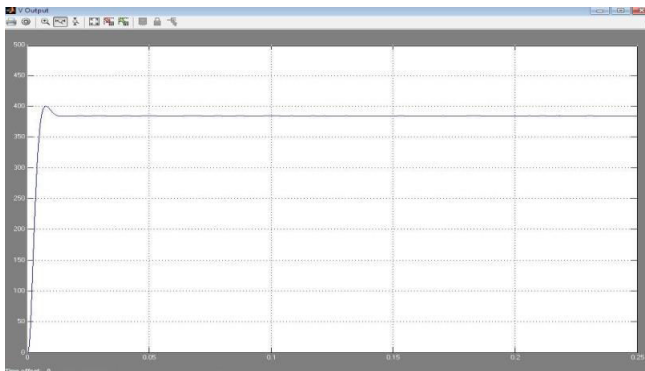

Fig .5 Output Voltage

VI.CONCLUSION

A new ZCS-PWM full-bridge converter is proposed in this paper. The outstanding feature of the new converter is that it allows its main power switches to operate with ZCS and with MOUSAVI AND MOSCHOPOULOS: NEW ZCS-PWM FULL-BRIDGE DC-DC CONVERTER WITH SIMPLE AUXILIARY CIRCUITS 1329 Fig..Efficiency comparison results.fewer conduction losses than conventional full-bridge converters. This is achieved by using a very simple active auxiliary circuit and a ZVZCS technique so that the converter has all the advantageous features of ZVZCS converters but with ZCS operation for all the converter switches so that they can all be IGBT devices, which helps reduce component cost. The proposed converter does not have the drawbacks of previously proposed techniques for higher power dc-dc full-bridge converters with IGBTs, including resonant techniques, ZCS-PWM techniques with active auxiliary circuits, passive techniques, ZVZCS techniques, and techniques that require the use of reverse blocking diodes. Experimental results obtained from a 3 kW, 80 kHz

converter prototype confirm the feasibility of the converter and show that the active auxiliary circuit results in a maximum efficiency improvement of 7% compared to the conventional ZVZCS converter due to the elimination of leading leg turn-off losses by the active auxiliary circuit

REFERENCES

- [1] C. Liu, B. Gu, J. Lai, M. Wang, C. Zheng, Y. Ji, and P. Sun, "High efficiency hybrid full-bridge-half-bridge converter with shared ZVS lagging leg and dual outputs in series," *IEEE Trans. Power Electron.*, vol. 28, no. 2, pp. 849–861, Feb. 2013.
- [2] K. Jin, Y. Sun, M. Xu, D. Sterk, and F.C. Lee, "Integrated magnetic self-driven ZVS nonisolated full-bridge converter," *IEEE Trans. Ind. Electron.*, vol. 57, no. 5, pp. 1615–1623, May 2010.
- [3] X. Zhang, W. Chen, X. Ruan, and K. Yao, "A novel ZVS PWM phase-shifted full-bridge converter with controlled auxiliary circuit," in *Proc. IEEE APEC*, Feb. 2009, pp. 1067–1072.
- [4] I. Lee and G. Moon, "Soft-switching dc/dc converter with a full ZVS range and reduced output filter for high-voltage applications," *IEEE Trans. Power Electronics*, vol. 28, no. 1, pp. 112–122, Jan. 2013.
- [5] W. Chen, X. Ruan, and J. Ge, "A novel full-bridge converter achieving ZVS over wide load range with a passive auxiliary circuit," in *Proc. IEEE ECCE*, Sep. 2010, pp. 1110–1115.
- [6] D. Sterk, M. Xu, and F.C. Lee, "High frequency ZVS self-driven full-bridge using full integration of magnetics," in *Proc. IEEE APEC*, 2010, pp. 1210–1216.
- [7] Z. Chen, M. Chen, F. Ji, and J. Li, "Analysis and implementation of a novel full-bridge ZVS converter with adaptive auxiliary circuit," in *Proc. IEEE*

IECON, Nov. 2010, pp. 358–363.

[8] H. L. Do, “Improved ZVS Dc–dc converter with a high voltage gain and a ripple-free input current,” *IEEE Trans. Circuits Syst.*, vol. 59, no. 4, pp. 846–853, Apr. 2012.

[9] J. Sun, X. Ding, M. Nakaoka, and H. Takano, “A novel series resonant ZCS full bridge three-level dc–ac inverter,” in *Proc. IEEE APEC*, 2008, pp. 419–425.

[10] W. Huai, S. Qian, H. Chung, S. Tapuchi, and A. Ioinovici, “Series resonant ZCS-PFM DC–DC converter with multistage rectified voltage multiplier

and dual-mode PFM control scheme for medical-use high-voltage X-ray power generator,” *IEEE Trans. Electric Power Appl.*, vol. 147, no. 6, pp. 527–534, Aug. 2000.

[11] W. Chen, Y. Gu, and Z. Lu, “A novel three Level full bridge resonant dc–dc converter suitable for high power wide range input applications,” in *Proc. IEEE APEC*, Feb./Mar. 2007, pp. 373–379.

[12] M.S. Agami and P. Jain, “A new full bridge three level resonant single stage AC/DC converter,” in *Proc. IEEE PESC*, Jun. 2007, pp. 2699–2704.

[13] W. Huai, S. Qian, H. Chung, S. Tapuchi, and A. Ioinovici, “A ZCS currentfed full-bridgePWMconverter with self-adaptable soft-switching snubber

energy,” *IEEE Trans. Power Electron.*, vol. 24, no. 8, pp. 1977–1991, Aug. 2009.

[14] K. Fathy, T. Doi, K. Morimoto, H. Lee, and M. Nakaoka, “A novel soft-switching PWM full-bridge DC/DC converter with DC busline series switch-parallel capacitor edge resonant snubber assisted by highfrequency transformer leakage inductor,” in *Proc. IEEE IPERC*, 9-324. ISSN: 2229-6956(Online)

Aug. 2006, pp. 1–5.

[15] K. Suzuoka, S. Moisseev, L. Gamage, K. Soshin, K. Nishida, and M. Nakaoka, “Boost transformer linked full bridge soft-commutation DC–DC power converter with secondary-side phase-shifted PWM rectifier switches,” in *Proc. IEEE IECON*, Nov. 2003, pp. 49–54.

[16] K. Jin and X. Ruan, “Hybrid full-bridge three-level LLC resonant converter—A novel DC–DC converter suitable for fuel-cell power system,” *IEEE Trans. Ind. Electron.*, vol. 53, no. 5, pp. 1492–1503, Oct. 2006.

[17] X. Sun, J. Liu, X. Jin, and W. Wu, “High power high frequency zero current transition full bridge DC/DC converter,” in *Proc. IEEE APEC*, Feb. 1998, pp. 823–828.

[18] Muruganandam, M. and Madheswaran, M. “Stability Analysis and Implementation of Chopper fed DC Series Motor with Hybrid PID-ANN Controller” Published in *International Journal of Control, Automation and Systems*, Springer, Volume 11, Issue 5, October 2013. ISSN: 1598-6446 (Print) 2005-4092 (Online)

[19] M. Muruganandam, M. Madheswaran, “Experimental verification of chopper fed DC series motor with ANN controller” Published in *International Journal of Frontiers of Electrical and Electronic Engineering in China*, (Springer Publication) Volume 7, Issue 4, December 2012, pp 477-489. ISSN: 2095-2732 (print) 1673-3584 (Online)

[20] M. Madheswaran and M. Muruganandam, “Simulation and Implementation of PID-ANN Controller for Chopper Fed Embedded PMDC Motor” Published in *ICTACT Journal On Soft Computing*, Volume 2, Issue 3, April 2012 pp 31