



International Journal for Innovative Engineering and Management Research

A Peer Reviewed Open Access International Journal

www.ijiemr.org

COPY RIGHT



ELSEVIER
SSRN

2022IJIEMR. Personal use of this material is permitted. Permission from IJIEMR must be obtained for all other uses, in any current or future media, including reprinting/republishing this material for advertising or promotional purposes, creating new collective works, for resale or redistribution to servers or lists, or reuse of any copyrighted component of this work in other works. No Reprint should be done to this paper, all copy right is authenticated to Paper Authors

IJIEMR Transactions, online available on 28th August 2022. Link

[:http://www.ijiemr.org/downloads.php?vol=Volume-11&issue=ISSUE-08](http://www.ijiemr.org/downloads.php?vol=Volume-11&issue=ISSUE-08)

DOI: 10.48047/IJIEMR/V11/ISSUE 08/27

Title **MODELING OF HYBRID PID-FUZZY CONTROLLER BASED INDUCTION MOTOR DRIVE FOR ELECTRIC VEHICLE APPLICATIONS**

Volume 11, Issue 08, Pages: 206-216

Paper Authors

Mr. Ch S K B Pradeep Kumar, Mrs. Ch. Sabitha, Ms. Ch K T S R Kowstubha, Ms. D Saiprasanthi, Mrs. B. Patrisamma



USE THIS BARCODE TO ACCESS YOUR ONLINE PAPER

To Secure Your Paper As Per **UGC Guidelines** We Are Providing A Electronic Bar Code

MODELING OF HYBRID PID-FUZZY CONTROLLER BASED INDUCTION MOTOR DRIVE FOR ELECTRIC VEHICLE APPLICATIONS

Mr. Ch S K B Pradeep Kumar, Assistant Professor, EEE Department, Ramachandra College of Engineering, Eluru
Mrs. Ch. Sabitha, Assistant Professor, EEE Department, Ramachandra College of Engineering, Eluru
Ms. Ch K T S R Kowstubha, Assistant Professor, EEE Department, Ramachandra College of Engineering, Eluru
Ms. D Saiprasanthi, Assistant Professor, EEE Department, Ramachandra College of Engineering, Eluru
Mrs. B. Patrisamma, Assistant Professor, EEE Department, Ramachandra College of Engineering, Eluru

ABSTRACT

In this paper the consumption and extraction cost of fossil fuels such as gasoline and diesel are very high. The major reason of the surplus usage of these fossil fuel based vehicle is that have enhanced the excavating of these conventional resources. The most important drawback is global warming caused by the burning of fossil fuels. The large amount of green house gases is emitted that causes pollution. There will be no fuel left for usage because of rise in demand for gasoline and diesel. So it's better to adapt for the electric vehicles rather than a traditional IC engine vehicles. The solar PV powered electric vehicles reduces the usage of fuel and pollution .It implementing the eco-friendly transportation in the world to build a green environment. Generally an electric vehicle uses a battery that is charged from a external power supply. But in solar PV modules are used to charge a battery by means of absorbing radiation from the sun and converting into electrical power by proposed method.

Electric vehicles are vastly used because of their advantages. Mostly Hybrid Electric Vehicles (HEV) are used because of the advantages of those vehicles i.e. runs with both conventional fuel and battery. For every vehicle we need control mechanism that is done by using PID controller. But PID controller did not give the better performance of the system in terms of speed regulation, error and integral absolute error.

Keywords: *Hybrid Electric Vehicles (HEV) , Electric vehicle, PV(Photo Voltaic), battery, fuzzy logic controller*

1. INTRODUCTION

Now days the population is drastically increased and because of this the transportation for these people creates a problem. In order to meet the transportation facilities to these people we need to produce the more vehicles but the major problem in production of these vehicles Department of EEE, RCE Page 3 is fuel. We are using the non-renewable resources for producing the fuels but If we use the vehicles with these fuels, these vehicles releases the more greenhouse gases and smoke. This may create lot of pollution to environment.

Hybrid electric vehicle means it having both gasoline and battery as sources for producing the power. It is different from conventional electric vehicle. In electric vehicle we can charge the battery and we can drive the vehicle up to the battery will be discharged. But in hybrid electric vehicle (HEV) whenever the battery is fully discharged we can run the vehicle through the gasoline or any other fuel. This is the main advantage of the hybrid electric vehicle and also in conventional electric vehicle we cannot charge the vehicle during its running but in case of hybrid electric vehicle we can charge the battery during the vehicle running condition also.

2.LITERATURE SURVEY

In 1769 the first steam powered vehicle was designed by Nicolas –Joseph steam powered vehicle were so heavy. In 1807, the next step towards the development of the car was the invention of the internal combustion engine. Robert Anderson develops the first crude electric vehicle in the year 1832. In 1899 EVs are popular compared to the gas-steam powered automobiles. EVs easy to drive did not emit pollutants. In 1901 inventors take a note of electric cars high demand, exploring ways to improve the technology. world first hybrid electric cars is invented so, it is called as golden age of EVs .In the year 1920 because of cheap cost of crude oil helps to decline electric vehicles. In future market may develop solar powered EVs .no fuel left for usage so its better to adapt for EVs rather than IC engine.

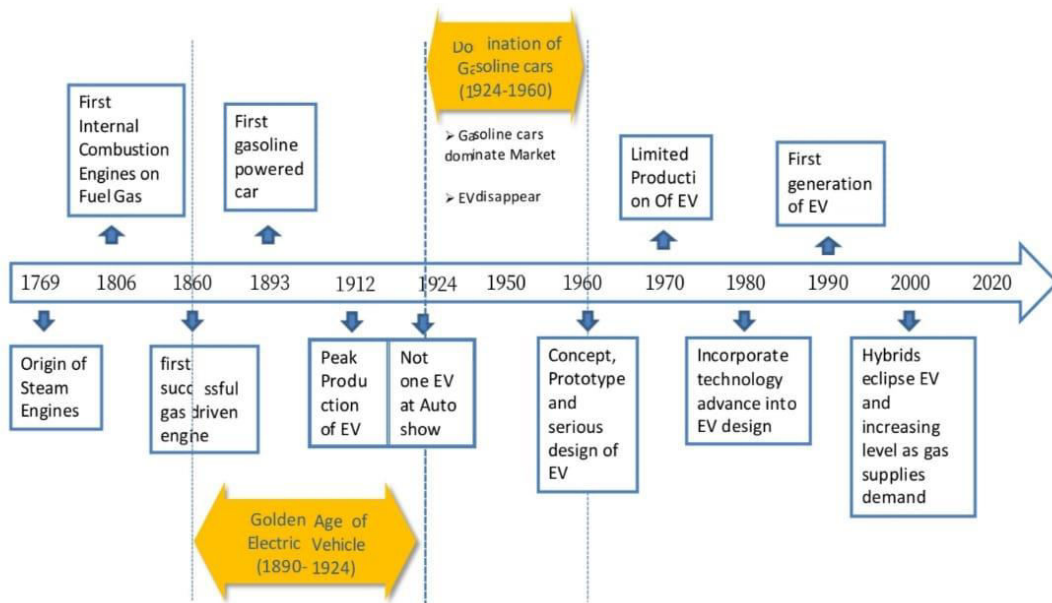

3. DESIGN OF HYBRID SPEED CONTROLLERS

An electric vehicle is a vehicle that is propelled by one or more electric motors, using energy stored in batteries. Compared to internal combustion engine (ICE) vehicles, electric vehicles are quieter, have no exhaust emissions, and lower emissions overall.

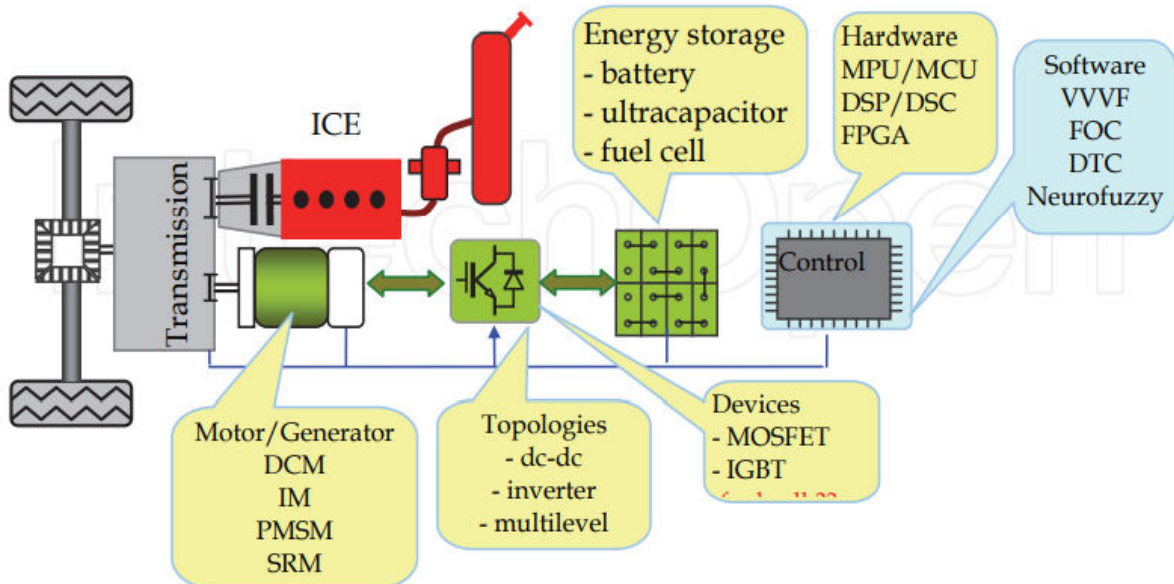

Figure 1: MAJOR COMPONENTS OF HYBRID ELECTRIC VEHICLE

Conventional Controller: Induction motor can be controlled with the help of conventional PI, PD, and PID controller with the use of indirect field oriented control technique. The conventional controller is a feedback controller. It calculates an error value as the difference between the measured process value and the desired set point value and then drives the controlled plant to keep the steady state error equal to zero.

3.1..PI Controller

Proportional-Integral, PI, controller is most widely adopted in industrial application due to its simple structure, easy to design and low cost. PI controller produces an output signal consist of a sum of error and the integral of that error. The error represents the difference between the desired motor speed and the actual motor speed.

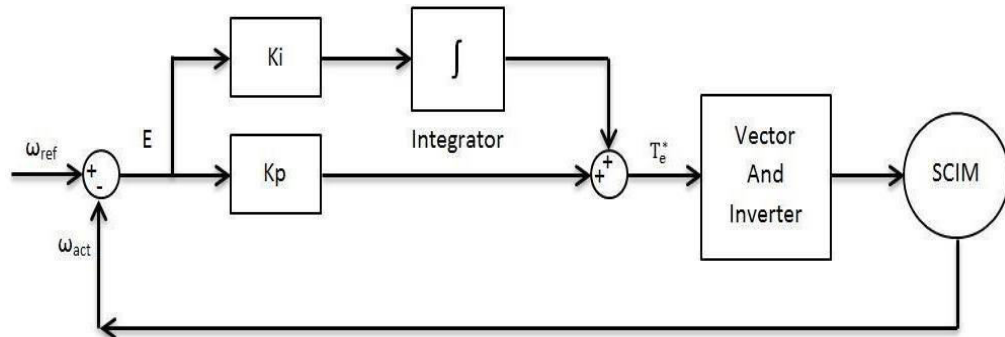

Figure 2: PI controller block diagram.

3.2.PD Controller

Proportional-Derivative, PD, controller has the ability to predict the future error of the system. Therefore, it uses to increase the stability of the system. The output of PD controller consists of a sum of two terms, the error signal and the derivative of that error.

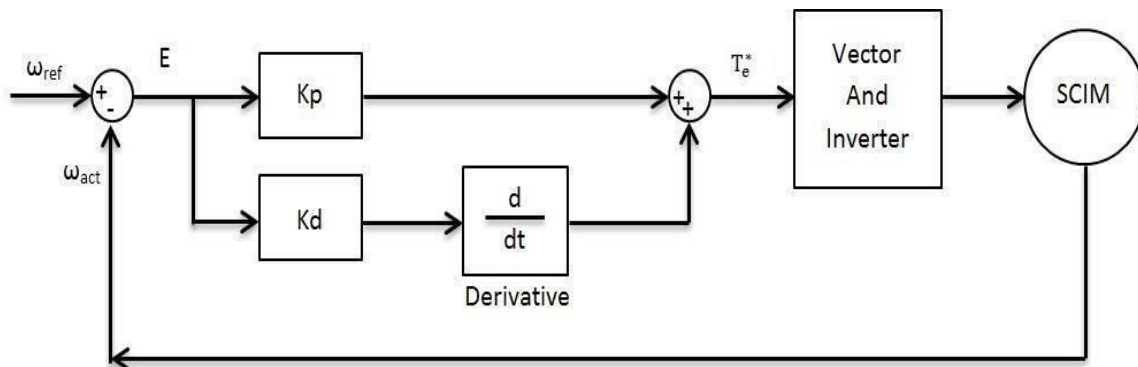

Figure 3: PD controller block diagram.

3.3..PID Controller

Proportional-Integral-Derivative, PID, controller is widely used in industrial control system. PID controller has all the necessary dynamics: fast reaction on change of the controller input (D controller), increase in control signal to lead error towards zero (I controller) and suitable action inside control error area to eliminate oscillations (P controller). Derivative mode improves stability of the system and enables increase in gain K_p , which increases speed of the controller response. The output of PID controller consists of three terms the error signal, the error integral and the error derivative. The error signal is computed by equation (3.2). Figure 3.3 shows the block diagram of PID controller.

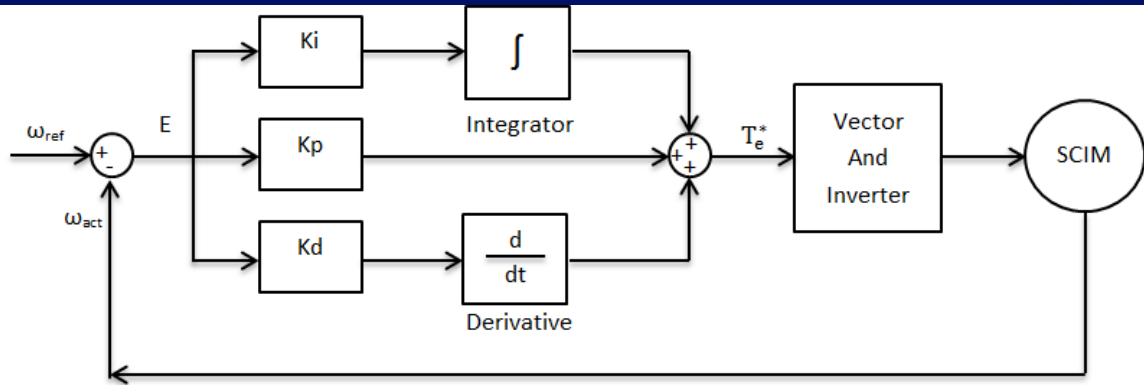

Figure 4: PID controller block diagram.

PID controller combines the advantage of proportional, derivative and integral controlaction. Table 1 shows the effect of gain coefficient on the system performance.

Table 1: The effects of gain coefficients on the performance of PID controller system

TYPE	RISE TIME	OVERSHOOT	SETTLING TIME	STEADY STATE ERROR
K_p	Decrease	Increase	Small change	Decrease
K_i	Decrease	Increase	Increase	Eliminate
K_d	Small change	Decrease	Decrease	Small change

3.4.Fuzzy Logic Controller

Fuzzy logic, FL, is another class of artificial intelligence. Its goal is planting human intelligence in a system so that the system can think intelligently like a human being .

Fuzzy logic techniques have been recognized in recent years as powerful tools for dealing with the modeling and control of complex systems for which no easy mathematical descriptions can be provided [3]. Fuzzy logic control is considered as a linguistic control strategy based on the use of if-then statement for the control process. In this statement, several variables that are expressed in natural English language such as positive, zero, and negative could be used either in antecedent (the if-part of the statement) or in consequent (the then-part of the statement). As a result, the mathematical model of the system is not required in fuzzy control so it can be applied to nonlinear systems.

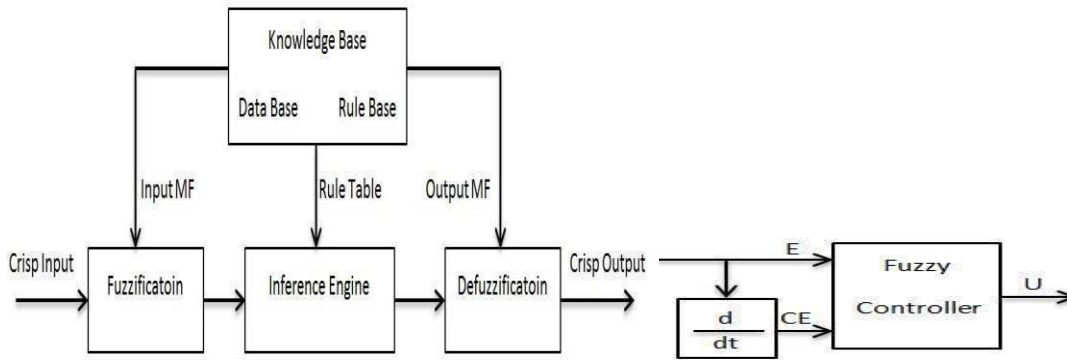

Figure 5: Basic structure of fuzzy logic controller. Fuzzy control system

4. PROPOSED MODEL FOR INDUCTION MOTOR SPEED CONTROLLER

The block diagram of proposed hybrid speed controller system for a vector control drive system is shown in figure 6. The two input variables of fuzzy system are the motor speed error E and change in error CE . The controller observes the speed loop error signal and correspondingly changes the output so that the actual speed ω_{act} matches the reference speed ω_{ref} .

The design of fuzzy system requires the choice of fuzzy sets and membership functions. The proposed fuzzy sets (linguistic definition) are defined as follow:

- PVB = Positive Very Big PB = Positive Big PM = Positive Medium PS = Positive Small
- Z = Zero Ns = Negative Small NM = Negative Medium NB = Negative Big
- NVB = Negative Very Big

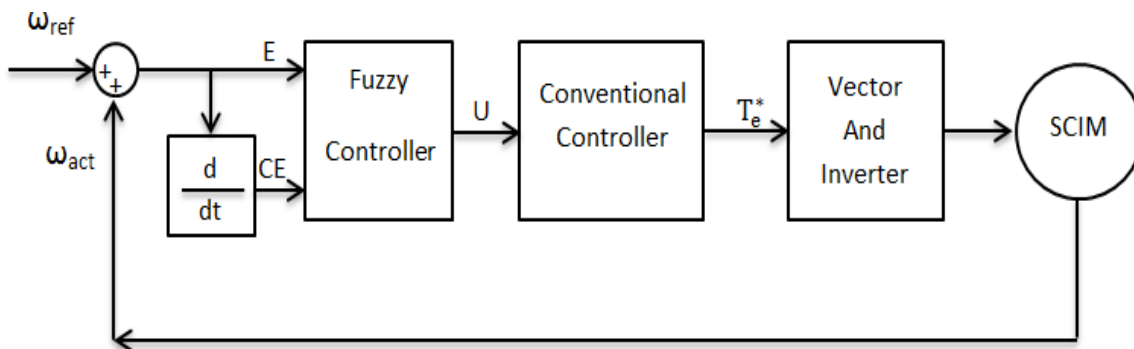

Figure 6: Proposed hybrid controller that combines fuzzy logic controller with conventional controller to drive SCIM

The most important step in designing fuzzy system is the design of the rule base. It consists of a number of fuzzy IF-THEN rules that define the behavior of the system. Table 2 shows the corresponding rule table for the proposed fuzzy control system. The top row of the matrix indicates the fuzzy sets of the error variable E and the left column indicates the change in error variable CE and the output variable U is shown in the body of the matrix.

Table 2 : Fuzzy rule base table to control the speed of induction motor

E	NB	NM	NS	Z	PS	PM	PB
NB	NVB	NVB	NVB	NB	NM	NS	Z
NM	NVB	NVB	NB	NM	NS	Z	PS

NS	NVB	NB	NM	NS	Z	PS	PM
Z	NB	NM	NS	Z	PS	PM	PB
PS	NM	NS	Z	PS	PM	PB	PVB
PM	NS	Z	PS	PM	PB	PVB	PVB
PB	Z	PS	PM	PB	PVB	PVB	PVB

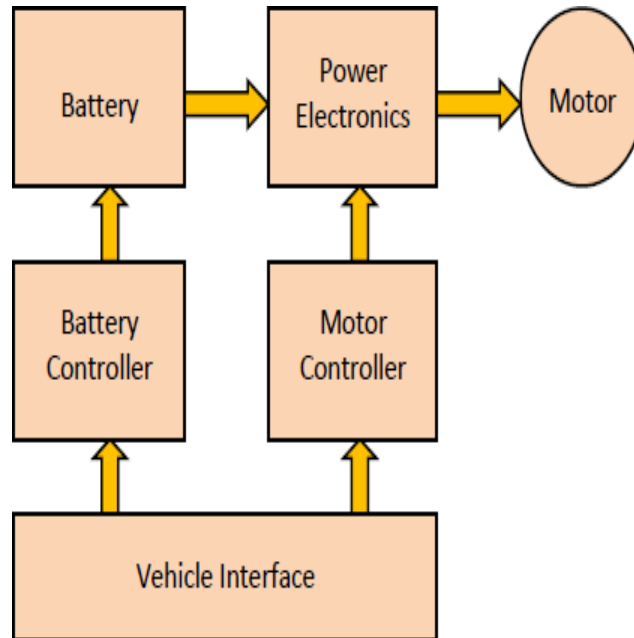

Figure 7: Block diagram to model the proposed scheme

To model an EV, all mathematical equations to represent each component in the EV drive train were determined. The motor, battery, motor controller and P-I controller were modelled in Matlab-Simulink platform into individual block diagram to form an EV drive system.

5. SIMULINK MODEL AND RESULTS

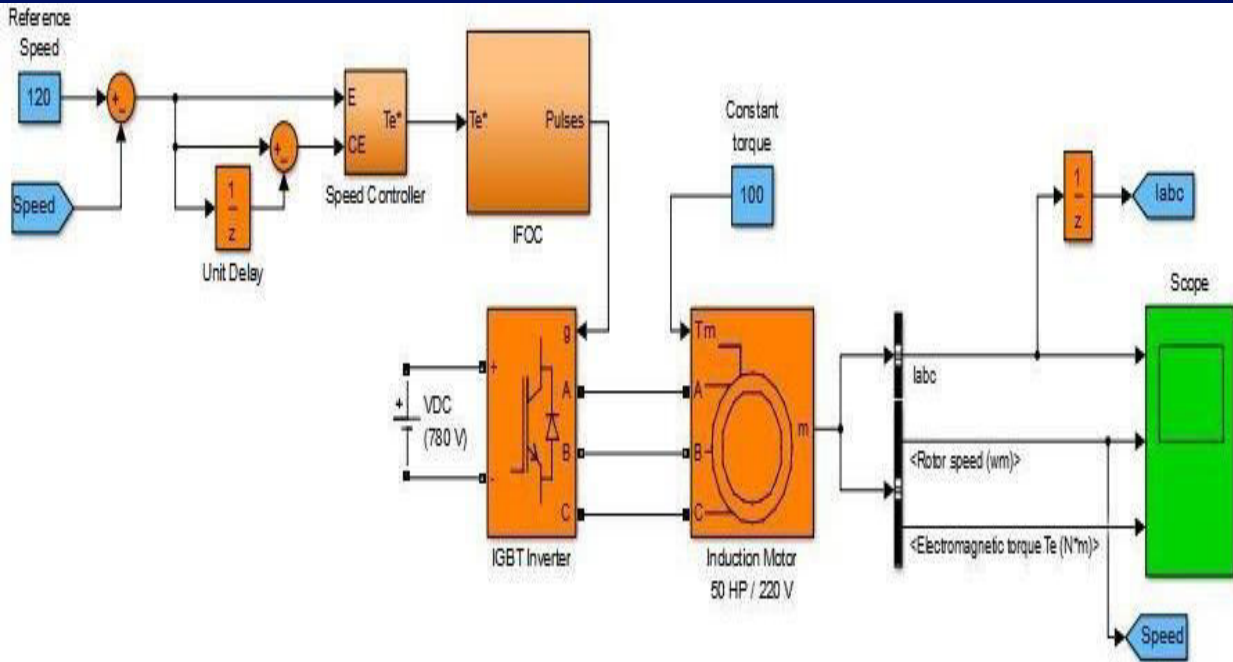

Figure 8: Complete SIMULINK model of speed controller system for three-phase squirrelcage induction motor

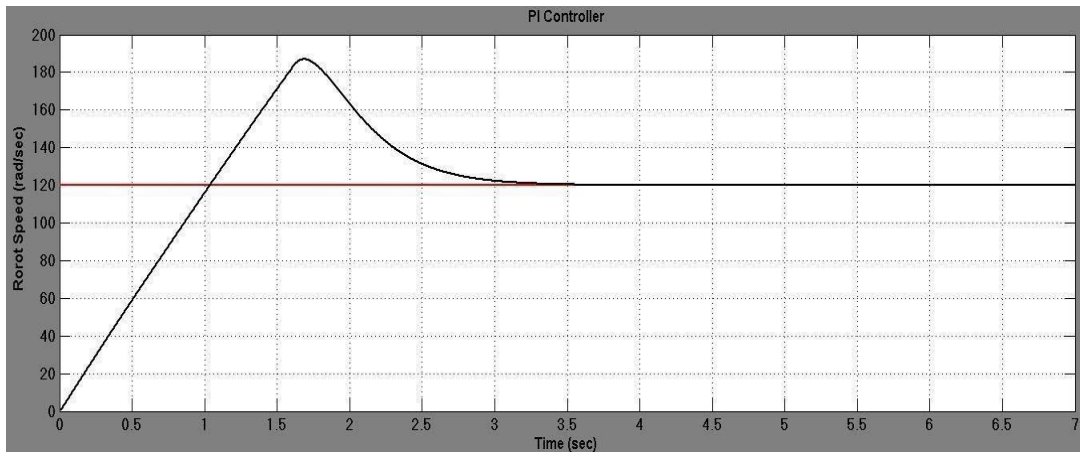

Figure 9: Speed response curve of SCIM at 100 N.m load torque and 120 rad/sec using PI controller

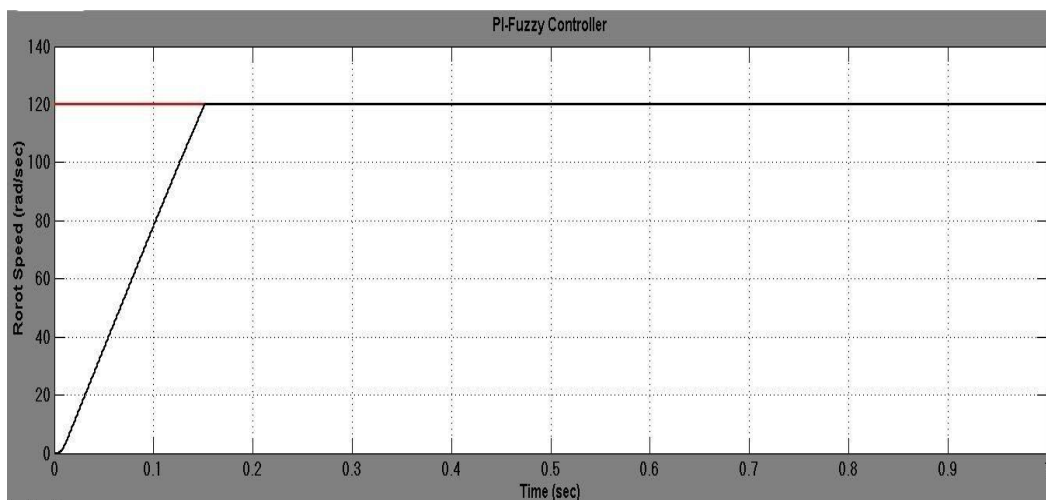

Figure 10: Speed response curve of SCIM at 100 N.m load torque and 120 rad/sec using PI-Fuzzy controller

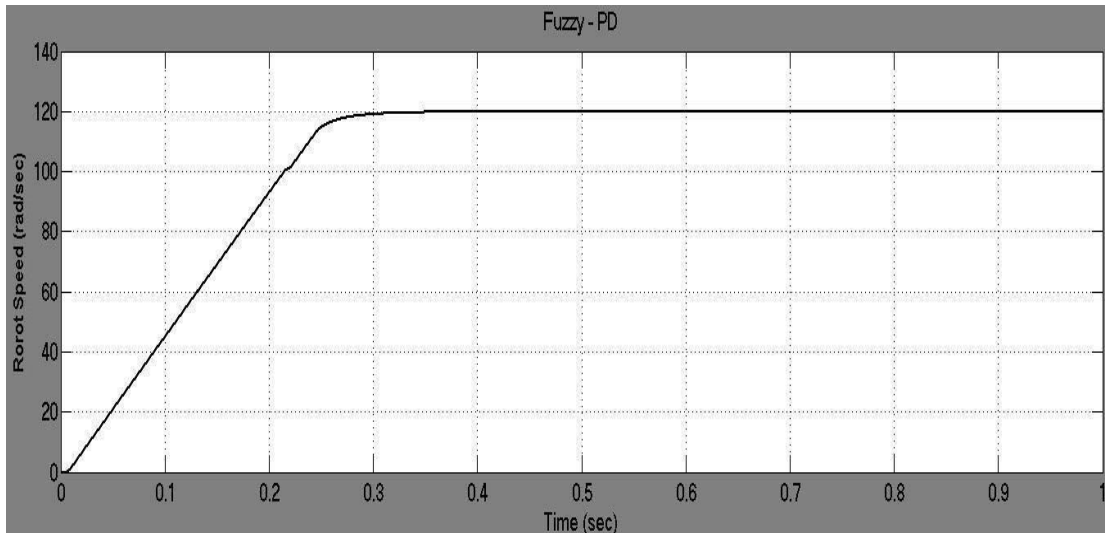

Figure 11: Speed response curve of SCIM at 100 N.m load torque and 120 rad/sec using PD-Fuzzy controller

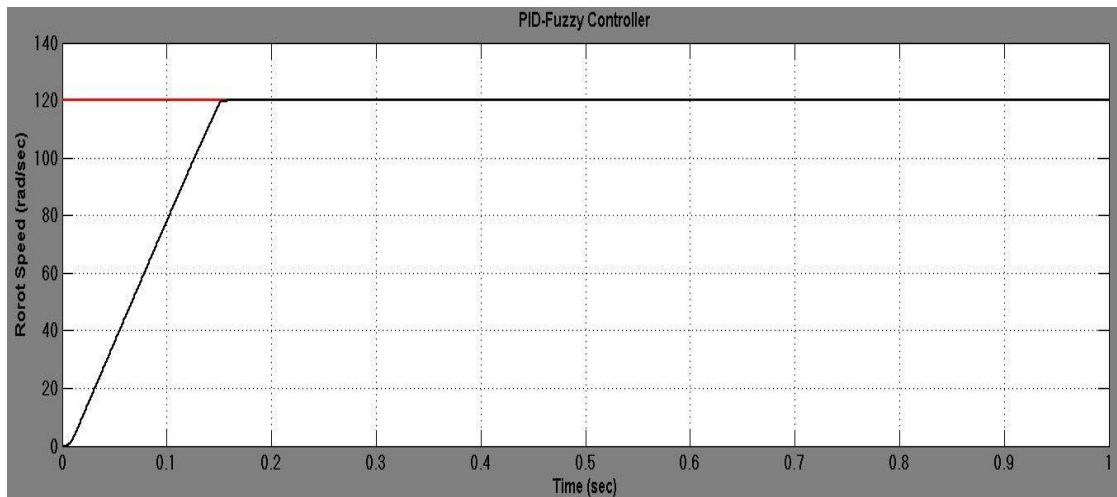

Figure 12: Speed response curve of SCIM at 100 N.m load torque and 120 rad/sec using PID-Fuzzy controller

Table 3: Performance analyses of different speed controllers for SCIM at 120 rad/sec reference speed and different load torque

Load (N.m)	Controller	t_r (sec)	t_s (sec)	M_p	e_{ss}
0	PI	0.5439	2.3053	45.6222	0.015
	PD-Fuzzy	0.1649	0.2246	0	0.004
	PI-Fuzzy	0.1071	0.1386	0.1423	0.1600
	PID-Fuzzy	0.1071	0.1386	0.0411	0.0460
100	PI	0.8264	2.9875	55.7523	0.005
	PD-Fuzzy	0.1815	0.2444	0	0.0570
	PI-Fuzzy	0.1146	0.1484	0.0994	0.1100
	PID-Fuzzy	0.1146	0.1484	0.0016	0.0005
150	PI	1.1171	3.7192	62.7390	0.0040
	PD-Fuzzy	0.1915	0.2563	0	0.0835
	PI-Fuzzy	0.1189	0.1539	0.0792	0.0880
	PID-Fuzzy	0.1189	0.1539	0	0.0205
200	PI	1.7215	5.2680	69.8961	0.007
	PD-Fuzzy	0.2027	0.2698	0	0.1098
	PI-Fuzzy	0.1234	0.1598	0.0591	0.0650

PID-Fuzzy	0.1234	0.1598	0	0.0440
-----------	--------	--------	---	--------

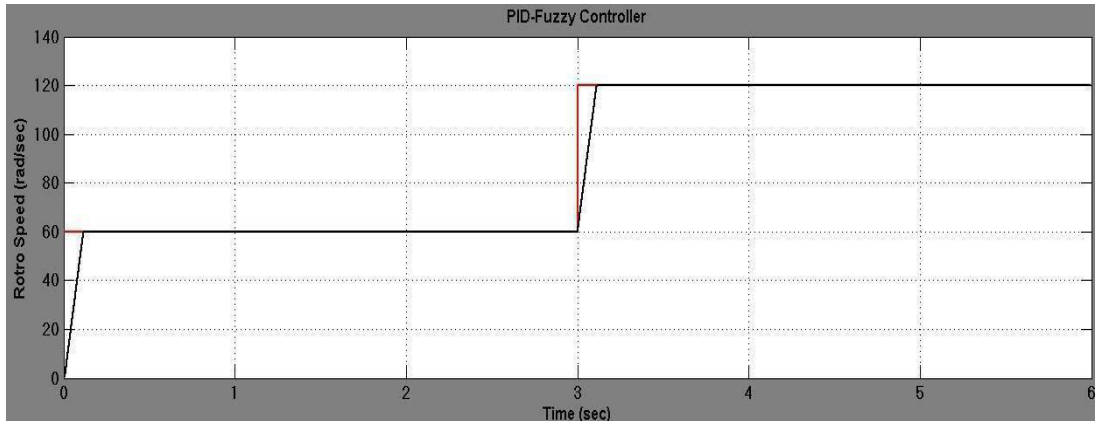

Figure 13: Speed response curve of SCIM at 100 N.m load torque and 60 to 120 rad/sec step change in w_{ref} using PI controller.

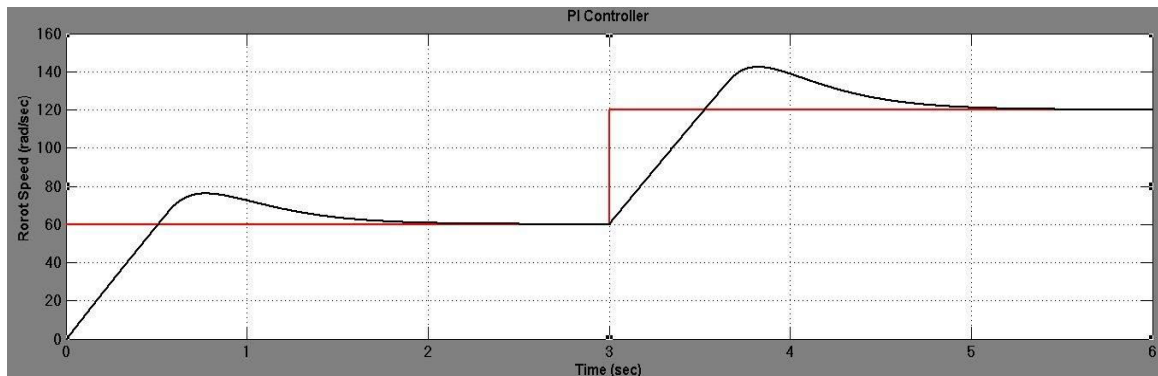

Figure 13: Speed response curve of SCIM at 100 N.m load torque and 60 to 120 rad/sec step change in w_{ref} using PID-Fuzzy controller.

6. PROTOTYPE IMPLEMENTATION

This paper presents solar PV powered Electric Vehicle, which solves the key downside of fuel and pollution. It is an initiative in implementing eco-friendly transportation in the world to build a green environment. In general, an electric vehicle uses a battery that is charged from an external power supply, but solar PV modules are used to charge a battery by means of absorbing radiation from the sun and converting it into electrical power (Photovoltaic Effect) by proposed method. The electrical power to batteries obtained from solar PV modules which might be associated either in series or parallel and charge controllers.

Table 3: Technical Specifications used for Solar powered EV

Vehicle weight	130 Kg without battery
Length, Breadth & Height	2060, 1340, 1234 (mm)
Body material	F.R.P.
Chassis Material	Aluminum Alloy & Cast Iron
Average speed	30 Km/hr
Top speed	40 Km/hr
Without sunlight	35 Km
Range in Sun light	∞ Km
Motor output	100 Watt (200 watt peak power)
Max load capacity	250 Kg
Battery	12 V, 20 AH – 4 Units
Battery complete charging time	4.5 Hrs (approx.) by solar power
Battery charging time by AC current	3 Hrs
Solar panel	100 Watt

Suspension System	Swing Trailing Arm (Front) Swing Arm (Rear)
Steering System	Rack and Pinion Type
Turing Radius	4.5 m
Brake System	Hydraulic Disc (Front) Hydraulic Disc (Rear) Size: F(200mm) and R(200mm)



Figure 14: a.Rear view of PV powered EV b. Front view of PV powered EV

7.CONCLUSION

This paper has successfully presented a hybrid PID-Fuzzy system for controlling a speed of a three-phase squirrel cage induction motor can be used for Electric Vehicle applications. Hybridization of fuzzy logic and conventional controllers is used as a single controller. Additionally, the indirect field oriented control is utilized in the proposed hybrid system to solve the induction motor coupling effects problem that makes the system response sluggish and easily prone to instability. PI, PD PID and with fuzzy were designed and simulated in MATLAB/Simulink. A comparative study of the different control schemes has been completed using the performance significant measures such as rise time (t_r), peak overshoot (M_p), settling time (t_s), and steady state error (E_{ss}).Based on simulation results verification, it is concluded that dynamic response characteristics with the hybrid PID-Fuzzy controller take less time to settle and do reach the final steady state value especially when compared with the PI conventional controller.

In conclusion, it was demonstrated that the proposed hybrid PID-Fuzzy speed controllerfor closed loop operation of the induction motor drive system has improved performance over the PI conventional controller and that it gives better speed response and shows higher levels of robustness and effectiveness. Modeling and simulation in Matlab-Simulink has shown to be of great value in investigating energy flow, performance and efficiency of the EV drive system. Inthis study, the simulation was performed and analyzed in both motoring and regeneration mode. The operation mode of the motor is determined by the road speed and torque requirements and subsequently by the polarity of motor current and voltage. The energy flows from battery to load during motoring but in opposite direction during regeneration. The proposed solar electric vehicles has several merits such as less pollution and Provides noiseless operation,EVs reduces our dependence on fossil fuels, No emission while running,low cost of operation& Fast and smooth acceleration.

REFERENCES

- [1] Ashok Kusagur, Shankarappa Fakirappa Kodad, and Sanker Ram, "Modelling & Simulation of an ANFIS controller for an AC drive," *World Journal of Modelling and Simulation*, vol. 8,no. 1, pp. 36-49, March 2011.
- [2] Amit Mishra and Zaheeruddin, "Design of Speed Controller for Squirrel-cage Induction Motor using



Fuzzy logic based Techniques," *International Journal of Computer Applications*, vol. 58, no. 22, pp. 10-18, November 2012.

- [3] Pabitra Kumar Behera, Manoj Kumar Behera, and Amit Kumar Sahoo, "Comparative Analysis of scalar & vector control of Induction motor through Modeling & Simulation," *INTERNATIONAL JOURNAL OF INNOVATIVE RESEARCH IN ELECTRICAL, ELECTRONICS, INSTRUMENTATION AND CONTROL ENGINEERING*, vol. 2, no. 4, pp. 1340-1344, April 2014.
- [4] Ch Chengaiah and Silva Prasad, "Performance of Inductoin Motor Drive by Indirect vector controlled method using PI and Duzzy Controllers," *International Journal of Science, Environment*, vol. 2, no. 3, pp. 475-469, 2013.
- [5] Sharda Patwa, "CONTROL OF STARTING CURRENT IN THREE PHASE INDUCTION MOTOR USING FUZZY LOGIC CONTROLLER," *International Journal of Advanced Technology in Engineering and Science*, vol. 1, no. 12, pp. 27-32, December 2013.