



# International Journal for Innovative Engineering and Management Research

A Peer Reviewed Open Access International Journal

www.ijiemr.org

**COPY RIGHT**



**ELSEVIER**  
**SSRN**

**2020IJIEMR.** Personal use of this material is permitted. Permission from IJIEMR must be obtained for all other uses, in any current or future media, including reprinting/republishing this material for advertising or promotional purposes, creating new collective works, for resale or redistribution to servers or lists, or reuse of any copyrighted component of this work in other works. No Reprint should be done to this paper, all copy right is authenticated to Paper Authors

IJIEMR Transactions, online available on 25th Sept 2021. Link

[:http://www.ijiemr.org/downloads.php?vol=Volum9/ISSUE-09](http://www.ijiemr.org/downloads.php?vol=Volum9/ISSUE-09)

**DOI: 10.48047/IJIEMR/V09/I09/37**

Title A CRANE HOOK'S DESIGN AND STRESS VALUES CALCULATION

Volume 09, Issue 09, Pages: 244-267

Paper Authors

**DR.RAVINAIK BANOTHU, DR.B.JAMES PRASADA RAO, K.MOUNIKA,  
B.VENKATESH, VISWANATH SRIRAM, DHARMAPURI MADHURI**



USE THIS BARCODE TO ACCESS YOUR ONLINE PAPER

To Secure Your Paper As Per **UGC Guidelines** We Are Providing A Electronic Bar Code

## A CRANE HOOK'S DESIGN AND STRESS VALUES CALCULATION

DR.RAVINAIK BANOTHU,DR.B.JAMES PRASADA RAO,K.MOUNIKA,  
B.VENKATESH,VISWANATH SRIRAM,DHARMAPURI MADHURI

Department Of MECHANICAL Ellenki College Of Engineering And Technology, TS, India.

### ABSTRACT

Crane Hooks are highly liable components and are always subjected to failure due to accumulation of large amount of stresses which can eventually lead to its failure. To study the stress pattern of crane hook in its loaded condition, a solid model of crane hook is prepared with the help of CAD software. Real time pattern of stress concentration in 3D model of crane hook is obtained. The present work is directed towards the modeling of a CAD tool called solid works and also analyzed in it by applying force on crane and determining the von misses stresses, after design and calculation of stress values, material selection is happened, and discussed each material properties,

### INTRODUCTION

A crane is a type of machine, generally equipped with a hoist, wire ropes or chains, and sheaves, that can be used both to lift and lower materials and to move them horizontally. It is mainly used for lifting heavy things and transporting them to other places. It uses one or more simple machines to create mechanical advantage and thus move loads beyond the normal capability of a man. Cranes are commonly employed in the transport industry for the loading and unloading of freight, in the construction industry for the movement of materials and in the manufacturing industry for the assembling of heavy equipment.

The first construction cranes were invented by the Ancient Greeks and were powered by men or beasts of burden, such as donkeys. These cranes were used for the construction

of tall buildings. Larger cranes were later developed, employing the use of human tread wheels, permitting the lifting of heavier weights. In the High Middle Ages, harbor cranes were introduced to load and unload ships and assist with their construction – some were built into stone towers for extra strength and stability. The earliest cranes were constructed from wood, but cast iron and steel took over with the coming of the Industrial Revolution.

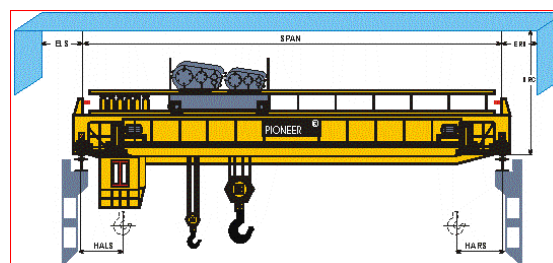

For many centuries, power was supplied by the physical exertion of men or animals, although hoists in watermills and windmills could be driven by the harnessed natural power. The first 'mechanical' power was provided by steam engines, the earliest steam crane being introduced in the 18th or 19th century, with many remaining in use well into the late 20th century. Modern cranes usually use internal combustion engines or electric motor and hydraulic systems to provide a much greater lifting capability than was previously possible, although manual cranes are still utilized where the provision of power would be uneconomic.

Cranes exist in an enormous variety of forms – each tailored to a specific use. Sometimes sizes range from the smallest jib cranes, used inside workshops, to the tallest tower cranes, used for constructing high buildings. For a while, mini - cranes are also used for constructing high buildings, in order to facilitate constructions by reaching tight spaces. Finally, we can find larger floating cranes, generally used to build oil rigs and salvage sunken ships.

This article also covers lifting machines that do not strictly fit the above definition of a crane, but are generally known as cranes,

such as stacker cranes and loader cranes.

## TYPES OF CRANES

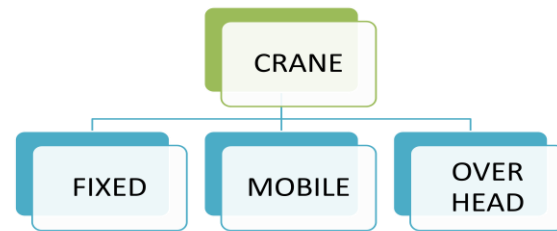

### Types of cranes:

- Overhead crane
- Mobile
  - 3.2.1 Truck-mounted crane
  - 3.2.2 Side lift crane
  - 3.2.3 Rough terrain crane
  - 3.2.4 All terrain crane
  - 3.2.5 Pick and carry crane
  - 3.2.6 Carry deck crane
  - 3.2.7 Telescopic handler crane
  - 3.2.8 Crawler crane
  - 3.2.9 Railroad crane
  - 3.2.10 Floating crane
  - 3.2.11 Aerial crane
- **3.3 Fixed:**
  - 3.3.1 Tower crane
  - 3.3.2 Self-erecting crane
  - 3.3.3 Telescopic crane
  - 3.3.4 Hammerhead crane
  - 3.3.5 Level luffing crane
  - 3.3.6 Gantry crane
  - 3.3.7 Deck crane
  - 3.3.8 Jib crane
  - 3.3.9 Bulk-handling crane
  - 3.3.10 Loader crane

## Overhead crane:



An overhead crane, also known as a bridge crane, is a type of crane where the hook-and-line mechanism runs along a horizontal beam that it self runs along two widely separated rails. Often it is in a long factory building and runs along rails along the building's two long walls. It is similar to a gantry crane. Overhead cranes typically consist of either a single beam or a double beam construction. These can be built using typical steel beams or a more complex box girder type. Pictured on the right is a single bridge box girder crane with the hoist and system operated with a control pendant. Double Girder Bridge are more typical when needing heavier capacity systems from 10 tons and above. The advantage of the box girder type configuration results in a system that has a lower deadweight yet a stronger overall system integrity. Also included would be a hoist to lift the items, the bridge, which spans the area covered by the crane, and a trolley to move along the bridge.

## Mobile:

Truck-mounted crane:



A crane mounted on a truck carrier provides the mobility for this type of crane. This crane has two parts: the carrier often referred to as the Lower, and the lifting component which includes the boom, referred to as the Upper. These are mated together through a turntable allowing the upper to swing from side to side. These modern hydraulic truck cranes are usually single-engine machines, with the same engine powering the undercarriage and the crane. The upper is usually powered via hydraulics run through the turntable from the pump mounted on the lower. In older model designs of hydraulic truck cranes there were 2 engines. One in the lower pulled the crane down the road and ran a hydraulic pump for the outriggers and jacks. The one in the upper ran the upper through a hydraulic pump of its own. Many older operators favor the 2 engine system due to leaking seals in the turntable of aging newer design cranes.

## Side lift crane:

A side lifter crane is a road-going truck or semi-trailer, able to hoist and transport ISO standard containers. Container lift is done

with parallel crane-like hoists, which can lift a container from the ground or from a railway vehicle.

### **Pick and carry crane:**

A Pick and Carry Crane is similar to a mobile crane in that is designed to travel on public roads, however pick and Carry cranes have no stabilizer legs or outriggers and are designed to lift the load and carry it to its destination, within a small radius, then be able to drive to the next job. Pick and Carry cranes are popular in Australia where large distances are encountered between job sites. One popular manufacturer in Australia was Farina, who have since been bought by Terex, and now all pick and carry cranes are commonly referred to as "Fran's" even though they may be made by other manufacturers. Nearly every medium and large sized crane company in Australia has at least one and many companies have fleets of these cranes.

### **Carry deck crane:**

A carry deck crane is a small 4 wheel crane with a 360 degree rotating boom placed right in the centre and an operators cab located at one end under this boom. The rear section houses the engine and the area above the wheels is a flat deck. Very Much an American invention the Carry deck can hoist a load in a confined space and then load it on the deck space around the cab or engine and subsequently move to another site. The Carry Deck principle is the American version of the pick and carry crane and both allow the load to be moved by the crane over short distances.

### **Telescopic handler crane:**

Telescopic Handlers are like forklift trucks that have a telescoping extendable boom like a crane. Early telescopic handlers only lifted in one direction and did not rotate, however, several of the manufacturers have designed telescopic handlers that rotate 360 degrees through a turntable and these machines look almost identical to the Rough Terrain Crane. These new 360 degree telescopic handler/crane models have outriggers or stabilizer legs that must be lowered before lifting,

### **Crawler crane:**

A crawler is a crane mounted on an undercarriage with a set of tracks (also called crawlers) that provide stability and mobility. Crawler cranes range in lifting capacity from about 40 to 3,500 short tons (35.7 to 3,125.0 long tons; 36.3 to 3,175.1 t).

Crawler cranes have both advantages and disadvantages depending on their use. Their main advantage is that they can move around on site and perform each lift with little set-up, since the crane is stable on its tracks with no outriggers. In addition, a crawler crane is capable of traveling with a load. The main disadvantage is that they are very heavy, and cannot easily be moved from one job site to another without significant expense. Typically a large crawler must be disassembled and moved by trucks, rail cars or ships to its next location.

### **Floating crane:**

Floating cranes are used mainly in bridge building and port construction, but they are also used for occasional loading and unloading of especially heavy or awkward

loads on and off ships. Some floating cranes are mounted on a pontoon, others are specialized crane barges with a lifting capacity exceeding 10,000 short tons (8,929 long tons; 9,072 t) and have been used to transport entire bridge sections. Floating cranes have also been used to salvage sunken ships.



**Aerial crane:**



Aerial crane or 'Sky cranes' usually are helicopters designed to lift large loads. Helicopters are able to travel to and lift in areas that are difficult to reach by conventional cranes. Helicopter cranes are most commonly used to lift units/loads onto shopping centers and high rises. They can lift anything within their lifting capacity, (cars, boats, swimming pools, etc.).

### 3.3 Fixed:

Exchanging mobility for the ability to carry greater loads and reach greater heights due to increased stability, these types of cranes are characterized by the fact that their main structure does not move during the period of use. However, many can still be assembled and disassembled.

#### Self-erecting crane:



Generally a type of tower crane, these cranes, also called self-assembling, jack-up, or "kangaroo" cranes, lift themselves from the ground or lift an upper, telescoping section using jacks, allowing the next section of the tower to be inserted at ground level or lifted into place by the partially erected crane itself. They can thus be assembled without outside help, and can grow together with the building or structure they are erecting.

## Telescopic crane:



A telescopic crane has a boom that consists of a number of tubes fitted one inside the other. A hydraulic or other powered mechanism extends or retracts the tubes to increase or decrease the total length of the boom. These types of booms are often used for short term construction projects, rescue jobs, lifting boats in and out of the water, etc. The relative compactness of telescopic booms makes them adaptable for many mobile applications.

### Function of Crane:

Overhead bridge cranes have long been used in factories and warehouses to hoist and move heavy objects, often in small or cramped areas that may not allow for proper and safe maneuvering of forklift trucks. An overhead bridge crane can remedy this situation by providing an effective manner to hoist and move heavy loads that require significant power capability. It can readily meet numerous requirements that are sometimes performed by other types of equipment.

## Types:

Overhead bridge cranes can be divided into two groups: top-running bridge cranes and under-running bridge cranes. The primary distinction is the manner in which the end trucks are attached to the crane. Top-running overhead bridge cranes have the end trucks supported on rails attached to the top of the crane runway, while under-running bridge cranes have the end trucks supported on tracks attached to the bottom flanges of the beams.

### USES OF CRANE:

1. IT IS USED FOR LIFTING
2. IT IS ALSO USED FOR MOVING MATERIAL
3. TRANSPORT HEAVY LOADS
4. DECREASES HUMAN WORK LOAD
5. CONSTRUCTION FIELD
6. RESCUE OPERATIONS

### Benefits:

The benefits of an overhead bridge crane, whether top-running or under-running, are fairly numerous and can be significant solutions to alternative methods such as forklifts and elevators. A major benefit is that overhead bridge cranes are considerably less expensive than other options. They are also of a relatively simple design, lending to ease of operation and can be ordered as kits and installed on-site by the purchaser. They are designed so that in case of failure, they lock their load in place and prevent it from falling.

## **Shortcomings of Overhead Bridge**

### **Cranes:**

The primary—and possibly only—drawback to having an overhead bridge crane is that they are not very mobile. However, even this situation can be remedied by installing a track network to extend the range of the crane. This added expense still allows an overhead bridge crane to be a more economical choice than a forklift. The fact that an overhead bridge crane can actually reduce or even eliminate the need for forklifts or freight elevators is also a considerable benefit.

## **PREVENTATIVE MAINTENANCE:**

Many crane owners have inspections performed on an annual basis. This is an OSHA requirement. What many companies don't know is OSHA also requires that the crane must be maintained on a scheduled basis, complete with dated records based upon the manufacturer's criteria. The maintenance can be performed in house or by a third party and the schedule is based on the duty cycle of the equipment along with following the manufacturer's requirements.

Aside from the mandatory requirements listed and their costs, there may be additional costs involved by doing only an annual inspection. Historically, cranes with only an annual inspection/preventive maintenance service incur more breakdowns than cranes serviced quarterly. Small problems or adjustments normally taken care of during a quarterly

inspection/preventive maintenance service have become bigger problems by the time the annual inspection/preventive maintenance service is due. Deficiencies found on an annual inspection/preventive maintenance service may be multiplied vs. cranes being inspected and maintained quarterly.

When breakdowns do occur, production time is lost and repair costs rise. If one was to look at two identical cranes of the same age, running at the same duty cycle and one unit maintained quarterly, the other maintained annually; you would find that the equipment maintained annually would cost more in higher operating costs, with lost time and expensive repair bills.

## **Benefits of Performing a Quarterly Inspection/Preventive Maintenance Service:**

- 1) Lower your costs on repairs, including expediting costs and airfreight bills when purchasing replacement parts.
- 2) Decrease your equipment down time due to breakdowns.
- 3) Allows you, the Crane Owner and Crane Service Company to schedule repairs around your production.
- 4) Provides you and your staff advanced notice of equipment condition for future and existing budget requirements.



5) The above cost savings alone can be enough to allow for future upgrades or equipment replacement.

Are you proactive or reactive when it comes to maintaining your overhead cranes and hoists? Why take a chance, let a qualified Crane –Tec specialist recommend the correct program for your operation

### LD Electric single-girder overhead crane

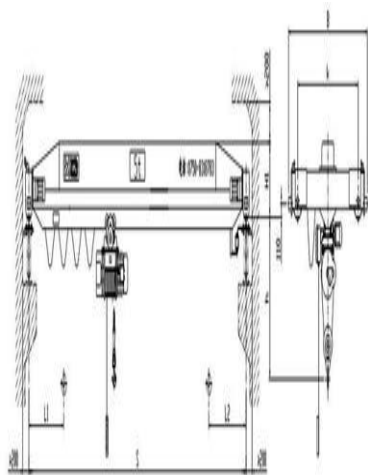

### Specification:

- 1, This crane is versatile one of light-small cranes, available for workshop or
- 2,
  - CO<sup>2</sup> arc welding and submerged arc welding, one of which of main
  - Non-section and suspended cable with C-shaped groove conductor of
  - Electrical motor with soft-starter, applied
- 3, This crane can NOT be used in potentially explosive or 1 with high humidity or full of acid-base gas , and NOT flammable and exp
- 4, Three modes of control for choice:



### FORGED CRANE HOOK:

- PROPER DESIGN, CAREFUL FORGING, AND PRECISION CONTROLLED QUENCH

AND TEMPERING GIVE MAXIMUM STRENGTH WITHOUT EXCESSIVE WEIGHT AND BULK.

- AVAILABLE IN CARBON STEEL, ALLOY STEEL

## **HOOK FAILURE**

To minimize the failure of crane hook, the stress induced in it must be studied. Crane is subjected to continuous loading and unloading. This causes fatigue of the crane hook but the fatigue cycle is very low. If a crack is developed in the crane hook, it can cause fracture of the hook and lead to serious accident. In ductile fracture, the crack propagates continuously and is more easily detectible and hence preferred over brittle fracture. In brittle fracture, there is sudden propagation of the crack and hook fails suddenly. This type of fracture is very dangerous as it is difficult to detect.

Strain aging embrittlement due to continuous loading and unloading changes the microstructure. Bending stress and tensile stress, weakening of hook due to wear, plastic deformation due to overloading, and excessive thermal stresses are some of the other reasons for failure. Hence continuous use of crane hooks may increase the magnitude of these stresses and ultimately result in failure of the hook.

## **LITERATURE SURVEY**

The comparative study by Mr. A Gopichand. Et al. [1] has shown that taguchi method can be used for optimization of crane hook. In his work optimization of

design parameters is carried out using Taguchi method. He considered total three parameters and made mixed levels a L16 orthogonal array. The optimum combination of input parameters for minimum Vonmises stresses Are determined. From that array he found optimum combination of area radius for minimum Vonmises stress.

Ram Krishna rathour. et al. [2] has worked on a general approach for the multiple responses. He started optimization with the regression models to calculate the correlation between response function and control function. An objective function is generated with the helpof system for collecting various response functions together. By using artificial neural network (ANN) to find out the response function. He used multiple objective genetic algorithms (MOGA) to optimize shape function of the crane hook for same capacity by considering combination of objective function to find out the optimize shape of crane hook. The result shows that the reduction in mass as well as safety of factor is not disturbed.

Nishantsoni et al. [3] has worked on the optimization of low carbon steel for its self-weight. The self-weight and component load coming on the crane-hook hence he worked with objective of the optimization of the mass for cane hook-under the effect of static load comprising the peak pressure load. He used finite element analysis for the shape optimization of crane hook as well as for validation of final geometry.

Chetan N. Benkar.et al. [4] worked on crane hook for the optimization. He estimated the stress pattern of crane hook in

its loaded condition by preparing a solid model with the help of ANSYS 14 workbench. He calculated stress pattern for various cross section topology such as rectangular, triangular, trapezoidal, and circular by keeping the area constant and found that rectangular cross sectional area gives minimum stress and deformation level.

Rashmi Uddanwadiker.et.al. [5] Has calculated the stress pattern produced due to the load on hook. He compared the analytical result of stress and the stress estimated from the FEM analysis and found that there was 8.26% percent error between them. Photo elasticity test is based on the property of birefringence. From the analysis he found the area at which high stress concentration occurs. For the design improvement if the inner side of hook at the portion of maximum stress is widened then the stress will get reduced. He estimated that the stress is reduced up to 17% if the thickness of the inner curvature is reduced by 3mm

C. Oktay Azeloglu.et al. [6] has studied the method for the calculation of stress based on the different assumption. He adopted Timoshenko's curved theory and Bach approximation on the simple hooks calculation. He used finite element method to estimate the stress and compared it with different method.

M. Shaban. et al [7] prepared a solid model of crane hook to estimate the pattern of stress in the crane hook. They used ABAQUS software and obtained real time pattern of stress concentration. The value and location is very much important factor

in reducing the failure. If the inner curvature of hook is widened the stress will be reduced. For complicated mechanical element it is suitable to use caustic method. In caustic method several small several holes are drilled to predict accurate stress value.

Takuma Nishimura.et al. [8] studied damage factor estimation of crane hooks to recognize the tendency of the load condition. They used FEM to estimate the relation between the load condition and its deformation. First, load –deformation database that has the relation between the load condition of crane hook and its deformation using numerical calculation is constructed. After the completion of study they found that load acts in downward position and tip –end position and load direction is not downward normal in damaged hook.

Santosh Sahu.et al. [9] made a model of crane hook of trapezoidal using CATIA V5R20.Then estimated the location of stress after Applying the 2 ton load using FEM. They also analyzed the effect of variation in length of two parallel sides of trapezoidal hook on stress.

Apeksha K Patel.et al. [10] has worked on reduction of weight of girder which has reduced the cost of girder and also life of girder is increased. They made a mathematical design for crane component by using ANSYS workbench V12.They also optimized hook by using Trapezoidal cross sectional area.

Pradyumnakeshriharana. [11] Has estimated hook dimensions for various cross

section topology by keeping the depth and cross section area. He concludes from his work that the trapezoidal section was least stressed

.SpasojeTrifkovic' et al[12] worked on the stress state in the crane hook using exact and approximate methods. Stresses are calculated in various regions of the crane hook material by assuming crane hook as a straight beam and curved beam.

Torres et al [13] worked on the causes which led to failure of the crane hook in service. This study shows the simulation of the thermal history of the hook and explains the standards governing the manufacturing

## INTRODUCTION TO CAD

**Computer-aided design (CAD)**, also known as **computer-aided design and drafting (CADD)**, is the use of computer technology for the process of design and design-documentation. Computer Aided Drafting describes the process of drafting with a computer. CADD software, or environments, provides the user with input-tools for the purpose of streamlining design processes; drafting, documentation, and manufacturing processes. CADD output is often in the form of electronic files for print or machining operations. The development of CADD-based software is in direct correlation with the processes it seeks to economize; industry-based software (construction, manufacturing, etc.) typically uses vector-based (linear) environments

whereas graphic-based software utilizes raster-based (pixilated) environments.

CADD environments often involve more than just shapes. As in the manual drafting of technical and engineering drawings, the output of CAD must convey information, such as materials, processes, dimensions, and tolerances, according to application-specific conventions.

CAD may be used to design curves and figures in two-dimensional (2D) space; or curves, surfaces, and solids in three-dimensional (3D) objects.

CAD is an important industrial art extensively used in many applications, including automotive, shipbuilding, and aerospace industries, industrial and architectural design, prosthetics, and many more. CAD is also widely used to produce computer animation for special effects in movies, advertising and technical manuals. The modern ubiquity and power of computers means that even perfume bottles and shampoo dispensers are designed using techniques unheard of by engineers of the 1960s. Because of its enormous economic importance, CAD has been a major driving force for research in computational geometry, computer graphics (both hardware and software), and discrete differential geometry.

The design of geometric models for object shapes, in particular, is often called *computer-aided geometric design (CAGD)*.

Current computer-aided design software packages range from 2D vector-based drafting systems to 3D solid and surface modelers. Modern CAD packages can also frequently allow rotations in three dimensions, allowing viewing of a designed object from any desired angle, even from the inside looking out. Some CAD software is capable of dynamic mathematic modeling, in which case it may be marketed as **CADD** — *computer-aided design and drafting*.

CAD is used in the design of tools and machinery and in the drafting and design of all types of buildings, from small residential types (houses) to the largest commercial and industrial structures (hospitals and factories).

CAD is mainly used for detailed engineering of 3D models and/or 2D drawings of physical components, but it is also used throughout the engineering process from conceptual design and layout of products, through strength and dynamic analysis of assemblies to definition of manufacturing methods of components. It can also be used to design objects.

CAD has become an especially important technology within the scope of computer-aided technologies, with benefits such as lower product development costs and a greatly shortened design cycle. CAD enables designers to lay out and develop work on screen, print it out and save it for future editing, saving time on their drawings.

## Types of CAD Software

### 2D CAD

Two-dimensional, or 2D, CAD is used to create flat drawings of products and structures. Objects created in 2D CAD are made up of lines, circles, ovals, slots and curves. 2D CAD programs usually include a library of geometric images; the ability to create Bezier curves, splines and polylines; the ability to define hatching patterns; and the ability to provide a bill of materials generation. Among the most popular 2D CAD programs are AutoCAD, CAD key, CADD5, and Medusa.

### 3D CAD

Three-dimensional (3D) CAD programs come in a wide variety of types, intended for different applications and levels of detail. Overall, 3D CAD programs create a realistic model of what the design object will look like, allowing designers to solve potential problems earlier and with lower production costs. Some 3D CAD programs include Autodesk Inventor, Co Create Solid Designer, Pro/Engineer Solid Edge, Solid Works, Unigraphics NX and VX CAD, CATIA V5.

### 3D Wireframe and Surface Modeling

CAD programs that feature 3D wireframe and surface modeling create a skeleton-like inner structure of the object being modeled. A surface is added on later. These types of CAD models are difficult to translate into other software and are therefore rarely used anymore.

## **Solid Modeling**

Solid modeling in general is useful because the program is often able to calculate the dimensions of the object it is creating. Many sub-types of this exist. Constructive Solid Geometry (CSG) CAD uses the same basic logic as 2D CAD, that is, it uses prepared solid geometric objects to create an object. However, these types of CAD software often cannot be adjusted once they are created. Boundary Representation (Brep) solid modeling takes CSG images and links them together. Hybrid systems mix CSG and Brep to achieve desired designs.

Solid Works is a solid modeling computer-aided design (CAD) and computer-aided engineering (CAE) computer program that runs on Microsoft Windows. SolidWorks is published by Dassault Systems. According to the publisher, over two million engineers and designers at more than 165,000 companies were using SolidWorks as of 2013. Also according to the company, fiscal year 2011–12 revenue for SolidWorks totaled \$483 million

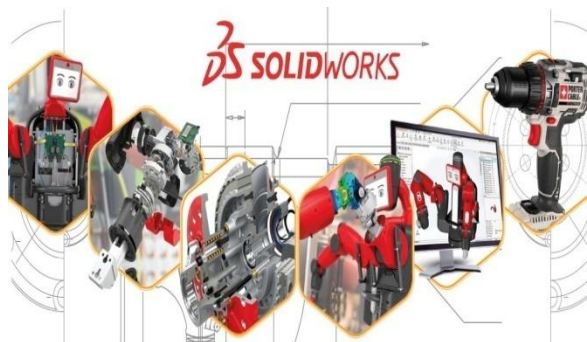

## **History**

SolidWorks Corporation was founded in December 1993 by Massachusetts Institute of Technology graduate Jon Hirschtick.

Hirschtick used \$1 million he had made while a member of the MIT Blackjack Team to set up the company. Initially based in Waltham, Massachusetts, United States, Hirschtick recruited a team of engineers with the goal of building 3D CAD software that was easy-to-use, affordable, and available on the Windows desktop. Operating later from Concord, Massachusetts, SolidWorks released its first product SolidWorks 95, in November 1995. In 1997 Dassault, best known for its SOLIDWORKS CAD software, acquired SolidWorks for \$310 million in stock. Jon Hirschtick stayed on board for the next 14 years in various roles. Under his leadership, SolidWorks grew to a \$100 million revenue company.

SolidWorks currently markets several versions of the SolidWorks CAD software in addition to eDrawings, a collaboration tool, and DraftSight, a 2D CAD product. SolidWorks was headed by John McEleney from 2001 to July 2007 and Jeff Ray from 2007 to January 2011. The current CEO is Gian Paolo Bassi from Jan 2015. Gian Paolo Bassi replaces Bertrand Sicot, who is promoted Vice President Sales of Dassault Systèmes' Value Solutions sales channel. DS Solidworks Corp. has sold over 3.5 million licenses of SolidWorks worldwide. This includes a large proportion of educational licenses. The Sheffield Telegraph comments that Solidworks is the world's most popular CAD software.

Its user base ranges from individuals to large corporations, and covers a very wide cross-section of manufacturing market segments.



Commercial sales are made through an indirect channel, which includes dealers and partners throughout the world. In the United States, the first reseller of SolidWorks, in 1995, was Computer Aided Technology, Inc, headquartered in Chicago. Directly competitive products to SolidWorks include PTC

Solidworks Elements/Pro, Solid Edge, and Autodesk Inventor. SolidWorks also partners with third party developers to add functionality in niche market applications like finite element analysis, circuit layout, tolerance checking, etc. SolidWorks has also licensed its 3D modeling capabilities to other CAD software vendors, notably ANVIL

SolidWorks is a solid modeler, and utilizes a parametric feature-based approach which was initially developed by PTC (Solidworks/Pro-Engineer) to create models and assemblies. The software is written on Parasolid-kernel.

Parameters refer to constraints whose values determine the shape or geometry of the model or assembly. Parameters can be either numeric parameters, such as line lengths or circle diameters, or geometric parameters, such as tangent, parallel, concentric, horizontal or vertical, etc. Numeric parameters can be associated with each other through the use of relations, which allows them to capture design intent.

Design intent is how the creator of the part wants it to respond to changes and updates. For example, you would want the hole at the top of a beverage can to stay at the top surface, regardless of the height or size of the can. SolidWorks allows the user to

specify that the hole is a feature on the top surface, and will then honor their design intent no matter what height they later assign to the can.

Features refer to the building blocks of the part. They are the shapes and operations that construct the part. Shape-based features typically begin with a 2D or 3D sketch of shapes such as bosses, holes, slots, etc. This shape is then extruded or cut to add or remove material from the part. Operation-based features are not sketch-based, and include features such as fillets, chamfers, shells, applying draft to the faces of a part, etc.

Building a model in SolidWorks usually starts with a 2D sketch (although 3D sketches are available for power users). The sketch consists of geometry such as points, lines, arcs, conics (except the hyperbola), and splines. Dimensions are added to the sketch to define the size and location of the geometry. Relations are used to define attributes such as tangency, parallelism, perpendicularity, and concentricity. The parametric nature of SolidWorks means that the dimensions and relations drive the geometry, not the other way around. The dimensions in the sketch can be controlled independently, or by relationships to other parameters inside or outside of the sketch.

In an assembly, the analog to sketch relations are mates. Just as sketch relations define conditions such as tangency, parallelism, and concentricity with respect to sketch geometry, assembly mates define equivalent relations with respect to the individual parts or components, allowing the

easy construction of assemblies. SolidWorks also includes additional advanced mating features such as gear and cam follower mates, which allow modeled gear assemblies to accurately reproduce the rotational movement of an actual gear train.

Finally, drawings can be created either from parts or assemblies. Views are automatically generated from the solid model, and notes, dimensions and tolerances can then be easily added to the drawing as needed. The drawing module includes most paper sizes and standards (ANSI, ISO, DIN, GOST, JIS, BSI and SAC).

### **File format**

SolidWorks files (previous to version 2015) use the Microsoft Structured Storage file format. This means that there are various files embedded within each SLDDRW (drawing files), SLDPRT (part files), SLDASM (assembly files) file, including preview bitmaps and metadata sub-files. Various third-party tools (see COM Structured Storage) can be used to extract these sub-files, although the subfiles in many cases use proprietary binary file formats.

### **Capabilities and Benefits:**

1. Complete 3D modeling capabilities enable you to exceed quality and time to market goals.
2. Maximum production efficiency through automated generation of associative CAD tooling design,

assembly instructions, and machine code.

3. Ability to simulate and analysis virtual prototype to improve production performance and optimized product design.
4. Ability to share digital product data seamlessly among all appropriate team members
5. Compatibility with myriad CAD tools-including associative data exchange and industry standard data formats.

### **2.4 Features of SOLIDWORKS**

SOLIDWORKS is a one-stop for any manufacturing industry. It offers effective feature, incorporated for a wide variety of purpose. Some of the important features are as follows:

- Simple and powerful tool
- Parametric design
- Feature-based approach
- Parent child relationship
- Associative and model centric

#### **2.4.1. Simple and Powerful Tool**

SOLIDWORKS tools are used friendly. Although the execution of any operation using the tool can create a highly complex model

#### **2.4.2. Parametric Design**

SOLIDWORKS designs are parametric. The term “parametric” means that the design operations that are captured can be stored as they take place. They can be used effectively



in the future for modifying and editing the design. These types of modeling help in faster and easier modifications of design

### **2.4.3. Feature-Based Approach**

Features are the basic building blocks required to create an object. SOLIDWORKS wildfire models are based on the series of feature. Each feature builds upon the previous feature, to create the model (only one single feature can be modified at a time). Each feature may appear simple, individually, but collectively forms a complex part and assemblies.

The idea behind feature based modeling is that the designer construct on object, composed of individual feature that describe the manner in which the geometry supports the object, if its dimensions change. The first feature is called the base feature.

### **2.4.4. Parent Child Relationship**

The parent child relationship is a powerful way to capture your design intent in a model. This relationship naturally occurs among features, during the modeling process. When you create a new feature, the existing feature that are referenced, become parent to the feature.

### **2.4.5. Associative and Model Centric**

SOLIDWORKS drawings are model centric. This means that SOLIDWORKS models that are represented in assembly or drawings are associative. If changes are made in one module, these will automatically get updated in the referenced module.

### **2.5. SOLIDWORKS Basic Design Modes**

When a design from conception to completion in SOLIDWORKS, the design information goes through three basic design steps.

1. Creating the component parts of the design
2. Joining the parts in an assembly that records the relative position of the parts.
3. Creating mechanical drawing based on the information in the parts and the assembly.

### **2.6 Assembly in SOLIDWORKS: Bottom-Up Design (Modeling):**

The components (parts) are created first and then added to the assembly file. This technique is particularly useful when parts already exist from previous designs and are being re-used.

### **Top-Down Design (Modeling):**

The assembly file is created first and then the components are created in the assembly file. The parts are build relative to other components. Useful in new designs

In practice, the combination of Top-Down and Bottom-Up approaches is used. As you often use existing parts and create new parts in order to meet your design needs.

### **Degrees of Freedom:**

An object in space has six degrees of freedom.

- **Translation** – movement along X, Y, and Z axis (three degrees of freedom)

- **Rotation** – rotate about X, Y, and Z axis (three degrees of freedom)

Assembly Constraints:

In order to completely define the position of one part relative to another, we must constrain all of the degrees of freedom  
**COINCIDENT, OFFSET**

### OFFSET

Two surfaces are made parallel with a specified offset distance.

### COINCIDENT

Two selected surfaces become co-planar and face in the same direction. Can also be applied to revolved surfaces. This constrains 3 degrees of freedom (two rotations and one translation). When Align is used on revolved surfaces, they become coaxial (axes through the centers align).

### SOLIDWORKS Modules:-

- Sketcher (2D)
- Part (3D)
- Assembly
- Drawing and Drafting
- Sheet Metal
- Surface modeling

### Crane hook Calculation

Components having curved portions are frequently subjected to axial or bending loads or to a combination of bending and axial loads. The stress due to curvature become greater and the results of the equations of straight beams when used becomes less satisfactory, with the reduction in the radius of curved portion. The dimensions for crane hook are taken as follows: 1) Bed diameter  $C = x\sqrt{P}$ , mm  $C = 3.12 \times 103$  Where,  $P$ =load, 49.82 KN

$X$ =constant ranging between 12 to 24. For economic design,  $x$  should be as minimum as possible. 2) Throat of Hook (J):  $2.34 \times 103$  mm 3) Depth of cross-section area:  $h = 70.89 \times 103$ mm 4) Width of cross-section (b):  $b_i = 46.08 \times 103$ mm 5) Parameter of cross-section: The inner surface of the cross-section is called as intrados while the outer surface is called as extrados The parameters of cross-section area are:  $R_i = 53.16 \times 103$ mm  $R_2 = 8.86 \times 103$ mm  $O_1O_2 = 8.86 \times 103$ mm 6) Radius of intrados and extrados:  $R_i = 1.56 \times 103$ mm  $R_0 = 110.58 \times 106$ mm 7) Stress in crane Hook:- The crane hook is a curved bar subjected to: -

Direct stress( $\sigma_d$ ) - Bending stress( $\sigma_b$ ) In curved beam the bending stress distribution is non-linear. In curved beam, the neutral axis does not coincide with the centroid or geometrical axis but is shifted towards the centre of curvature by distance "e".

This is due to non-linear distribution of bending stress. 8) Resultant stress at inner surface of crane hook( $\sigma_i$ ):  $A = 10.19 \times 103$  mm<sup>2</sup>

$$M = 4.14 \times 109 \text{ N-mm}$$

$$\sigma_d = 4.88 \text{ N/mm}^2$$

$$\sigma_b = 75.83 \text{ N/mm}^2$$

$$\sigma_i = \sigma_d + \sigma_b = 4.44 + 65.83 \sigma_i = 80.71 \text{ N/mm}^2$$

9) Resultant stress at outer surface of crane hook

$$\sigma_o = \sigma_d + \sigma_{bo}$$

$$\sigma_o = \frac{P}{A} + \frac{Mh_i}{AeR_i}$$

The resultant stress at inner surface is additional of tension stress due to direct load and tensile stress due to bending moment.

Thus, net stress is addition of two stresses. The resultant stress at outer surface is tensile stress due to direct load and compressive stress due to bending moment. Thus, net stress is different of two stresses.

10) Distance for Trapezoidal Cross-section:-

$$RN = 6.66$$

$$RG = 83.30 \times 10^3$$

$$e = Rg - RN$$

$$e = 83.30 \times 10^3 - 6.66$$

$$e = 83.29 \times 10^3$$

### 3-D MODELS OF CRANE HOOK

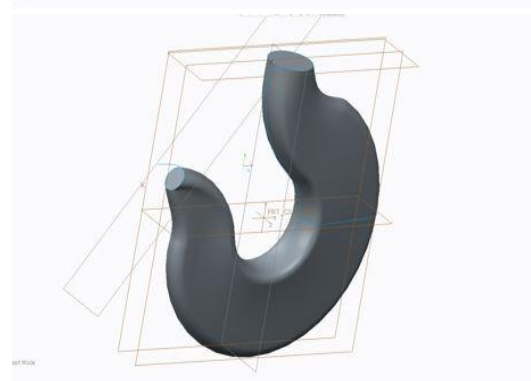
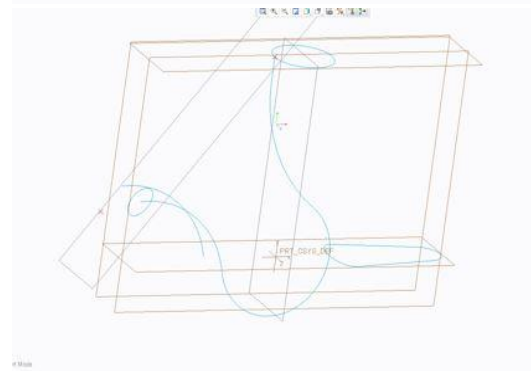
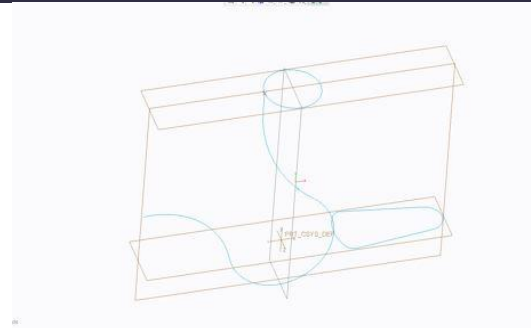
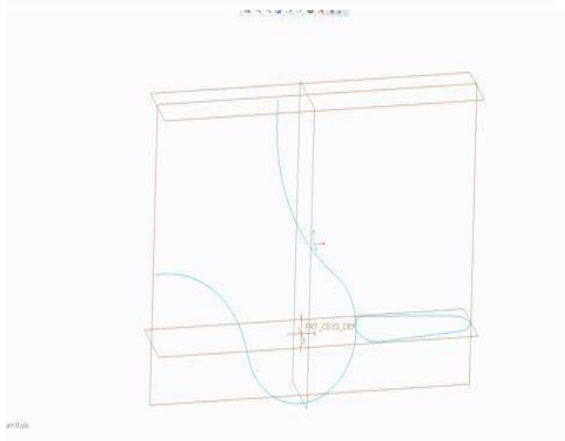
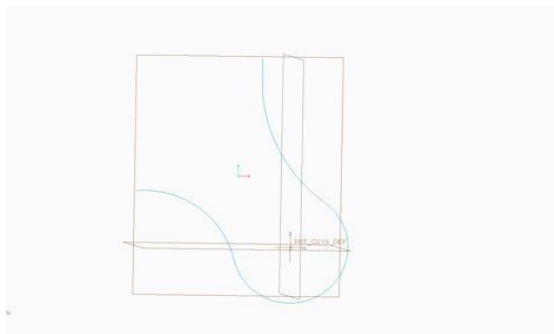

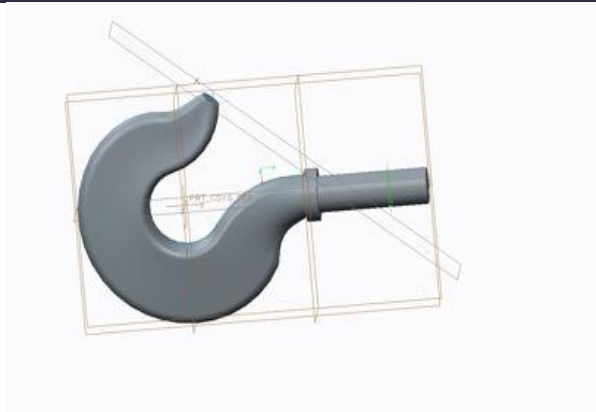

## Material selection

### Steel

Steel is an alloy of iron and carbon and other elements. Because of its high tensile strength and low cost, it is a major component used in buildings, infrastructure, tools, ships, automobiles, machines, appliances, and weapons.

Iron is the base metal of steel. Iron is able to take on two crystalline forms (allotropic forms), body centered cubic (BCC) and face centered cubic (FCC), depending on its temperature. In the body-centred cubic arrangement, there is an iron atom in the centre of each cube, and in the face-centred cubic, there is one at the center of each of the six faces of the cube. It is the interaction of the allotropes of iron with the alloying elements, primarily carbon, that gives steel and cast iron their range of unique properties.

In pure iron, the crystal structure has relatively little resistance to the iron atoms slipping past one another, and so pure iron is quite ductile, or soft and easily formed. In

steel, small amounts of carbon, other elements, and inclusions within the iron act as hardening agents that prevent the movement of dislocations that are common in the crystal lattices of iron atoms.

The carbon in typical steel alloys may contribute up to 2.14% of its weight. Varying the amount of carbon and many other alloying elements, as well as controlling their chemical and physical makeup in the final steel (either as solute elements, or as precipitated phases), slows the movement of those dislocations that make pure iron ductile, and thus controls and enhances its qualities. These qualities include such things as the hardness, quenching behavior, need for annealing, tempering behavior, yield strength, and tensile strength of the resulting steel. The increase in steel's strength compared to pure iron is possible only by reducing iron's ductility.

Steel was produced in bloomery furnaces for thousands of years, but its large-scale, industrial use began only after more efficient production methods were devised in the 17th century, with the production of blister steel and then crucible steel. With the invention of the Bessemer process in the mid-19th century, a new era of mass-produced steel began. This was followed by the Siemens-Martin process and then the Gilchrist-Thomas process that refined the quality of steel. With their introductions, mild steel replaced wrought iron.

Further refinements in the process, such as basic oxygen steelmaking (BOS),

largely replaced earlier methods by further lowering the cost of production and increasing the quality of the final product. Today, steel is one of the most common man-made materials in the world, with more than 1.6 billion tons produced annually. Modern steel is generally identified by various grades defined by assorted standards organizations.

## Heat treatment

There are many types of heat treating processes available to steel. The most common are annealing, quenching, and tempering. Heat treatment is effective on compositions above the eutectoid composition (hypereutectoid) of 0.8% carbon. Hypoeutectoid steel does not benefit from heat treatment.

Annealing is the process of heating the steel to a sufficiently high temperature to relieve local internal stresses. It does not create a general softening of the product but only locally relieves strains and stresses locked up within the material. Annealing goes through three phases: recovery, recrystallization, and grain growth. The temperature required to anneal a particular steel depends on the type of annealing to be achieved and the alloying constituents.

Quenching involves heating the steel to create the austenite phase then quenching it in water or oil. This rapid cooling results in a hard but brittle martensitic structure. The steel is then tempered, which is just a specialized type of annealing, to reduce brittleness. In this application the

annealing (tempering) process transforms some of the martensite into cementite, or spheroidite and hence it reduces the internal stresses and defects. The result is a more ductile and fracture-resistant steel

## Carbon steel

Carbon steel is a steel with carbon content up to 2.1% by weight. The definition of carbon steel from the American Iron and Steel Institute (AISI) states:

- no minimum content is specified or required for chromium, cobalt, molybdenum, nickel, niobium, titanium, tungsten, vanadium, zirconium, or any other element to be added to obtain a desired alloying effect;
- the specified minimum for copper does not exceed 0.40 percent;
- or the maximum content specified for any of the following elements does not exceed the percentages noted: manganese 1.65, silicon 0.60, copper 0.60

The term "carbon steel" may also be used in reference to steel which is not stainless steel; in this use carbon steel may include alloy steels. High carbon steel has many different uses such as milling machines, cutting tools (such as chisels) and high strength wires. These applications require a much finer microstructure, which improves the toughness.

As the carbon percentage content rises, steel has the ability to become harder and stronger through heat

treating; however, it becomes less ductile. Regardless of the heat treatment, a higher carbon content reduces weldability. In carbon steels, the higher carbon content lowers the melting point

## Mild or low-carbon steel

Mild steel (iron containing a small percentage of carbon, strong and tough but not readily tempered), also known as plain-carbon steel and low-carbon steel, is now the most common form of steel because its price is relatively low while it provides material properties that are acceptable for many applications. Mild steel contains approximately 0.05–0.30% carbon making it malleable and ductile. Mild steel has a relatively low tensile strength, but it is cheap and easy to form; surface hardness can be increased through carburizing.

In applications where large cross-sections are used to minimize deflection, failure by yield is not a risk so low-carbon steels are the best choice, for example as structural steel. The density of mild steel is approximately  $7.85 \text{ g/cm}^3$  ( $7850 \text{ kg/m}^3$  or  $0.284 \text{ lb/in}^3$ ) and the Young's modulus is 200 GPa (29,000 ksi).

Low-carbon steels display *yield-point runoff* where the material has two yield points. The first yield point (or upper yield point) is higher than the second and the yield drops dramatically after the upper yield point. If a low-carbon steel is only stressed to some point between the upper and lower yield point then the surface develops Lüderbands. Low-carbon steels contain less carbon than other steels and are

easier to cold-form, making them easier to handle

## Heat treatment

The purpose of heat treating carbon steel is to change the mechanical properties of steel, usually ductility, hardness, yield strength, or impact resistance. Note that the electrical and thermal conductivity are only slightly altered. As with most strengthening techniques for steel, Young's modulus (elasticity) is unaffected. All treatments of steel trade ductility for increased strength and vice versa. Iron has a higher solubility for carbon in the austenite phase; therefore all heat treatments, except spheroidizing and process annealing, start by heating the steel to a temperature at which the austenitic phase can exist. The steel is then quenched (heat drawn out) at a moderate to low rate allowing carbon to diffuse out of the austenite forming iron-carbide (cementite) and leaving ferrite, or at a high rate, trapping the carbon within the iron thus forming martensite. The rate at which the steel is cooled through the eutectoid temperature (about  $727 \text{ }^\circ\text{C}$ ) affects the rate at which carbon diffuses out of austenite and forms cementite. Generally speaking, cooling swiftly will leave iron carbide finely dispersed and produce a fine grained pearlite and cooling slowly will give a coarser pearlite. Cooling a hypo eutectoid steel (less than 0.77 wt% C) results in a lamellar-pearlitic structure of iron carbide layers with  $\alpha$ -ferrite (nearly pure iron) between. If it is hypereutectoid steel (more

than 0.77 wt% C) then the structure is full pearlite with small grains (larger than the pearlite lamella) of cementite formed on the grain boundaries. A eutectoid steel (0.77% carbon) will have a pearlite structure throughout the grains with no cementite at the boundaries. The relative amounts of constituents are found using the lever rule. The following is a list of the types of heat treatments possible

- **Spheroidizing:** Spheroidite forms when carbon steel is heated to approximately 700 °C for over 30 hours. Spheroidite can form at lower temperatures but the time needed drastically increases, as this is a diffusion-controlled process. The result is a structure of rods or spheres of cementite within primary structure (ferrite or pearlite, depending on which side of the eutectoid you are on). The purpose is to soften higher carbon steels and allow more formability. This is the softest and most ductile form of steel.
- **Full annealing:** Carbon steel is heated to approximately 40 °C above Ac<sub>3</sub> or Ac<sub>m</sub> for 1 hour; this ensures all the ferrite transforms into austenite (although cementite might still exist if the carbon content is greater than the eutectoid). The steel must then be cooled slowly, in the realm of 20 °C (36 °F) per hour. Usually it is just furnace cooled, where the furnace is turned off with the steel still inside. This results in a coarse pearlitic structure, which

means the "bands" of pearlite are thick. Fully annealed steel is soft and ductile, with no internal stresses, which is often necessary for cost-effective forming. Only spheroidized steel is softer and more ductile.

- **Process annealing:** A process used to relieve stress in a cold-worked carbon steel with less than 0.3% C. The steel is usually heated to 550–650 °C for 1 hour, but sometimes temperatures as high as 700 °C. The image rightward shows the area where process annealing occurs.
- **Isothermal annealing:** It is a process in which hypoeutectoid steel is heated above the upper critical temperature. This temperature is maintained for a time and then reduced to below the lower critical temperature and is again maintained. It is then cooled to room temperature. This method eliminates any temperature gradient.
- **Normalizing:** Carbon steel is heated to approximately 55 °C above Ac<sub>3</sub> or Ac<sub>m</sub> for 1 hour; this ensures the steel completely transforms to austenite. The steel is then air-cooled, which is a cooling rate of approximately 38 °C (100 °F) per minute. This results in a fine pearlitic structure, and a more-uniform structure. Normalized steel has a higher strength than annealed steel; it has a relatively high strength and hardness.

- **Quenching:** Carbon steel with at least 0.4 wt% C is heated to normalizing temperatures and then rapidly cooled (quenched) in water, brine, or oil to the critical temperature. The critical temperature is dependent on the carbon content, but as a general rule is lower as the carbon content increases. This results in a martensitic structure; a form of steel that possesses a super-saturated carbon content in a deformed body-centered cubic (BCC) crystalline structure, properly termed body-centered tetragonal (BCT), with much internal stress. Thus quenched steel is extremely hard but brittle, usually too brittle for practical purposes. These internal stresses may cause stress cracks on the surface. Quenched steel is approximately three times harder (four with more carbon) than normalized steel.
- **Martempering (Marquenching):** Martempering is not actually a tempering procedure, hence the term "marquenching". It is a form of isothermal heat treatment applied after an initial quench, typically in a molten salt bath, at a temperature just above the "martensite start temperature". At this temperature, residual stresses within the material are relieved and some bainite may be formed from the retained austenite which did not have time to transform into anything else. In industry, this is a process used to control the ductility and hardness of a material. With longer marquenching, the ductility increases with a minimal loss in strength; the steel is held in this solution until the inner and outer temperatures of the part equalize. Then the steel is cooled at a moderate speed to keep the temperature gradient minimal. Not only does this process reduce internal stresses and stress cracks, but it also increases the impact resistance.
- **Tempering:** This is the most common heat treatment encountered, because the final properties can be precisely determined by the temperature and time of the tempering. Tempering involves reheating quenched steel to a temperature below the eutectoid temperature then cooling. The elevated temperature allows very small amounts of spheroidite to form, which restores ductility, but reduces hardness. Actual temperatures and times are carefully chosen for each composition.
- **Austempering:** The austempering process is the same as martempering, except the quench is interrupted and the steel is held in the molten salt bath at temperatures between 205 °C and 540 °C, and then cooled at a moderate rate. The resulting steel, called bainite, produces an acicular





microstructure in the steel that has great strength (but less than martensite), greater ductility, higher impact resistance, and less distortion than martensite steel. The disadvantage of austempering is it can be used only on a few steels, and it requires a special salt bath.

[5] B. Ross, B. McDonald and S. E. V. Saraf, "Big Blue Goes Down. The Miller Park Crane Accident," *Engineering Failure Analysis*, Vol. 14, No. 6, 2007

## CONCLUSIONS

The model that is created in a CAD Tool called solid works, and also calculate theoretical analysis results stress values, after calculating and designing object material selection were made, both steel and low carbon steel material properties were discussed with their properties

## REFERENCE

[1] ASME Standard B30.2, "Overhead Gantry Cranes (Top Running Bridge, Single or Multiple Girder, Top Running Trolley Hoist)," 2005.

[2] ASME Standard B30.9, "Slings Safety Standard for Cableways, Cranes, Derricks, Hoists, Hooks, Jacks and Slings," 2006.

[3] ASME Standard B30.10, "Hooks Safety Standard for Cableways, Cranes, Derricks, Hoists, Hooks, Jacks and Slings," 2009.

[4] Department of Labour of New Zealand, "Approved Code of Practice for Cranes," 3rd Edition, 2009.