



International Journal for Innovative Engineering and Management Research

A Peer Reviewed Open Access International Journal

www.ijiemr.org

COPY RIGHT

2017 IJIEMR. Personal use of this material is permitted. Permission from IJIEMR must be obtained for all other uses, in any current or future media, including reprinting/republishing this material for advertising or promotional purposes, creating new collective works, for resale or redistribution to servers or lists, or reuse of any copyrighted component of this work in other works. No Reprint should be done to this paper, all copy right is authenticated to Paper Authors

IJIEMR Transactions, online available on 19 May 2017. Link :

<http://www.ijiemr.org/downloads.php?vol=Volume-6&issue=ISSUE-3>

Title: TRAVOLUTION – AN EMBEDDED SYSTEM FOR DRIVER SAFETY AND SECURITY

Volume o6, Issue 03, Pages: 110 – 119.

Paper Authors

KANDAVALLI HARIKA, S.KISHORE BABU .

Dept of Electronics and Communication Engineering, Vikas College of Engineering & Technology



USE THIS BARCODE TO ACCESS YOUR ONLINE PAPER

To Secure Your Paper As Per **UGC Guidelines** We Are Providing A Electronic Bar Code

TRAVOLUTION – AN EMBEDDED SYSTEM FOR DRIVER SAFETY AND SECURITY

KANDAVALLI HARIKA¹, S.KISHORE BABU²

¹PG Scholar, Electronics and Communication Engineering, Vikas College of Engineering & Technology, Nunna, AP, India.

²Associate Professor, Electronics and Communication Engineering, Vikas College of Engineering & Technology, Nunna, AP, India.

ABSTRACT

Each year, there are thousands of highway deaths and tens of thousands of serious injuries due to “Run-Off-Road” accidents. Everything from simple driver inattentiveness, to fatigue, callousness, to drunk driving, is responsible. Simple sensors can be fitted inside the vehicles embedded with various features like, automatic collision notification, vehicle security, which can give impetus to an efficient road safety system. Features that are proposed in this work are: Automatic collision notification that gives notification to the victim’s relative, Alcohol detection detects drunk driving, Special zone indications, obstacle and lane detection alerts and vehicle security is used to prevent theft. Road traffic crashes are one of the world’s largest public health and injury prevention problems. The proposed project tackles a major cause of road accidents such as drunken driving.

1.INTRODUCTION

Road traffic crashes are one of the world’s largest public health and injury prevention problems. According to the World Health Organization (WHO), more than a million people are killed in road accidents, each year, all over the world. A report published by the WHO in 2009 revealed that more people die on roads in India than anywhere else in the world. The statistics

for India are chilling. At least 13 people die every hour in road accidents in the country; the latest report of the National Crime Records Bureau reveals. In 2007, 1.14lakh people in India lost their lives in road mishaps. Poor road infrastructure, failure to comply with speed limits, growing drinking and driving habits are among the main factors contributing to deaths from road crashes[4], WHO said in its report on 'Decade of Action for Road

Safety 2011-2010[1]. Currently Road safety systems are available in high end luxury cars such as Audi, Benz etc; to name a few Example: On Star Corporation provides subscription-based communications, in-vehicle security, hands free calling, turn by-turn navigation, and remote diagnostics systems throughout the United States, Canada and China. A similar service is known as Chevy Star in Latin American markets. It provides some of the features an OEM system has, such as Automatic Crash Response, Stolen Vehicle Tracking, Turn-by-Turn Navigation, and Roadside Assistance. The motivation behind this project is an attempt to make an embedded system which is to bring a positive difference in the field of road safety and road discipline. The project tackles a major cause of road accidents such as drunken driving. The requirement of embedded systems is the need of the hour in developing countries & especially with the grim statistics of our country, the need is imminent. Thus incorporation of these features should be mandatory in all cars in the near future without cutting the customer pockets.

1.1 MOTIVATION

Road fatalities in Europe (E.U. 25) account for 50.000 deaths a year. The

objective of the TRACE project is to deliver a study on road accident causations in Europe by conducting an analysis on existing data sources and also, to examine the socio-economic cost/benefits, up to 2020, to assess potential impact of stand-alone and co-operative intelligent vehicle safety systems in Europe. One of the issues of the European Commission is to reduce the number of road fatalities and severe injuries that occur as a consequence of a crash.

For these reason, car manufacturers have been developing a lot of safety systems with the aim of avoiding or reducing the effects of an impact. Some of these systems act before the crash, some of them absorb part of the energy during the impact, and a few try to optimize the time of medical assistance by informing the emergency units about accidents. TRACE Work Package 6 is tasked with the investigation into the safety functions incorporated into motor vehicles and roadways. Today there is a wide range of safety functions designed specifically for these individual vehicle and roadway types all with the aim of accident preventing or the reduction in the risk of injury in the case of an accident.

This report focused primarily on safety systems for passenger cars. The in-

depth study revealed that, despite safety systems were firstly developed to protect the occupants during the crash, most of the newest and future developments focus their interest on crash avoiding. Then, if an accident occurs, future technologies will also help the injured people having a faster assistance. In the first phases of the project, a number of systems were reviewed for other road user. It is suggested that a further evaluation is carried out for these “other road users” to determine if some systems being developed for passenger cars can successfully be installed into HGV’s & Motorcycles and establish what necessary modifications might be required. By conducting this new evaluation and analysing various accident scenarios these other road users are involved in, the socio-economic benefits of installing these systems can be determined.

1.2 PROBLEM DEFINITION

1.2.1 Existing system

In the past existing systems an alcohol detection and vehicle accident detection system using GPS and GSM modems. The system can be interconnected with the car alarm system and alert the owner on his mobile phone. The Microcontroller processes this information and this processed information is sent to the

user/owner using GSM modem A GSM modem is interfaced to the MCU. The GSM modem sends an SMS to the predefined mobile number and informs about this accident. This enable it to monitor the accident situations and it can immediately alerts the police/ambulance service with the location of accident.

Existing system is an automatic vehicle accident detection system using GPS and GSM modems. The system can be interconnected with the car alarm system and alert the owner on his/her mobile phone. This detection and messaging system is composed of a GPS receiver, Microcontroller and a GSM Modem. GPS Receiver gets the location information from the satellite in the form of latitude and longitude[3]. The Microcontroller processes this information and this processed information is sent to the user/owner using GSM modem. A GSM modem is interfaced to the MCU. The GSM modem sends an SMS to the predefined mobile number and informs about this accident. This enable it to monitor the accident situations and it can immediately alert the police/ambulance service with the location of accident.

The system was built around the AT89S52 micro controller from Atmel. This micro controller provides all the

functionality of the SMS alert system. It also takes care of filtering of the signals at the inputs. The uniqueness of this project is not only alerting the neighbours by its buzzer, but also it sends a caution SMS to stored mobile numbers.

1.2.2 Disadvantages in Existing system

1. No sensor to detect while any one tries to steal the vehicle.
2. Doesn't take care of major road accidents.
3. Trunken driving is not considered.

1.2.3 Proposed System

When driver starting car/vehicle then alcohol sensor start sensing at condition vehicle speed equal to zero. If alcoholic driver detected then immediately ignition system will turn off along with SMS about detection is send to relevant of driver for notification and notification will be displayed on LCD with buzzer. A flag is set when first condition is passed without detection of alcohol. If alcohol detected in this case then signal is send to fuel blocker by microcontroller for blocking fuel supply to ignition system. so driver feel's that vehicle is going to stop and then place car at appropriate location .At the same time SMS with current location of vehicle ,vehicle number and detected information

send to relative of driver and police station. Obstacle sensor sense whether any obstacle in front as well as in back of driver and if any then notify using buzzer and display on driver. If Relay is ON then it is detected as collision that will be notify to police (RTO). In other hand, when police station/RTO office received message then they will track car to identify driver. Here we present an automatic vehicle accident detection system using MEMS Sensors, and the information, along with the longitude and latitude details were sent using the GPS and GSM modems. The system can be interconnected with the Alcohol detection, and alert the owner or concerned authorities. This detection and messaging system is composed of a GPS receiver, Microcontroller and a GSM Modem. GPS Receiver gets the location information from satellites in the form of latitude and longitude. The vehicle security is enhanced as all the features are embedded in it. We also have few relays to stop the car, to slow down the car and also to stop the horn.

1.3 OBJECTIVE OF THE PROJECT

The project tackles some major causes of road accidents such as auto breaking

traffic signals and drunken driving[5]. It also has a major objective of exercising road discipline such as lane lines detection. Some of the features are obstacle detection, Vehicle Security, Alcohol detection.

2. PROPOSED SYSTEM

In this project ARM7 is the heart of our project. In this ARM7 LPC2148 is used in this project. To this microcontroller different types of sensors are fitted. Those sensors are ultrasonic sensor, alcohol sensor, lane sensor, MEMS sensors are fitted to this microcontroller. The project tackles some major causes of road accidents such as breaking traffic signals and drunken driving. It also has a major objective of exercising road discipline such as lane lines detection. Some of the features are obstacle detection-In this feature, when the vehicle comes towards our car, then it alerts the driver by using buzzer. And it is also displayed on the LCD. Automatic Collision Notification- In this feature when vehicle meet with an accident, the system of this project sends messages (SMS) via GSM Modem to control room and the nearest relative of the victim. Vehicle security- In this feature, if the vehicle is stolen or someone tries to break in, theft sensor is activated

and message is sent to the police control room and to the owner. The alcohol sensor prevents the ignition key from working if the driver breathes into it and a significant quantity of alcohol is detected. Consequently message is sent to the relative members. GPS is used to track the vehicle. When vehicle is theft then it tracks the position of the vehicle and it sends the SMS to the relative numbers by using GSM. Relay, if it is used to ON and OFF the motor. When driver consume the alcohol then it stops the vehicle by using the relay and when vehicle cross the lane lines then vehicle speed is reduced by using the relay.

LCD is used to displays the outputs when driver is inattentiveness. LCD's are used in a wide range of applications including computer monitors, instruments.

2.2 BLOCK DIAGRAM

ARM7 is one of the widely used microcontroller family in embedded system application. ARM is a family of instruction set architectures for computer processors based on a reduced instruction set computing (RISC) architecture developed by british company ARM holdings.

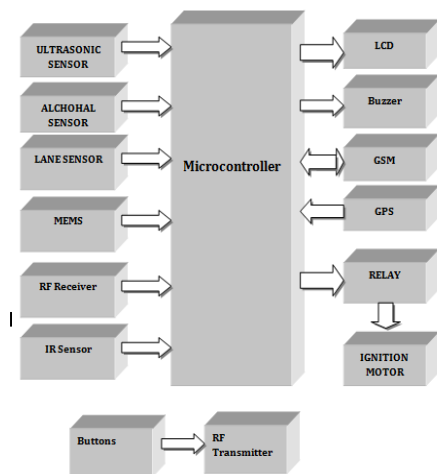

Fig 2.1:Block Diagram

3. HARDWARE DESIGN

3.1 INTRODUCTION

In this project the ARM 7 microcontroller is used to interface with peripheral devices. GSM module is used for generating message. The GSM module is connected to ARM 7 directly. Here also connected the GPS to track the location of the vehicle.

3.2 SCHEMATIC DIAGRAM

The schematic diagram of “A Novel E-Solution System for Vehicle Accidents” is shown in Fig.3.1

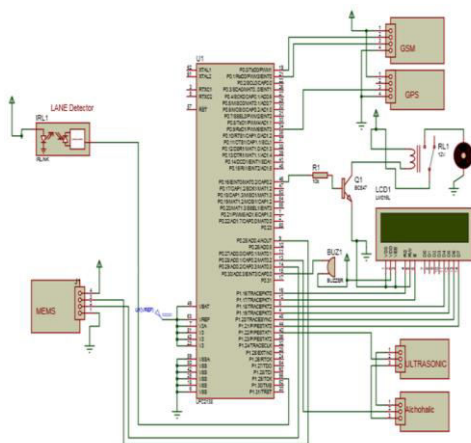

Fig 3.1:Schematic Diagram

The heart of our project is LPC2148 and here LPC means Linearly Programmable Control. It consists of 64 pins and those 64 pins are divided into two ports. They are port 0 (P0) and port 1 (P1). Port 0 consists of 32 pins i.e., P0.0 to P0.31 in these 32 pins pin no. 24,26,27 are not used, so the overall available pins in port 0 are 29. Port 1 consists of 32 pins i.e., P1.0 to P1.31. in these 32 pins P1.0 to P1.15 are not used, so the remaining pins in port 1 are P0.16 to P1.31 overall 16 pins. Therefore the overall pins available in ARM 7 are 45. These 45 pins act as the input-output pins of ARM 7. These are bidirectional and used for multipurpose. And coming to the operating voltage ARM 7 requires 3.3V. It consists of 4 VCC pins(7,23,43,51), 6 GND pins(6,18,25,42,50,59) and 10 ADC pins. ARM 7 consists of 5 major important registers.

Coming to the power supply, 230V AC power supply will be reduced to 12V AC with the transformer. The output of the transformer (12V AC) will be given to rectifier IN4007. The output of rectifier will be pulsating DC and it is fed to the filter which consists of 100µf capacitor, and it converts the pulsating DC to the pure DC. This pure DC voltage is given to the regulator 7805; it converts the 12V DC to 5V DC. Regulator is used to adjust the

voltage. As ARM 7 requires only 3.3V, we use LM117 regulator to convert 5V DC to the 3.3V DC. While we are executing a program which is written in LPC2148, it doesn't know where to end the line and in order to tell the Micro Processor about the line by line execution we use crystal oscillator. The signals in the crystal oscillator are in the form of pulses. So the completion of one complete pulse indicates the Micro Processor to go to the next line. The speed of the operation depends on crystal and its operating range is 12MHz.

The outputs of these various sensors will either be in analog or digital form. But as we giving the output of these sensors to ARM7, it only allows the input in the form of digital. So in order to convert the analog to digital we use ADC which is present in built in ARM7.

4. FLOW CHART

The flow chart shown in the above Fig.4.1 start by initializing the Program. Read all the sensor values .Those values will be displayed on the LCD. Initially we create some threshold value. If any parameter value crosses the threshold level the buzzer will indicates the alarm. If any theft happened, then immediately the information will be sent to

owner.

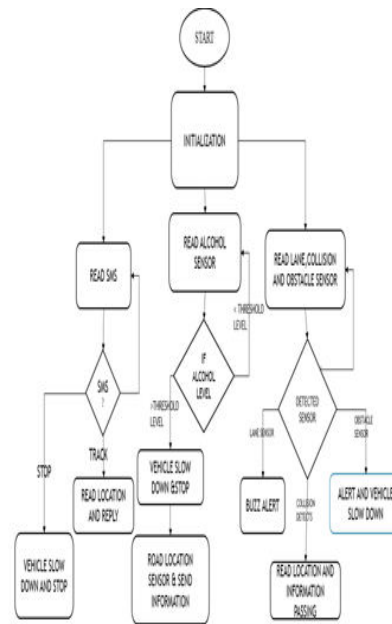

Fig. 4.1: Flowchart

5. SOFTWARE TOOLS

In this project the implementation is done by using different software's like:

- Keil μ Vision IDE
 - Editor
 - Compiler
 - Debugger
 - Converter
 - Proteus
 - Schematic design
 - Simulation
 - Layout design
- * Flash magic Used for dumping purpose

6. RESULTS

6.1 EXPERIMENTAL SETUP

In this chapter we will discuss the experimental setup. Here the below figure shows result after dumping of code into the microcontroller through flash magic software. Outcome, consequence, or conclusion of a problem, probe or experiment after a period of time is called Result. The length of time taken to find a result can vary from less than a second to many years or it is also defined as data received after processing a query. This experimental setup discusses about how various components are connected to the board. It is shown in the below Fig.6.1

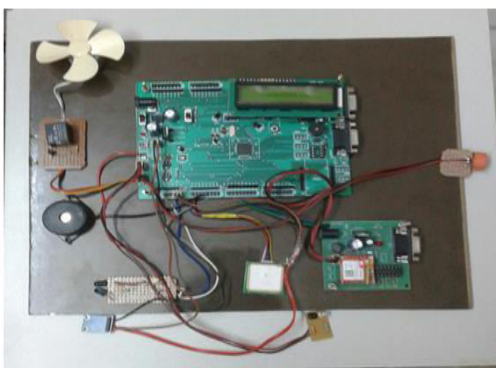

Fig 6.1:Result of the project

In this, the output can be observed that the various components are connected to the board. Then after fixing all the components we have to generate the code for the corresponding components. We have to connect the adaptor to the kit this means that we are giving the power supply. Next switch on the kit and press the reset button and after pressing the reset

button code starts initialized and this will be shown on the LCD.

6.2 RESULT ANALYSIS

Collision Detection

For the collision detection ultrasonic sensor is used .Switch has “ON” and “OFF” condition .If any obstacle near by the vehicle then it sends the “SMS” to the nearer relative numbers , as in Fig.6.2



Car Theft Identification: A system operation is triggered when a limit switch is tripped . When the limit switch is pressed, theft alert is displayed on the LCD screen and SMS along with location of toy car is given to the number that is pre fed via GSM Modem. In real life SMS would be sent to the owner of the vehicle along with the location of the car, as in Fig.6.3

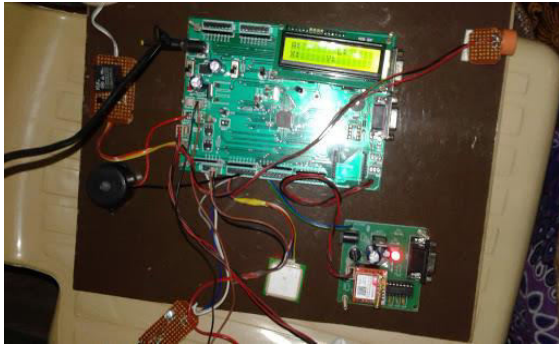

Fig.6.3: Theft detection Condition

Alcohol Detection

To test this feature, the MQ3 alcohol sensor is being exposed to a liquid solution that has 30% or more alcohol content in it. If detected, the buzzer rings, the car comes to a halt and “SMS to R.T.O “is displayed on the LCD screen. The SMS is sent to the number pre fed for this feature via GSM. “Alcohol Sensed” message is also displayed on the LCD, as in Fig.6.4

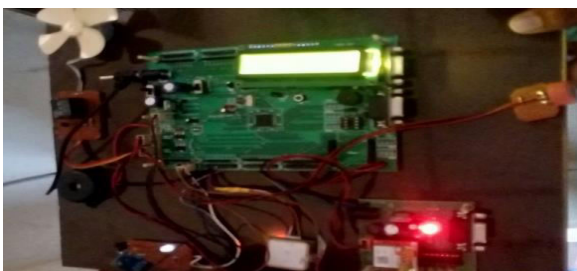

Fig.6.4:Alcohol Detection Condition

Lane Sensor

If vehicle cross the lane lines then it sends the message and it can be displayed on then LCD,And also vehicle speed is reduced, as in Fig.6.5



Fig.6.5: Lane Detection

MEMS Sensor

If Accident occurred then it sends the SMS to the relative numbers and it can be displayed on the LCD and also TRACK the vehicle location by using GPS, And sends the SMS by using the GSM, as in Fig.6.6



Fig.6.6: MEMS

7.CONCLUSION

With this prototype, a cost effective embedded system has been successfully implemented which helps in curbing road accidents and also providing security for the vehicle.

8.FUTURE SCOPE

In future, By adding more sensors it can be measured various parameters of the road accidents like horn control of vehicle in no honking zone and also red light traffic control. This Project can be applicable for upcoming technologies like IoT.

REFERENCES

- [1]. Amiya kumar tripathy,sejal chopra,"Travolution-An Embedded System in Passenger Car for Road Safety",ICTSD-2015,Feb.04-06,2015.
- [2]. Benliang Li,Houjun Wang,Bin yan and Chijun Zhang,"The Research of applying wireless sensor networks to Intelligent Transportation System IT Based on IEEE 802.15.4", 6th international Conference on ITS Telecommunication Proceedings,pp.939-942,2006.
- [3]. Y.Cui and S.S.Gee , "autonomous vehicle positioning with GPS in urban canyon environments; IEEE Transaction on Robotics and Automation", vol.19,pp.110,1 February2003.
- [4]. Samer Ammoun , Fawzi Nashashibi, Claude Laugeau, "Real-time crash avoidance system on crossroads based on 802.11 devices and GPS receivers; in proceedings of the IEEE ITSC 2006, IEEE Intelligent Transportation system Conference Toronto", Canada, September 2006.
- [5]. Fabrication of auto breaking system for pre crash safety using sensor,Eung sookim,IJCA,Volume 2,No:1 march,2009.
- [6]<http://www.engineersgarage.com/electronic-components/ht12e>.
- [7]<http://www.sproboticworks.com/products/gsm-gps/sim-300-module.html> .
- [8]<https://www.sparkfun.com/products/88>
- [9]http://www.allaboutcircuits.com/vol_4/chpt_5/2.html .
- [10]<http://www.engineersgarage.com/tutorials/89s51-89s52-programmerbasics>.
- [11]http://www.rhydolabz.com/documents/gps_gsm/GPS1269_UserManual.pdf .
- [12]<http://en.wikipedia.org/wiki/MAX232>.