



# International Journal for Innovative Engineering and Management Research

A Peer Reviewed Open Access International Journal

www.ijiemr.org

**COPY RIGHT**



**ELSEVIER**  
**SSRN**

**2018 IJIEMR.** Personal use of this material is permitted. Permission from IJIEMR must be obtained for all other uses, in any current or future media, including reprinting/republishing this material for advertising or promotional purposes, creating new collective works, for resale or redistribution to servers or lists, or reuse of any copyrighted component of this work in other works. No Reprint should be done to this paper, all copy right is authenticated to Paper Authors

IJIEMR Transactions, online available on 13th Jan 2018. Link

[:http://www.ijiemr.org/downloads.php?vol=Volume-07&issue=ISSUE-01](http://www.ijiemr.org/downloads.php?vol=Volume-07&issue=ISSUE-01)

Title: **ANALYSIS OF SWITCHED-CAPACITOR TECHNIQUES FOR RENEWABLE ENERGY SYSTEM APPLICATIONS**

Volume 07, Issue 01, Pages: 447-452.

Paper Authors

**DR. A. V SUDHAKARA REDDY**



USE THIS BARCODE TO ACCESS YOUR ONLINE PAPER

To Secure Your Paper As Per **UGC Guidelines** We Are Providing A Electronic Bar Code



## ANALYSIS OF SWITCHED-CAPACITOR TECHNIQUES FOR RENEWABLE ENERGY SYSTEM APPLICATIONS

DR. A. V SUDHAKARA REDDY

Department of Electrical and Electronics Engineering, MALLA REDDY ENGINEERING COLLEGE  
(Autonomous)

### ABSTRACT

This paper presents a new high step-up dc/dc converter for renewable energy systems in which a high voltage gain is provided by using a coupled inductor. The operation of the proposed converter is based on a charging capacitor with a single power switch in its structure. A passive clamp circuit composed of capacitors and diodes is employed in the proposed converter for lowering the voltage stress on the power switch as well as increasing the voltage gain of the converter. Since the voltage stress is low in the provided topology, a switch with a small ON-state resistance can be used. As a result, the losses are decreased and the efficiency is increased. Therefore, a main power switch with low resistance  $R_{DS(ON)}$  can be used to reduce the conduction losses. The operation principle and the steady-state analyses are discussed thoroughly. To verify the performance of the presented converter, a 300W laboratory prototype circuit is implemented. The results validate the theoretical analyses and the practicability of the presented high step-up converter.

### 1. INTRODUCTION

Demand for clean and sustainable energy sources has dramatically increased during the past few years with growing population and industrial development. For a long time, fossil fuels have been used as the major source of generating electrical energy. Environmental consequences of these resources have made it necessary to benefit from clean energy sources such as wind and solar. Therefore, distributed generation (DG) systems based on renewable energy sources have attracted the researchers' attention. The DG systems include

photovoltaic (PV) cells, fuel cells and wind power [1]- [3]. However, the output voltages of these sources are not large enough for connecting to ac utility voltage. PV cells can be connected in series in order to obtain a large dc voltage. However, it is difficult to ignore the shadow effect in PV panels [4]. High step-up converters are a suitable solution for the aforementioned problem. Each PV panel can be connected to a particular high step-up converter. Therefore, each panel can be controlled independently. These converters boost the low input voltages



(24-40 V) to a high voltage level (300-400 V). The main features of high step-up converters are their large conversion ratio, high efficiency and small size.

Theoretically, conventional boost converters can achieve high voltage gain with an extremely high duty ratio. However, the performance of the system will be deteriorated with a high duty cycle due to several problems such as low conversion efficiency, reverse-recovery and electromagnetic interference problems. Some transformer-based converters like forward, push-pull or flyback converters can achieve high step-up voltage gain by adjusting the turn ratio of the transformer. However, the leakage inductor of the transformer will cause serious problems such as voltage spike on the main switch and high power dissipation. In order to improve the conversion efficiency and obtain high step-up voltage gain, many converter structures have been presented. Switched capacitor and voltage lift techniques have been used widely to achieve high step-up voltage gain. However, in these structures, high charging currents will flow through the main switch and increase the conduction losses. Coupled-inductor based converters can also achieve high step-up voltage gain by adjusting the turn ratios. However, the energy stored in the leakage inductor causes a voltage spike on the main switch and deteriorates the conversion efficiency. To overcome this problem, coupled inductor based converters with an active-clamp circuit have been presented. Some high step-up

converters with two-switch and single-switch are introduced in the recent published literatures. However, the conversion ratio is not large enough.

In order to save the natural environment of the earth, the development of clean pollution free energy has had a major role in the last decade [1]. For dealing with the issue of global warming, clean energies, such as fuel cells (FC), photovoltaic (PV) sources, wind energy, etc., have been rapidly promoted [2], [3]. Generally, the maximum power point (MPP) voltage of a typical PV panel is in the range of 15-40 V depending on the power capacity of the PV panel [4]. Thus, a high voltage gain converter is required to obtain a high output voltage from a low input voltage, especially in grid connected applications. Conventional boost and buck-boost converters can be used to provide a high output voltage. However, they must work with an extremely high duty cycle. This is limited due to a number of issues such as the impact of the power switches, the diodes, and the equivalent series resistances (ESR) of the inductors and capacitors. Moreover, its control and stability at high duty cycles is very complex. One solution is utilizing flyback converters. However, the transformers used in this kind of converter increase the cost, the size and the voltage stress on main switch, and the leakage losses become large. The use of active-clamps and resistor-capacitor-diodes (RCD) can largely eliminate these problems, but they are not very economic due to the high

power switch driver circuit. In high-voltage transformers with a very high turns ratio, the characteristics of non-ideal elements are getting worse and worse. Therefore, the leakage inductance of the

transformer results in an adverse voltage spike. As a result, the circuit elements experience failure. In addition, the distribution capacitors of the transformers cause current spikes. Both of these non-ideal features increase the switching losses and decrease the efficiency of the converter. Several converters with a high voltage gain have been proposed. Coupled inductors are used to get a high voltage gain in non-isolated converters. The main problem with these kinds of converters is the leakage inductance of the coupled inductor, which increases the voltage stress on the main switch.

## 2. OPERATING PRINCIPLE OF THE PROPOSED CONVERTER

The circuit configuration of the proposed converter is shown in Fig. 1. The proposed converter comprises a DC input voltage ( $V_i$ ), active power switch (S), coupled inductor, four diodes and four capacitors. Capacitor C1 and diode D1 are employed as clamp circuit respectively. The capacitor C3 is employed as the capacitor of the extended voltage multiplier cell. The capacitor C2 and diode D2 are the circuit elements of the voltage multiplier which increase the voltage of clamping capacitor C1. The coupled inductor is modeled as an ideal transformer with a

turn ratio  $N$  ( $N_p/N_s$ ), a magnetizing inductor  $L_m$  and leakage inductor  $L_k$ .

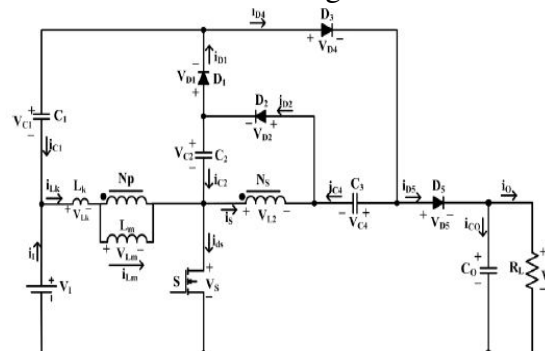

Fig. 1. Circuit configuration of the presented high step-up converter.

In order to simplify the circuit analysis of the converter, some assumptions are considered as follow: 1) All Capacitors are sufficiently large. Therefore  $V_{C1}$ ,  $V_{C2}$ ,  $V_{C3}$ , and  $V_O$  are considered to be constant during one switching period.

2) All components are ideal but the leakage inductance of the coupled inductor is considered.

According to the aforementioned assumptions, the CCM operation of the proposed converter includes five intervals in one switching period. The current-flow path of the proposed converter for each stage is depicted in Fig. 2. Some typical waveforms under continuous conduction mode (CCM) operation are illustrated in Fig. 3. The operating stages are explained as follows.

1) *Stage I* [ $t_0 < t < t_1$  see Fig. 2(a)]: In this stage, switch S is turned on. Also, diodes D2 and D4 are turned on and diodes D1, D3 are turned off. The DC source ( $V_i$ ) magnetizes  $L_m$  through S. The secondary-side of the coupled

inductor is in parallel with capacitor C2 using diode D2. As the current of the leakage inductor Lk increases linearly, the secondary-side current of the coupled inductor ( $i_S$ ) decreases linearly. The required energy of load (RL) is supplied by the output capacitor CO. This interval ends when the secondary-side current of the coupled inductor becomes zero at  $t=t_1$ .

2) *Stage II* [ $t_1 < t < t_2$  see Fig. 2(b)]: In this stage, switch S and diode D3 are turned on and diodes D1, D2 and D4 are turned off. The DC source VI magnetizes Lm through switch S. So, the current of the leakage inductor Lk and magnetizing inductor Lm increase linearly. The capacitor C3 is charged by dc source VI, clamp capacitor and the secondary-side of the coupled inductor. Output capacitor CO supplies the demanded energy of the load RL. This interval ends when switch (S) is turned off at  $t=t_2$ .

3) *Stage III* [ $t_2 < t < t_3$  see Fig. 2(c)]: In this stage, switch S is turned off. Diodes D1 and D3 are turned on and diodes D2 and D4 are turned off. The clamp capacitor C1 is charged by the stored energy in capacitor C2 and the energies of leakage inductor Lk and magnetizing inductor Lm. The currents of the secondary-side of the coupled inductor ( $i_S$ ) and the leakage inductor are increased and decreased respectively. The capacitor C3 is still charged through D3. Output capacitor CO supplies the energy to load RL. This interval ends when  $i_{Lk}$  is equal to  $i_{Lm}$  at  $t=t_3$ .

4) *Stage IV* [ $t_3 < t < t_4$  see Fig. 2(d)]: In this stage, S is turned off. Diodes D1 and D4 are turned on and diodes D2 and D3 are turned off. The clamp capacitor C1 is charged by the capacitor C2 and the energies of leakage inductor Lk and magnetizing inductor Lm. The currents of the leakage inductor Lk and magnetizing inductor Lm decrease linearly. Also, a part of the energy stored in Lm is transferred to the secondary side of the coupled inductor. The dc source VI, capacitor C3 and both sides of the coupled inductor charge output capacitor and provide energy to the load RL. This interval ends when diode D1 is turned off at  $t=t_4$ .

5) *Stage V* [ $t_4 < t < t_5$  see Fig. 2(e)]: In this stage, S is turned off. Diodes D2 and D4 are turned on and diodes D1 and D3 are turned off. The currents of the leakage inductor Lk and magnetizing inductor Lm decrease linearly. Apart of stored energy in Lm is transferred to the secondary side of the coupled inductor in order to charge the capacitor C2 through diode D2. In this interval the DC input voltage VI and stored energy in the capacitor C3 and inductances of both sides of the coupled inductor charge the output capacitor Co and provide the demand energy of the load RL. This interval ends when switch S is turned on at  $t=t_5$ .

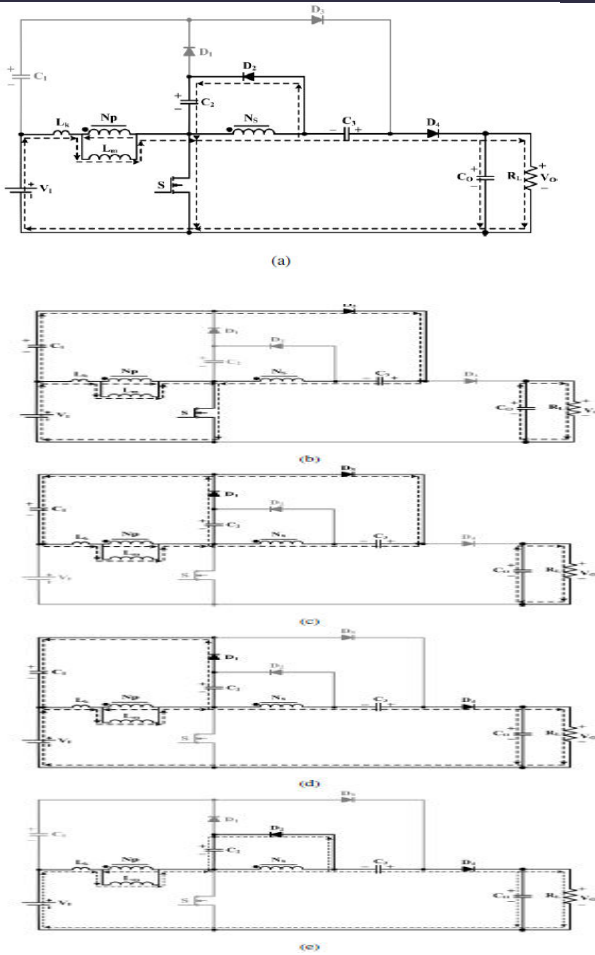

Fig. 2. Current-flow path of operating modes during one switching period at CCM operation. (a) Mode I. (b) Mode II. (c) Mode III. (d) Mode IV. (e) Mode V.

### 3. CAPACITORS AND INDUCTANCE

The magnetizing inductance of the coupled inductor is designed according to (28) and (29). To assure the CCM operation of the presented converter, the value of more than  $L_m B$ . Therefore, the minimum value of the magnetizing inductance can be calculated as follows:

$$L_{min} = \frac{D(1-D)^2 R_L}{8f_s (n^2(1+D) + n(3+D) + 1)}$$

According to (30), the magnetizing inductance should be more than  $148\mu H$ . A coupled inductor with the magnetizing inductance of the  $300\mu H$  is employed to guarantee the CCM operation of the implemented converter. In order to design the size of the capacitors, it should be followed four conditions regarding the ripple in the output voltage. The conditions are ripple of the capacitor current, ripple due to the equivalent series resistance (ESR) of the capacitor, ripple due to the equivalent series inductance (ESL) of the capacitor, and the hold-up time requirement for load step response which the last condition is for the output capacitor. First, the design is started by considering only the first condition which ESRs and ESLs are not known before selecting the capacitor. Then, ESRs and ESLs are obtained from the capacitors' datasheets. The total output voltage ripple is checked to make sure that it is below the admissible value by considering ESRs and ESLs. In addition, the ripple of the capacitor currents are calculated and compared to the value mentioned in datasheet to make sure that the selected capacitors are in consistent with the practical conditions. In order to calculate the voltage ripple of a capacitor ESR and ESL, the following equation is used.

$$V_c(t) = V_c(t_0) + \frac{1}{C} \int_{t_0}^t i(t) dt$$

Since the average currents through capacitors C1, C2, C3 and CO are zero

under steady state, the average current values of diodes are equal to  $I_O$

## CONCLUSION

In this paper, a new structure for a high step-up dc/dc boost converter was proposed. In the proposed structure, high voltage gains with low duty cycles are achieved by using capacitors charging techniques and various turn ratios. A comparative study with other similar converters highlights the merits of the proposed topology. In the proposed converter, to eliminate voltage spikes on the main switch, a passive voltage clamp circuit is used. Due to the low voltage stress, low ON-state resistance devices can be used, which increases the efficiency. By recycling the energy of the leakage inductances, the losses are reduced and the efficiency is increased. To confirm the correct performance of the proposed converter, several simulation and experimental results have been presented.

## REFERENCES

- [1] A. Kirubakaran, S. Jain, and R. K. Nema, "DSP-controlled power electronic interface for fuel-cell-based distributed generation," *IEEE Trans. Power Electron.*, Vol. 26, No. 12, pp. 3853-3864, Dec. 2011.
- [2] M. Moradzadeh, S. Hamkari, E. Zamiri, and R. Barzegarkhoo, "Novel high step-up DC/DC converter structure using a coupled inductor with minimal voltage stress on the main switch," *Journal of Power Electronics*, Vol. 16, No.6, pp. 2005-2015, Nov. 2016.
- [3] Barzegarkhoo, R., Zamiri, E., Moradzadeh, M., & Shadabi, H. "Symmetric hybridised design for a novel step-up 19-level inverter," *IET Power Electron.*, Vol. 10, No. 11, pp. 1241-1249, Sep. 2017.
- [4] S. M. Chen, T. J. Liang, L. S. Yang, and J. F. Chen, "A boost converter with capacitor multiplier and coupled inductor for ac module applications," *IEEE Trans. Ind. Electron.*, Vol. 53, No. 1, pp. 1503-1511, Apr. 2013.
- [5] B. Liu, S. Duan, and T. Cai, "Photovoltaic dc-building-module-based BIPV system – Concept and design considerations," *IEEE Trans. Power Electron.*, Vol. 26, No. 5, pp. 1418-1429, May 2011.