

# International Journal for Innovative Engineering and Management Research

A Peer Reviewed Open Access International Journal

[www.ijiemr.org](http://www.ijiemr.org)

## COPY RIGHT



**ELSEVIER**  
**SSRN**

**2020 IJIEMR.** Personal use of this material is permitted. Permission from IJIEMR must

be obtained for all other uses, in any current or future media, including reprinting/republishing this material for advertising or promotional purposes, creating new collective works, for resale or redistribution to servers or lists, or reuse of any copyrighted component of this work in other works. No Reprint should be done to this paper, all copy right is authenticated to Paper Authors

IJIEMR Transactions, online available on 4th Jan 2020. Link : [www.ijiemr.org](http://www.ijiemr.org)

Title: **INTEND AND PERFORMANCE OF WIND POWER GENERATION WITH ANN CONTROLLER**

Volume 09, Issue 01, Pages: 1–8.

Paper Authors

**SABAHUDDIN AHMAD<sup>1</sup>, Dr. SAYANTI CHATTERJEE<sup>2</sup>**



USE THIS BARCODE TO ACCESS YOUR ONLINE PAPER

To Secure Your Paper As Per **UGC Guidelines** We Are Providing A Electronic Bar Code

## INTEND AND PERFORMANCE OF WIND POWER GENERATION WITH ANN CONTROLLER

SABAHUDDIN AHMAD<sup>1</sup>, Dr. SAYANTI CHATTERJEE<sup>2</sup>

<sup>1</sup> P.G. Student, Dept of EEE, Narsimha Reddy Engineering College, Hyderabad, T.S, India.

<sup>2</sup> Professor, Dept of EEE, Narsimha Reddy Engineering College, Hyderabad, T.S, India.

### ABSTRACT:

This research provides 2 techniques to boost the optimal power factor monitoring (MPPT) method for a brand-new wind power system that contains global equipment, 2 irreversible magnet simultaneous makers, as well as tons. The generator, the electrical motor, as well as the wind generator is attached to the sunlight equipment, ring equipment, as well as provider of global equipment, specifically. With the help of an electrical motor, the system could track the optimum power without the full-power converter for generator as a result of its unique operating concept. Traditional maximum torque (COT) control technique with a torque mistake feed onward branch is recommended to acquire faster feedback compared to COT control technique. Furthermore, thinking about that the real power could not get to the academic maximum factor as a result of the loss torque of the system, the COT control with torque loss payment is explained. An approach is additionally suggested to approximate loss torque. Lastly, the academic evaluation is validated by simulation and also experiment outcomes.

**Keywords:** *COT, Maximum power point tracking system, generator, Wind power generation system.*

## 1. INTRODUCTION:

The climbing stress of power situation as well as major setting air pollution caused the raising appeal of wind power conversion system due to the fact that wind is among one of the most crucial all-natural power resources. Wind, as a result of its prospective to give an eco-friendly and also financially affordable methods of electrical power generation, has actually ended up being a quick expanding power resource around the world. In the previous years, research studies have actually been carried out to review the efficient control plans and also to enhance the framework of the wind power conversion system. These research studies target at catching the optimum power from wind, undermine the impact of power change, as well as minimize price.

When it comes to the research study of MPPT control technique, the majority of scholars talked about a number of formulas based upon power signal comments approach. The writers in a previous research study got the power from corrected dc voltage partnership as well as Chen et al. obtained a dc voltage from dc existing partnership. The writers in explained an unique technique utilizing the connection of  $U_2$  as well as  $I_d$ . An additional control formula that does not require popular system qualities is called perturbation as well as monitoring technique. In this technique, the generator rate is managed to the optimal factor by controlling voltage or existing inning accordance with the relative outcomes in between outcome power dimensions. The brand-new framework of wind system has

actually been recommended by scholars in recent times, Kou et alia, showed an unique off-grid wind power generator that contains 2 Y-connected windings established. The writers include mechanical and also electric variable transmission (M-EVT) in between wind generator and also concurrent generator to control regularity as opposed to the converter as well as to maintain the generator straight linked to the grid. Nonetheless, the suggestion requires the full-power M-EVT, which has high-capacity and also causes boosted price as well as setup trouble. The voltage source-based regularity converters have actually restricted overload capacity; Markus et al. presented a brand-new wind generator based upon electromechanical differential systems. The financial facets were assessed, as well as the grid mistake simulation was carried

out.

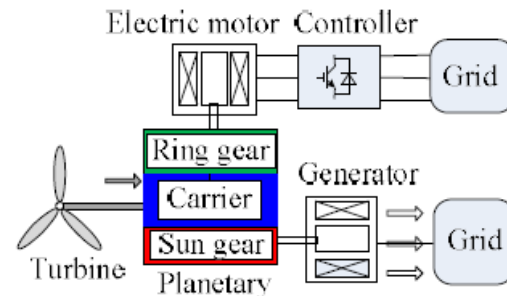

**Fig.1.1. model diagram.**

## 2. RELATED STUDY:

DVG is an abridgment for the Induction Generator, a duration principles traditional planned cyndrical tube. It hinges on an intro generator with multi-stage traumatize blades as well as a multi-stage moving loophole established with scrapes to strike blades curving. It is prospective to evade the multi-phase moving loophole setting up (see Electric Brushless Double Feeding Machines), however accredited are troubles with ability, expense, as well as dimension. A beat replacement is the twin

damages blades smooth feeding maker. The guideline of DVG is that the blades coil identifies to the grid with slip rings as well as a possible beginning generator from closest that controls both the blades as well as the grid trends. Therefore the blades reappearance could differ freely from the chain rep (50 or 60 Hz). Utilizing the generator to regulate the blades trends, it is prospective to fix the vibrant and also running stamina feeding grid of the professional openly of the generator turn quicken. The take care of principle made use of is one to take care of the river dual-axle interaction or overview collar command. The DTK has actually been changed right into a right communication compared to contemporary bearing provide primarily when high trends of the eager beaver are required. The Utilization and also Development of wind power has actually come to be a

vital part of globe lasting power growth. Wind power systems are being strongly researched as a result of its advantages as an atmosphere pleasant as well as lasting resource of power. Because of its unpredictable nature, power implementation principles are needed for removal as much power as feasible from the wind power. In this paper some formulas have actually been reviewed to maintain the system at its greatest feasible lots in all times. The formulas have actually been made use of to acquire the optimum operating factors for transferor optimum power.

### 3. PROPOSED SYSTEM:

Wind energy power generation is one of the most crucial type of the use of wind power. The optimum removal of power from a renewable resource generally depends upon the toughness of the resource in addition to on the operating factor of

the power conversion system. As a result the significance of Maximum Power Point monitoring (MPPT) in renewable resource conversion systems is not just to optimize the system's performance yet likewise to reduce the repayment duration of the setup expense. The generator, the electrical motor, and also the wind generator are attached to the sunlight equipment, ring equipment, as well as provider of global equipment, specifically. With the help of an electrical motor, the system could track the optimum power without the full-power converter for generator as a result of its unique operating concept. Standard maximum torque (COT) control approach with a torque mistake feed ahead branch is suggested to get faster action compared to COT control technique. Additionally, taking into consideration that the real power could not get to the academic optimal

factor because of the loss torque of the system, the COT control with torque loss payment is defined. A technique is additionally recommended to approximate loss torque. Ultimately, the academic evaluation is confirmed by simulation and also experiment outcomes.

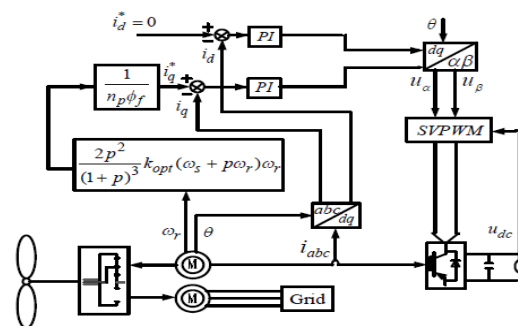

Fig.3.1. simulation model circuit.

#### 4. SIMULATION RESULTS:

For this system, after the generator attaches to the grid, the torque control of electrical motor is triggered to track the maximum power based on the feature of wind turbine when the wind rate is listed below the ranked worth. From the power-speed contour of wind turbine received Fig, each power

contours shows just one top factor under a particular wind rate. This sensation indicates event of an optimal rate under each wind speed. As a result, to appropriately change the wind turbine rate when wind speed differs so about get the optimum power is needed. Mean that the wind generator is running at a consistent factor (A) in Fig. under a particular wind rate  $v_1$ , the matching power is  $P_1$ . The abrupt rise of wind speed to  $v_2$  creates the existing wind resistant power indicates actions up to B. However, as a result of the minute of inertia, the wind turbine rate could not alter right away. To puts it simply, the wind generator power is still at factor A that is smaller sized compared to the wind resistant power at this actual minute. Therefore, the wind turbine will certainly speed up due to the torque distinction (wind resistant torque versus generator torque) till the wind resistant power as

well as wind turbine power both reach factor C.

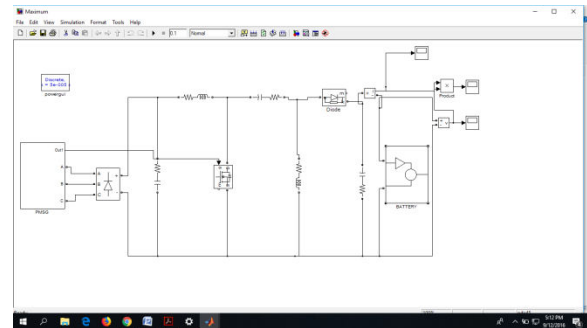

**Fig.4.1. Proposed simulation diagram.**

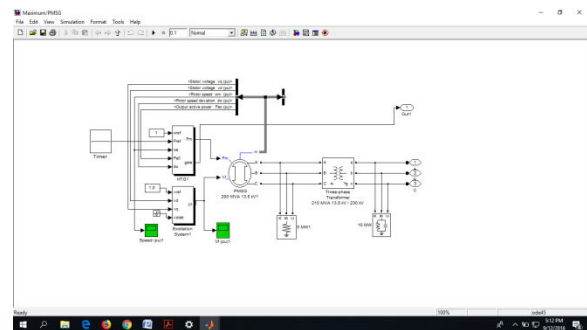

**Fig.4.2. Wind power generation system.**

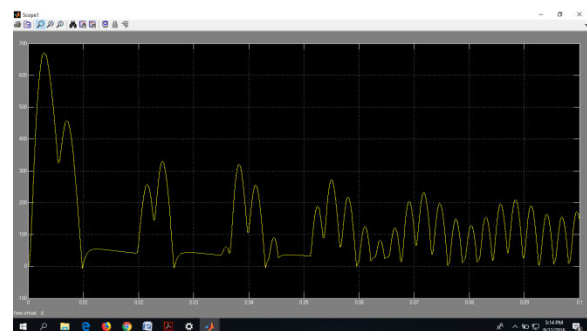

**Fig.4.3. Power across the output.**

## 5. CONCLUSION:

This research study has actually established a MPPT torque control approach for a brand-new wind power system as well as has actually mostly concentrated on boosting this approach to improve capacity in recording wind power. By readjusting the feed-forward coefficient to acquire fast action, the system could track well the variant of wind rate. Nonetheless, it really creates power variations. In addition, the research study results show that the habits of loss torque settlement truly aids making the operating factor near the maximum worth. Therefore, the power manufacturing could be enhanced with the aid of this research study.

## REFERENCES:

- [1] S. M. Barakati, M. Kazerani, as well as J. D. Aplevich, "Maximum tracking control for a wind generator system consisting of a matrix converter," *IEEE Trans. Power Convers.*, vol. 24, no. 99, pp. 705--713, Sep. 2009.
- [2] K. Tan as well as S. Islam, "Optimum control methods in power conversion of PMSG wind generator system without mechanical sensing units," *IEEE Trans. Power Convers.*, vol. 19, no. 2, pp. 392-- 399, Jun. 2004.
- [3] Z. Chen and also E. Spooner, "Grid power top quality with variable rate wind generators," *IEEE Trans. Power Convers.*, vol. 16, no. 2, pp. 148-- 154, Jun. 2001.
- [4] Y. Xia, K. Ahmed, and also B. W. Williams, "Wind power coefficient evaluation of a brand-new optimum power factor monitoring method," *IEEE Trans. Ind. Electron.*, vol. 60, no. 3, pp. 1122-- 1132, Mar. 2013.
- [5] R. Datta and also V. T. Ranganathan, "An approach of tracking the peak power factors for a variable rate wind power conversion system," *IEEE*





Trans. Power Convers., vol. 18, no. 1, pp. 163-- 168, Mar. 2003.

[6] E. Koutroulis as well as K. Kalaitzakis, "Design of an optimal power radar for wind-energy-conversion applications," IEEE Trans. Ind. Electron., vol. 53, no. 2, pp. 486-- 494, Apr. 2006.

[7] B. Kou, Y. Bai as well as L. Li, "An unique wind power generator system with automated optimum power monitoring ability," IEEE Trans. Power Convers., vol. 28, no. 3, pp. 632-- 642, Sep, 2013.