

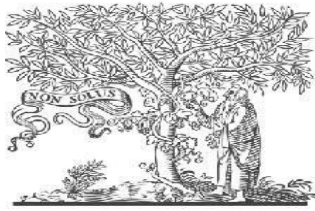

COPY RIGHT



ELSEVIER
SSRN

2023IJIEMR. Personal use of this material is permitted. Permission from IJIEMR must be obtained for all other uses, in any current or future media, including reprinting/republishing this material for advertising or promotional purposes, creating new collective works, for resale or redistribution to servers or lists, or reuse of any copyrighted component of this work in other works. No Reprint should be done to this paper, all copy right is authenticated to Paper Authors IJIEMR Transactions, online available on 28th April 2023.

Link : <https://ijiemr.org/downloads/Volume-12/Issue-04>

10.48047/IJIEMR/V12/ISSUE04/196

Title Anti Sleep Device

Pages: 1513-1519

Paper Authors

Dr. K.Satyanarayana, T.HariKrishnaReddy, Y.J.Mahindra, P.V.Shyamprasad, S.Vamsi



USE THIS BARCODE TO ACCESS YOUR ONLINE PAPER

To Secure Your Paper As Per **UGC Guidelines** We Are Providing A Electronic Bar Code

Anti Sleep Device

Dr. K.Satyanarayana (M.E,Ph.D)

Professor & Head, Department of MECHANICAL,
Vasireddy Venkatadri Institute of Technology, Nambur, Guntur Dt., Andhra Pradesh.

T.HariKrishnaReddy, Y.J.Mahindra, P.V.Shyamprasad, S.Vamsi

^{2,3,4,5} UG Students, Department of MECHANICAL,
Vasireddy Venkatadri Institute of Technology, Nambur, Guntur Dt., Andhra Pradesh.

¹ **E-Mail ID: tigireddyharikrishnareddy7773@gmail.com (T.Harikrishnareddy)**

Being engaged constantly in the modern world is quite difficult because of hectic schedules. Imagine that you are drained from the difficulties of the day as you drive home from work. He is driving with his hands on the wheel and foot on the brake when all of a sudden he begins to feel sleepy, his eyes start to close, his vision blurs, and before he realises it, he has passed out. In addition to accidents and possible fatalities, driving while fatigued can have serious consequences. It's imperative to discover a solution because this situation happens much more frequently than we realise. So, in order to solve this problem, we created a Driver Anti-sleep Device. making use of this technology With a sound in between This situation changes when the button is pushed. After 30 minutes, a fresh timer is set to begin when the reset switch is depressed, resulting in the same outcomes.

Keywords; Schmitt trigger, transistor, drowsy, and hectic.

Introduction

Long-distance and night-shift drivers can benefit from the effort because it alerts them when they start dozing off while driving. The project's design consists of an ultrasonic transmitter, receiver, and microcontroller. The transmitter constantly emits signals at a frequency of 40 KHz in the general direction of the gazing wheel, which are picked up by the ultrasonic receiver. The circuit determines its distance from the steering wheel by measuring the amount

of time required for ultrasonic pulses to be reflected and received.

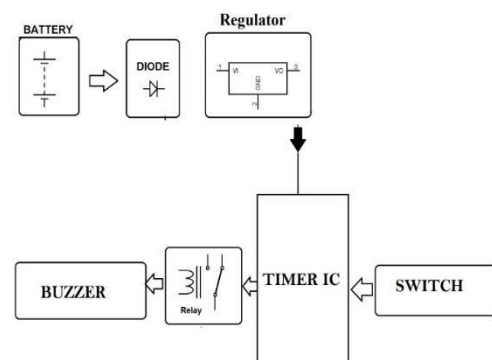

If a driver sleeps, their cranium will become heavy. When the antenna is

angled towards the steering column, it takes less time for the receiver to pick up the reflected signals.

Battery

A grouping of one or more electrochemical cells called an electrical battery is used to convert chemical energy that has been saved into electrical energy. Batteries are now a common power source for a variety of domestic and commercial purposes. Batteries can either be used once and then discarded, as in standby power applications, or they can be recharged frequently over time. Smaller cells are used to power gadgets like hearing aids and wristwatches, while larger batteries provide standby power for telephone lines or computer data centres.

Lead acid

The second part of the 19th century saw the invention of lead-acid batteries, which have proven to be tried, true, and dependable. They are made up of six different cells, each of which generates 2 volts, giving them a total value of 12 volts. When broken down into its simplest components, each cell is made up of a lead dioxide electrode, a "spongy" lead metal anode, and an electrolyte of sulfuric acid. (positive). The lead sulphate coating develops on both electrodes as the battery drains, and the majority of the sulfuric acid is converted into water. The external circuit receives electricity at the same moment that electrons leave the battery and travel there.

Chrome Nickel

Nickel-cadmium batteries (NiCd, pronounced "nicad") are commonly used

to replace disposable 1.5-volt batteries in items such as toys, flashlights, and power tools. Numerous instances of charging and discharging are possible, they cost not too much,

Lithium-ion

Your cellphone, MP3 player, and laptop most likely use lithium-ion batteries, which are the rechargeable battery variety that is growing the quickest. What are lithium's advantages? It is an excellent idea to use it to create batteries because it is a lightweight metal that creates ions easily.

Nickel-metal-hydride (NiMH)

Nickel metal hydride batteries, which function identically, have less of a problem with the alleged "memory effect." In the 1990s, they became well-liked as alternatives to NiCd batteries, in part because of environmental worries about cadmium. Utilized in appliances like cellphones, (which is more typical with something like power tools).

555 TIMER

The 555 timer chip is an incredibly robust and stable 8-pin component that can be used as a highly accurate Monostable, Bistable, or Astable Multivibrator to create a variety of applications, such as one-shot or delay timers, pulse generation, LED and lamp flashers, alarms and tone generation, logic clocks, frequency division, power supplies and

converters, etc. Essentially, any device that requires a timer of some kind.

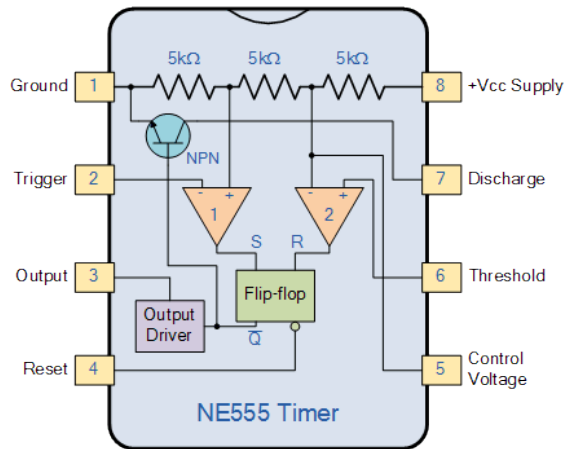

The monostable 555 timer

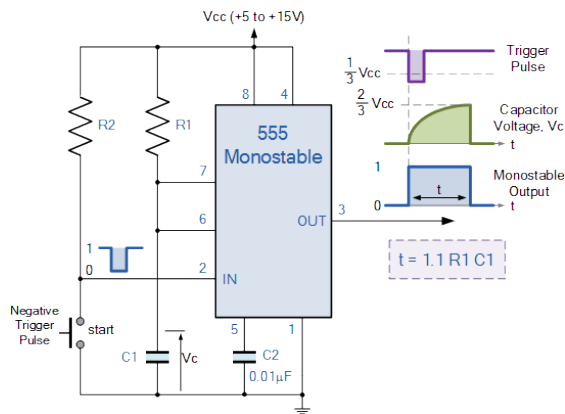

A negative-going pulse applied to pin 2 triggers the Monostable 555 Timer, and this trigger pulse must be much shorter than the output pulse width in order to allow the timing capacitor enough time to charge and then fully discharge. Up until the point at which it is turned off, the 555 Monostable will remain in this "HIGH" unstable output condition.

The predetermined time period for the $R_1 \times C_1$ network is over. We can determine how long the output voltage is "HIGH" or at a logic "1" level by solving the time constant equation shown below.

$$\tau = 1.1 R_1 C_1$$

R is measured in Ω , C is measured in farads, and t is measured in seconds.

555 timer illustrations

A Monostable 555 Timer is needed to introduce a time delay into a device. Identify thewe obtain the calculated value for the resistor, R , as:

$$R = \frac{t}{1.1C} = \frac{0.5}{1.1 \times 10\mu F} = \frac{0.5}{1.1 \times 10 \times 10^{-6}} = 45.5k\Omega$$

A switchable 555 timer

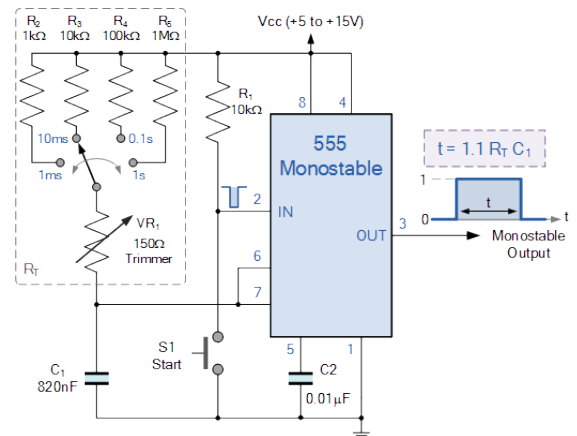

We can directly choose the values of R and C for each of the required components, just like we did in the example above. But because we must compute in either kilohms (K), megahms (M), microfarads (F), or picafarads (pF), it is very easy to obtain a time delay that is off by a factor of ten.

Monostable nomograph

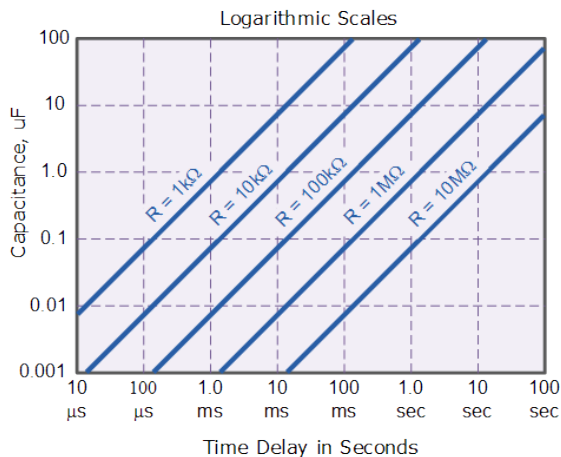

Consequently, by choosing appropriate values of C and R in the ranges of 0.001uF to 100uF and 1k to 10M's, respectively, we may read the expected output frequency directly from the nomograph graph and obviate any calculation mistake. In actual use, the timing resistor for a monostable 555 timer should have a value of either 1k or 20M.

Bistable 555 timer (fli_flop)

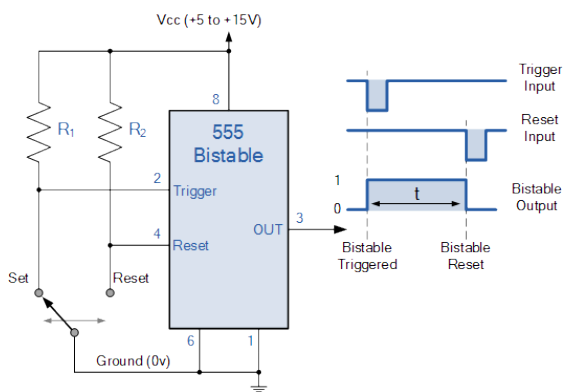

Controlling the trigger and reset inputs of the 555 timer, which are kept "HIGH" by the two pull-up resistors R1 and R2, allows the output waveform to be switched. When the trigger input (pin 2) is "LOW" and the switch is in the

"SET" position, the output state changes to "HIGH," and when the reset input (pin 4) is "LOW" and the switch is in the "RESET" position, the output state changes to "LOW"

555 timer output

This 555 timer explanation would not be complete without talking about the switching and drive capabilities of the 555 timer, or even the dual 556 timer IC.

Sinking and Sourcing the 555 Timer

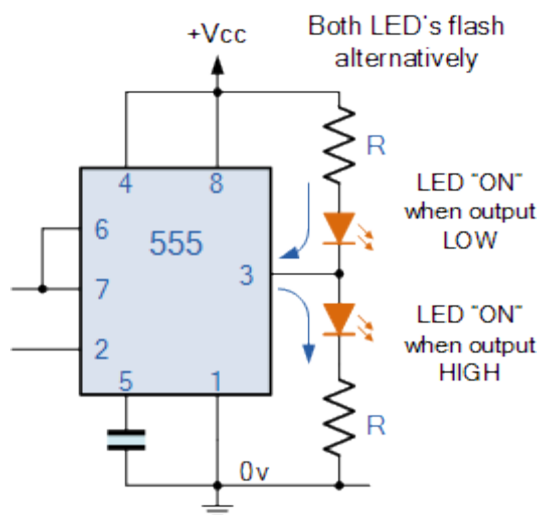
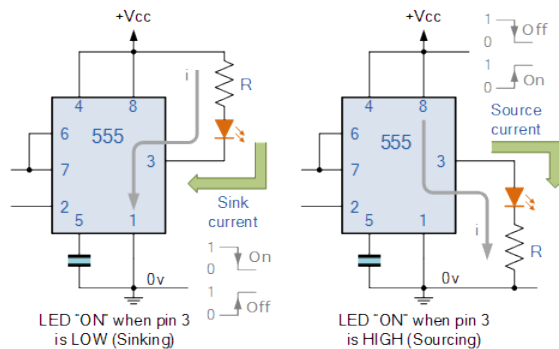

the output load current's drain and source Both LEDs can be attached to the output terminal at once thanks to the 555 timer's dual functionality, but only one of them will

turn on depending on whether the output state is "HIGH" or "LOW." This is demonstrated in the circuit on the left. Depending on the output, the two LEDs will

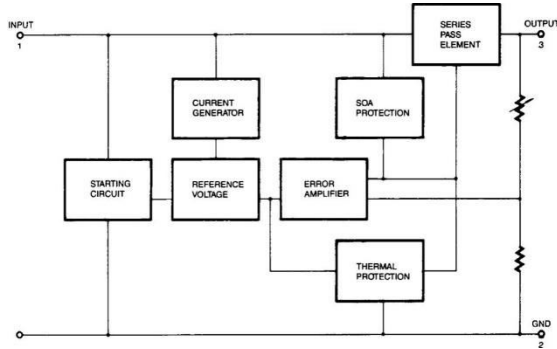

be switched alternately "ON" and "OFF." To keep the LED current below 20mA, a resistor, R, is used.

555 Timer Transistor Driver

If the load current is high, the transistor in the two cases above can be swapped out for a Power MOSFET or a Darlington transistor. If utilising ,It is desirable to connect a freewheeling (or flywheel) diode directly across the load terminals when using an inductive load, such as a motor, relay, or electromagnet, to absorb any back emf voltages produced by the inductive device when it changes state.

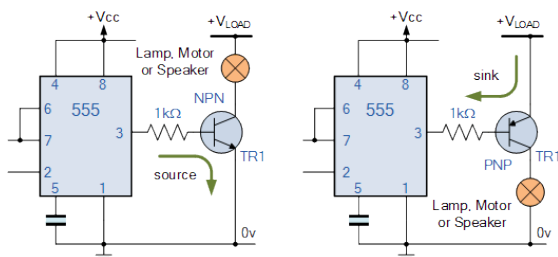

VOLTAGE REGULATOR 7805

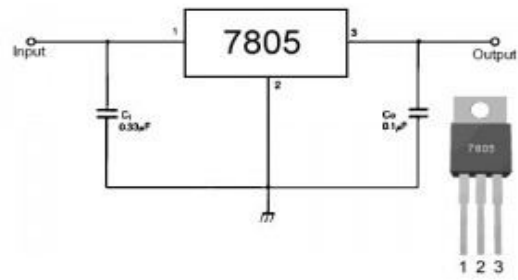

The TO-220/D-PAK package and a number of fixed output voltages make the three-terminal positive regulators of the LM78XX/LM78XXA family useful in a wide range of applications. Internal current limiting, thermal shutdown, and safe operating area protection are all used by each kind, making It's practically unbreakable. They are capable of producing over 1A of output current when sufficient heat sinking is offered.

Although designed primarily as fixed voltage regulators, these devices can be used with external components to obtain adjustable voltages and currents.

Internal Block Diagram

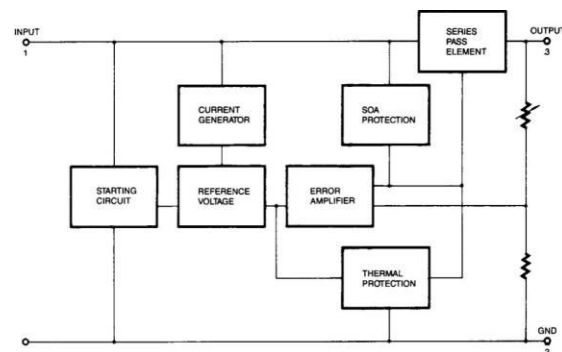

Absolute Maximum Ratings

Parameter	Symbol	Value	Unit
Input Voltage (for $V_O = 5V$ to $18V$)	V_I	35	V
(for $V_O = 24V$)	V_I	40	V
Thermal Resistance Junction-Cases (TO-220)	$R_{\theta JC}$	5	$^{\circ}C/W$
Thermal Resistance Junction-Air (TO-220)	$R_{\theta JA}$	65	$^{\circ}C/W$
Operating Temperature Range (KA78XX/A/R)	T_{OPR}	0 ~ +125	$^{\circ}C$
Storage Temperature Range	T_{STG}	-65 ~ +150	$^{\circ}C$

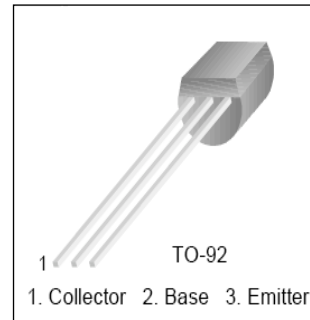

PUSH BUTTONS

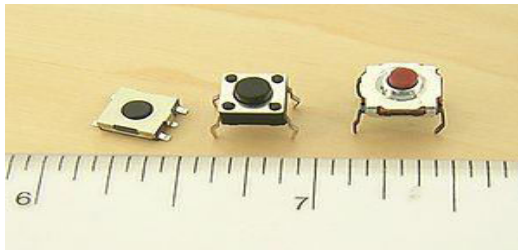

A push-button, also referred to as a pushbutton or simply a button, is a simple switch device used to regulate numerous functions of a machine or process. Buttons are made from hard materials, typically plastic or metal. It is usually simple to press or push because the surface is flat or shaped to suit a human finger or hand. Buttons are typically biased switches; however, because of their physical characteristics, even many un-biased buttons require a spring to revert to their un-pushed state. There are many words that describe "pushing" a button, such as press, depress, mash, and strike.

Push to on button:

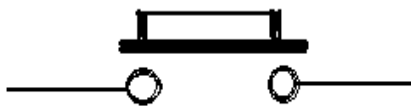

BC 547

We are aware that the transistor operates on "CURRENT" and that between the collector and emitter terminals, a significant current (I_c) flows freely through the transistor. The transistor's base can operate as a form of current control input, but only when a tiny biasing current (I_b) is flowing into the base terminal. The term "DC Current Gain" refers to the device's ratio of these two currents (I_c/I_b), which is represented by the symbol " h_{fe} " or, more recently, "Beta" (β). It is a ratio, hence beta has no units. Additionally, the transistor itself determines the current gain, or Alpha, (α), that flows from the emitter to the collector terminal, I_c/I_e . Given that the emitter current I_e equals

Conclusions

The initiative is helpful for night shift drivers and long distance drivers because it informs them when they doze off. An ultrasonic transmitter, receiver, and microcontroller are all included in the project's circuit. The ultrasonic receiver receives signals that the transmitter continuously sends at a frequency of 40 KHz in the direction of the gazing wheel. The circuit measures the amount of time

needed for ultrasonic waves to be reflected and received, and uses this information to calculate how far away the circuit is from the steering wheel.

The amount of time it takes for the receiver to pick up reflected signals is shortened if the driver is sleeping since his head will be angled towards the steering wheel. Consequently, the circuit learns that the driver has fallen asleep, and the microcontroller will promptly sound the buzzer to wake up the driver. The device can therefore prevent accidents and ensure the safety of the driver and passengers.

REFERENCES

- www.beyondlogic.org
- www.wikipedia.org
- www.howstuffworks.com
- www.alldatasheets.com