



COPY RIGHT



2019IJIEMR. Personal use of this material is permitted. Permission from IJIEMR must be obtained for all other uses, in any current or future media, including reprinting/republishing this material for advertising or promotional purposes, creating new collective works, for resale or redistribution to servers or lists, or reuse of any copyrighted component of this work in other works. No Reprint should be done to this paper, all copy right is authenticated to Paper Authors

IJIEMR Transactions, online available on 27th Jul 2019. Link

[:http://www.ijiemr.org/downloads.php?vol=Volume-08&issue=ISSUE-07](http://www.ijiemr.org/downloads.php?vol=Volume-08&issue=ISSUE-07)

Title **DESIGN AND STEADY STATE THERMAL ANALYSIS OF IC ENGINE CYLINDER BY FEM ON VARIOUS MATERIAL SELECTIONS**

Volume 08, Issue 07, Pages: 427–439.

Paper Authors

A. SAKTHIVEL, B. KEERTHI

VISAKHA TECHNICAL CAMPUS, NARAVA, Visakhapatnam, andhrapradesh



USE THIS BARCODE TO ACCESS YOUR ONLINE PAPER

To Secure Your Paper As Per **UGC Guidelines** We Are Providing A Electronic Bar Code

DESIGN AND STEADY STATE THERMAL ANALYSIS OF IC ENGINE CYLINDER BY FEM ON VARIOUS MATERIAL SELECTIONS.

¹A. SAKTHIVEL, ²B. KEERTHI

¹STUDENT, DEPT. OF MECHANICAL ENGINEERING, VISAKHA TECHNICAL CAMPUS, NARAVA, VISAKHAPATNAM, ANDHRAPRADESH

²ASSISTANT PROFESSOR, DEPT. OF MECHANICAL ENGINEERING VISAKHA TECHNICAL CAMPUS, NARAVA, VISAKHAPATNAM, ANDHRAPRADESH

¹ayyakannusakthivel@gmail.com, ²keerthipatnaik@gmail.com

ABSTRACT

The combustion chamber of an IC engine is subjected to high temperature variations and thermal stresses, on which fins are mounted in order to cool the cylinder and to increase the heat dissipation rate. In this report thermal analysis of engine block with fins were analyzed. By doing thermal analysis on cylinder block fins, it is helpful to know the temperature distribution and heat dissipation inside the cylinder. The principle behind the cooling of the cylinder block is to provide the fins over the cylinder block by which the heat transfer rate will be increased. In India, generally in two wheelers air cooled engines are used. For this purpose, extended surfaces i.e. fins are used, which are mounted on cylinder block and cylinder head. Though the efficiency of cooling in air cooled system is less as compared to the water cooled system still it is used because of less space available to keep accessories. In this project the extended surfaces i.e. fins of Honda Shine & Bajaj Discover two wheeler automobiles are tested to investigate effect on heat transfer rate by Cross-section, Fin Pitch, Fin Material and Fin Thickness. The parametric model of engine block fins has been developed in 3D by using Catia software and thermal analysis is done on with holes and without holes fins in order to determine heat flux and temperature distribution. Currently the material used for manufacturing cylinder fin body is Aluminum 2014 and Grey cast iron. Now proposed material is Aluminum 6061 in addition to this thesis. The thermal analysis has been done using all three materials by changing their applied geometries. Finally it was concluded that Aluminum alloy 6061 has the maximum heat dissipation rate of the cylinder fin body.

Keywords: Engine cylinder fins, Geometry, Material, Thermal Analysis.

CHAPTER 2 INTRODUCTION

1.1 INTRODUCTION

In case of Internal Combustion engines, combustion of air and fuel takes place inside the engine cylinder and hot gases are generated. The temperature of gases will be

around 800 to 1500°C. This is a very high temperature and may result into burning of oil film between the moving parts and may result into seizing or welding of the same. So, this temperature must be reduced to

about 150-200°C at which the engine will work most efficiently. Too much cooling is also not desirable since it reduces the thermal efficiency. So, the object of cooling system is to keep the engine running at its most efficient operating temperature. It is to be noted that the engine is quite inefficient when it is cold and hence the cooling system is designed in such a way that it prevents cooling when the engine is warming up and till it attains to maximum efficient operating temperature, then it starts cooling. It is also to be noted that: 20-25% of total heat generated is used for producing brake power (useful work).• Cooling system is designed to remove 30-35% of total heat.• Remaining heat is carried away by exhaust gases. The aim of this project is to find out the effect of fin geometry and fin pitch on cooling of the engine. As the fossil fuel reserves are depleting day by day, the spiraling fuel price is pushing the technology towards its limit to provide engines which are highly efficient and produce high specific power. Air cooled engines are gradually phased out and are being replaced by water cooled engines which are far more efficient in dissipating heat, but in cases of two wheelers and certain other applications, air cooled engines are the only viable option due to space constraints. The heat which is generated during combustion in an internal combustion engine should be maintained at the highest level possible to increase its thermal efficiency, but in order to prevent the thermal damage to the engine components and the lubricants some amount of heat must be removed from the system.

1.2 BASIC PRINCIPLES:

Various methods are used to cool Engine either by using gaseous fluid flow (air) or by a liquid coolant run through a heat exchanger (radiator) to cool the heat engine. We cannot

use water as a coolant due to the presence of sedimentation in water which results in the clogging of coolant passage and chemicals, such as salt, that chemically damage the engine. Thus, engine coolant flows through a heat exchanger i.e. radiator in a vehicle that is cooled by the body of water.

Various methods used for cooling of automobile engines are:

- Air Cooling
- Water cooling

1.2.1 AIR-COOLING

Cars and trucks using direct air cooling (without an intermediate liquid) were built over a long period beginning with the advent of mass produced passenger cars and ending with a small and generally unrecognized technical change.

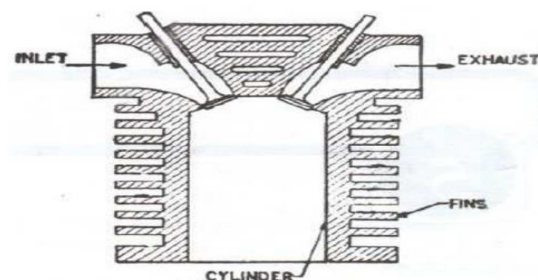

Figure 1 Air-cooling

In normal cases, larger parts of an engine remain exposed to the atmospheric air. When the vehicles run, the air at a certain relative velocity impinges upon the engine, and sweeps away its heat. The heat carried away by the air is due to natural convection, therefore this method is known as natural air-cooling. Engines mounted on 2-wheelers are mostly cooled by natural air. As the heat dissipation is a function of frontal cross-sectional area of the engine, therefore there exists a need to enlarge this area. An engine with a larger area will become bulky and in turn will also reduce the power by weight ratio. Hence, as an alternative arrangement, fins are constructed to enhance the frontal

cross-sectional area of the engine. Fins (or ribs) are sharp projections provided on the surfaces of cylinder block and cylinder head. They increase the outer contact area between a cylinder and the air. Fins are, generally, casted integrally with the cylinder. They may also be mounted on the cylinder.

ADVANTAGES OF AIR COOLED SYSTEM:

Following are the advantages of air cooled system:

- Radiator/pump is absent hence the system is light.
- In case of water cooling system there are leakages, but in this case there are no leakages.
- Coolant and antifreeze solutions are not required.
- This system can be used in cold climates, where if water is used it may freeze.

DISADVANTAGES OF AIR COOLED SYSTEM:

- Comparatively it is less efficient.
- It is used in aero planes and motorcycle engines where the engines are exposed to air directly.

1.2.2 LIQUID COOLING

Liquid cooling is also employed in maritime vehicles. For vessels, the seawater itself is mostly used for cooling. In some cases, chemical coolants are also employed (in closed systems) or they are mixed with seawater cooling. Fins have always been used as a passive method of enhancing the convection heat transfer from cylinders. The presence of the solid fins has an effect on both the aerodynamic as well as the thermal characteristics of the flow. The fins tend to obstruct the air flow near the cylinder surface, thus reducing the heat transfer from the cylinder to the surrounding fluid. On the other hand, the fins increase the heat transfer

area resulting in an increase in the heat transfer from the cylinder to the surrounding fluid. The net result of these two opposing effects depends on the combination of the number of fins, fin height, and Reynolds number. A.R.A. Khaled [14], modeled and analyzed analytically heat transfer through joint fins systems that are exposed to two different convective media from its both ends and concluded that heat transfer through joint fins is maximized at certain critical length of each portion. Bassam A/K Abu-Hijleh [15-16] investigated numerically the problem of laminar natural and forced convection from a horizontal cylinder with multiple

1.3 FINS:

A fin is a surface that extends from an object to increase the rate of heat transfer to or from the environment by increasing convection. The amount of conduction, convection, radiation of an object determines the amount of heat it transfers. Increasing the temperature difference between the object and the environment, increasing the convection heat transfer coefficient, or increasing the surface area of the object increases the heat transfer. Sometimes it is not economical or it is not feasible to change the first two options. Adding a fin to the object, however, increases the surface area and can sometimes be an economical solution to heat transfer problems. Circumferential fins around the cylinder of a motor cycle engine and fins attached to condenser tubes of a refrigerator are a few familiar examples.



Figure 2 Automobile fin

Why Engine Cooling is required:

- 1) Engine valves wrap due to low heat transfer.
- 2) Changes the material properties for critical components like Piston, Engine cylinder, etc...
- 3) Thermal stresses will be induced into the engine critical parts which cause distortion and cracks in the parts.
- 4) Pre Ignition occurs due to overheating of Spark plug .
- 5) Overheating reduces the efficiency .

Application of Fins:

- Electrical components
- Cooling of motor cycles
- Compressors
- Electric Motors
- Refrigerators
- Radiators

CHAPTER 3 LITERATURE SURVEY

Gokul Karthik [10] composed a sunken rectangular blade body utilized as a part of a Honda Unicorn Motorcycle and display in parametric 3D demonstrating programming Pro/Engineer. Present utilized material for balance body is Aluminum 2024 composite. The state of the balance is rectangular; they have changed the shape with rectangular curved molded. The default thickness of blade is 3mm; they are diminishing it to 2.5mm. By decreasing the thickness furthermore by changing the state of the balance to bend formed, the heaviness of the blade body lessens along these lines expanding the proficiency. The heaviness of the blade body is additionally lessened. They have done warm examination on the balance body by changing geometry and thickness. By watching the investigation results, utilizing Rectangular sunken balance, material Aluminum composite 6061 and thickness of 2.5mm is better since

warmth exchange rate is more. Be that as it may, by utilizing rectangular curved balances the heaviness of the blade body is likewise diminished. So on the off chance that we consider weight, utilizing bended blades is superior to anything different geometries. So we can presume that utilizing material Aluminum 2024 combination is better, diminishing thickness to 2.5mm is better and utilizing balance shape rectangular inward by investigation and blade shape bended by weight is better. By watching the outcomes, utilizing curved blades the warmth lost is more, productivity and adequacy is additionally more.

N. Phani Raja Rao et al. analyzed the thermal properties by varying geometry with and without holes, material and thickness of cylinder fins. Different material used for cylinder fin were Aluminium Alloy 2024, Aluminium alloy 6061 and Magnesium alloy which have higher thermal conductivities and shown that by reducing the thickness and also by changing the shape of the fin to circular shaped, the weight of the fin body reduces thereby increasing the heat transfer rate and efficiency of the fin. The results shows, by using circular fin with material Aluminium Alloy 6061 is better since heat transfer rate, Efficiency and Effectiveness of the fin is more.

Pulkit Agarwal etc. [1] simulated the heat transfer in motor cycle engine fan using CFD analysis. It is observed that ambient temperature reduces to the very low value; it results in over cooling and poor efficiency of the engine. They have concluded that over cooling also affects the engine efficiency because over cooling excess fuel consumption occurs.

Masao Yosidha etc. [2] investigated effect of number of fins, fin pitch and wind velocity on air cooling using experimental

tunnel. Heat releases from cylinder did not improved when the cylinder have the more fins and too narrow a fin pitch at lower wind velocities because it is difficult for the air to flow into the narrower space between the fins, the temperature between them increased..

Fernando Illan simulated the heat transfer from cylinder to air of a two-stroke internal combustion finned engine. The cylinder body, cylinder head (both provided with fins), and piston have been numerically analyzed and optimized in order to minimize engine dimensions. The maximum temperature admissible at the hottest point of the engine has been adopted as the limiting condition. Starting from a zero-dimensional combustion model developed in previous works, the cooling system geometry of a two-stroke air cooled internal combustion engine has been optimized in this paper by reducing the total volume occupied by the engine. A total reduction of 20.15% has been achieved by reducing the total engine diameter D from 90.62 mm to 75.22 mm and by increasing the total height H from 125.72 mm to 146.47 mm aspect ratio varies from 1.39 to 1.95. In parallel with the total volume reduction, a slight increase in engine efficiency has been achieved. G. Babu and M. Lavakumar analyzed the thermal properties by varying geometry, material and thickness of cylinder fins. The models were created by varying the geometry, rectangular, circular and curved shaped fins and also by varying thickness of the fins. Material used for manufacturing cylinder fin body was Aluminium Alloy 204 which has thermal conductivity of 110-150W/mk and also using Aluminium alloy 6061 and Magnesium alloy which have higher thermal conductivities. They concluded that by

reducing the thickness and also by changing the shape of the fin to curve shaped, the weight of the fin body reduces thereby increasing the efficiency. The weight of the fin body is reduced when Magnesium alloy is used and using circular fin, material Aluminium alloy 6061 and thickness of 2.5mm is better since heat transfer rate is more and using circular fins the heat lost is more, efficiency and effectiveness is also more.

J. Ajay Paul et.al. carried out Numerical Simulations to determine heat transfer characteristics of different fin parameters namely, number of fins, fin thickness at varying air velocities. A cylinder with a single fin mounted on it was tested experimentally. The numerical simulation of the same setup was done using CFD. Cylinders with fins of 4 mm and 6 mm thickness were simulated for 1, 3, 4 & 6 fin configurations. They concluded that 1. When fin thickness was increased, the reduced gap between the fins resulted in swirls being created which helped in increasing the heat transfer. 2. Large number of fins with less thickness can be preferred in high speed vehicles than thick fins with less numbers as it helps inducing greater turbulence and hence high

CHAPTER 4 PROJECT OVERVIEW

3.1 PROBLEM DEFINITION:

In the present Project investigation on thermal issues on automobile fins were carried out. Investigation yields the temperature behaviour and heat flux of the fins due to high temperature in the combustion chamber. Ansys work bench is utilized for analysis. The analysis is done for different models of fins that are commercially available now a days and a comparison is thus established between

them. Also the material and design changed (with holes and without holes) so that better heat transfer rate can be obtained.

3.2 OBJECTIVES OF THE PROJECT:

The following are the main objectives of the present work:

- 1) To design cylinder with fins for a 125cc engine by same geometry such as with holes and without holes concept.
- 2) To determine steady state thermal properties of the proposed fin models.
- 3) To identify suitable alloy for the fabrication based on results obtained from finite element analysis and analytical method.

3.3 METHODOLOGY

Step 1: Collecting information and data related to cooling fins of IC engines.

Step 2: A fully parametric model of the Engine block with fin is created in catia software.

Step 3: Model obtained in igs is analyzed using ANSYS 14.5, to obtain the heat rate, temperature distribution

Step 4: Manual calculations theoretically and analytically are done.

Step 5: Finally, we compare the results obtained from ANSYS and compared different geometry and materials.

3.4 EXPERIMENTAL SETUP:

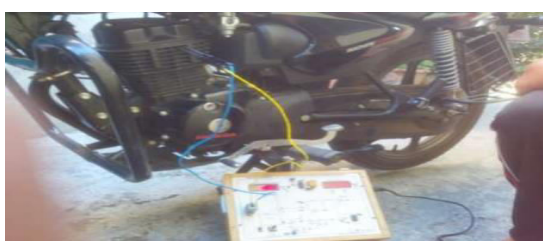

Figure 3 Experiment set up

Experimental setup is shown in figure 5.1 the setup simply consist of thermocouple rod placed on surface of fin of which temperature readings are to be taken. Thermocouple rod is attached to thermocouple temperature trainer kit which consist of digital display which will provide us actual readings directly. The k-type thermocouple is used in experiment. The readings are taken on stationary engine after reaching to steady state condition. Following observations are found.

TABLE 1 Observation for temperature reading of honda shine

Model name	Honda Shine
CC	125
Stroke(mm)	58
Bore(mm)	52
No. of fins	6
Fin pitch(mm)	10
Fin thickness(mm)	2.5
Fin material	Al alloy
Position of Fins w.r.t. cylinder axis	Perpendicular

TABLE 2 Temperature readings

S.NO	FIN No	Temperature(c°)
1	1	129
2	2	126
3	3	121
4	4	120
5	5	119
6	6	115

Note: The time to reach steady state was 90 minutes there after the readings were taken.

Calculations for Peak Temperature Produced in Cylinder of Honda Shine

(Data taken from technical specification of automotive vehicle)

Initial temperature during suction, $T_1 = 30^\circ\text{C}$

Initial pressure $P_1 = 1 \text{ bar}$

Compression ratio, $rc = 9.5$

Peak pressure produced, $P_3 = 35 \text{ bar}$

$P_2 = P_1 \times rc^\gamma$

$= 1 \times (9.5)^{1.4}$

$= 23.378 \text{ bar}$

$$T_2 = T_1 \times (rc)^{Y-1}$$

$$= 303 \times (9.5)^{1.4-1}$$

$$= 745.64 \text{ }^\circ\text{K}$$

$$T_3 = P_3 P_2 \times T_2 = 35 \times 23.378 \times 745.64$$

$$= 1116.32 \text{ K}$$

$$= 843.32 \text{ }^\circ\text{C}$$

Calculation for Heat Dissipated From Surface of Fins of Honda Shine

Assumptions made to calculate the heat dissipated or heat flux:-

- 1) Steady state one dimensional heat conduction.
- 2) Finite long fin and with negligible heat loss from fin tip.
- 3) Constant properties. Considering, h = Heat transfer coefficient

A_c = Cross section area of fin

K = Thermal conductivity

L = Length of fin.

w = Width of fin

t = Thickness of fin

P = Perimeter of fin

T_0 = Fin temperature

T_∞ = Ambient temperature of air.

For fin no 1

$$A_c = L \times t = (132 \times 10^{-3}) \times (2.5 \times 10^{-3})$$

$$= 0.132 \times 0.0025$$

$$= 0.00033 = 330 \times 10^{-6}$$

$$P = 132 \times 10^{-3} \text{ m}$$

$$ML = \sqrt{\frac{h \times p}{K \times A_c}} \times w$$

$$= \sqrt{\frac{30 \times 132 \times 10^{-3}}{240 \times 330 \times 10^{-6}}} \times 0.024$$

$$= \sqrt{\frac{3.96}{0.0792}}$$

$$= \sqrt{50} \times 0.024 = 0.1697$$

$$Q_1 = \sqrt{h \times P \times K \times A_c} \times (T_0 - T_\infty) \times \tanh(mL)$$

$$= \sqrt{30 \times 0.132 \times 240 \times 0.00033} \times (129 - 30) \times \tanh(0.169)$$

$$= \sqrt{0.313632}$$

$$= 0.560 \times 99 \times \tanh(0.169)$$

$$= 0.560 \times 99 \times 0.1674$$

$$Q_1 = 9.280 \text{ W}$$

Similarly for other fins heat dissipated can be calculated

$$Q_2 = 8.3083 \text{ W}$$

$$Q_3 = 7.237 \text{ W}$$

$$Q_4 = 6.5198 \text{ W}$$

$$Q_5 = 6.0048 \text{ W}$$

$$Q_6 = 5.4331 \text{ W}$$

Total heat transfer from fins, $Q_{\text{Honda Shine}} = 42.783 \text{ W}$

Heat flux calculation:-

Calculation from fin no 1

$$q_1 = \frac{\text{heat dissipated by fin}}{\text{area of cross section for fin}}$$

$$= \frac{Q_1}{A_c}$$

$$= \frac{31.29}{0.00033}$$

$$= 28121.21 \text{ W/m}^2$$

Similarly, heat flux can be calculated for other fins.

$$q_2 = 25176.66 \text{ W/m}^2$$

$$q_3 = 21930.30 \text{ W/m}^2$$

$$q_4 = 19756.96 \text{ W/m}^2$$

$$q_5 = 18196.36 \text{ W/m}^2$$

$$q_6 = 16463.93 \text{ W/m}^2$$

3.5 Designing to develop the work :

The 3-d model of cylinder head fin of rectangle shape is drawn in catia v5 interface using tools, is shown in fig. The circle in sketcher 52mm fin thickness is taken as 2.5mm, and remaining all dimensions are taken as per standard conditions, stroke length is 58 no. of fins is 6 fin pitch is 10 fig shows cylinder head fin of rectangular shape is drawn in catia v5 interface using tools by this is a just modified design with holes hole diameter is 3 mm of above sketch by changing geometry only.

3.6 MATERIAL PROPERTIES:

3.6.1 Mechanical Properties of Materials

1. GRAY CAST IRON:

S.NO	MATERIAL PROPERTIES	UNIT	VALUES
1	Density	Kg/m ³	7200
2	Young's modulus	GPa	110
3	Poisson's ratio		0.28
4	Bulk modulus	Pa	8.33×10 ¹⁰
5	Shear modulus	Pa	4.2969×10 ¹⁰
6	Tensile ultimate strength	Pa	2.4×10 ⁸
7	Compressive ultimate strength	Pa	8.2×10 ⁸
8	Thermal conductivity	W/m-k	52
9	Specific heat	J/kg-°C	447
10	Coefficient of thermal expansion	1/k	11×10 ⁻⁶

2. AL6061 ALLOY:

properties	Ultimate tensile strength	% Elong	Hardness in BHN
Specified	27kg/mm ²	8%	80

Materials	Thermal Conductivity (W/mk)	Heat transfer coefficient (W/m ² k)	Density (g/cc)	Melting Point (K)
Aluminium 6061	167	25	2.7	855

3.AL 2014 MATERIAL:

S.NO	MATERIAL PROPERTIES	UNIT	AL2014
1	Density	g/c c	2.80
2	Young's modulus	GPa	73
3	Poisson's ratio		0.33
4	Shear modulus	MPa	28
5	Tensile ultimate strength	MPa	480
6	Thermal conductivity	W/m-k	154
7	Specific heat	J/g-°C	0.88

4.CHAPTERINTRODUCTION TO CATIA

Welcome to CATIA (Computer Aided Three Dimensional Interactive Application). As anew user of this software package, you will join hands with thousands of users of this high-end CAD/CAM/CAE

tool worldwide. If you are already familiar with the previous releases, you can upgrade your designing skills with the tremendous improvement in this latest release.

4.1DESIGN PROCEDURE IN CATIA:

We created existing component original dimensions. The specification of first model engines cylinder block HONDA SHINE 125cc with dimensions of 132 x132x58 was made in 3D modeling software catia. There are Total number of fins were 8 , with number of gaps between the fins are 10,the thickness of fin are 2.5 mm, where the gap between the fins are 6 mm , in this model length of stroke is 58 mm. First go to sketcher workbench create the sketch 132x132x58 and now go to the existing workbench in part design apply pad option now it is converted into solid after go to sketcher workbench now create the rectangular fins now again go to the existing workbench apply groove option . finally appears like that as shown in the figure.

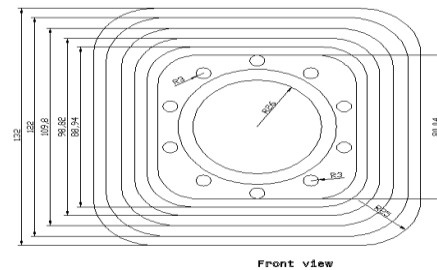

Figure 4Geometry dimensions with holes

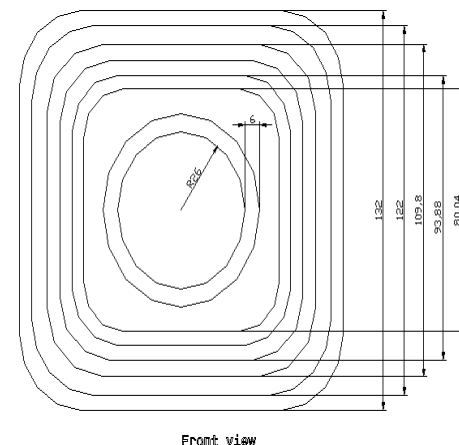

Figure 5 Without holes

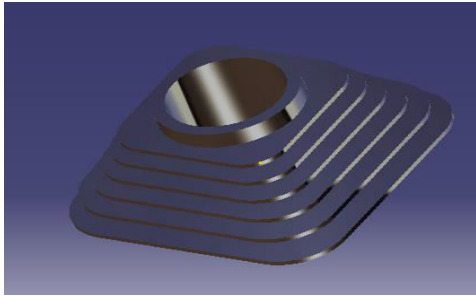

Figure 6 Modeling without holes

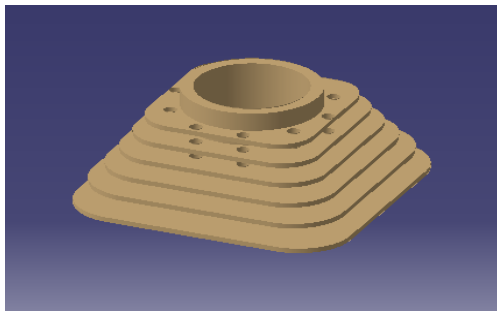

Figure 7 Modeling with holes

CHAPTER 5 INTRODUCTION TO ANSYS

ANSYS is a large-scale multipurpose finite element program developed and maintained by ANSYS Inc. to analyze a wide spectrum of problems encountered in engineering mechanics.

5.1 PROGRAM ORGANIZATION:

The ANSYS program is organized into two basic levels:

- Begin level
- Processor (or Routine) level

The Begin level acts as a gateway into and out of the ANSYS program. It is also used for certain global program controls such as changing the job name, clearing (zeroing out) the database, and copying binary files. When you first enter the program, you are at the Begin level.

At the Processor level, several processors are available. Each processor is a set of functions that perform a specific analysis task. For example, the general pre-processor (PREP7) is where you build the model, the solution processor (SOLUTION) is where you apply loads and obtain the solution, and

the general postprocessor (POST1) is where you evaluate the results of a solution. An additional postprocessor, POST26, enables you to evaluate solution results at specific points in the model as a function of time.

5.2 ANALYSIS PROCEDURE IN ANSYS:

Designed component in catia workbench after imported into Ansys workbench now select the steady state thermal analysis .

- 1.ENGINEERING MATERIALS (MATERIAL PROPERTIES).
- 2.CREATE OR IMPORT GEOMETRY.
- 3.MODEL(APPLY MESHING).
- 4.SET UP(BOUNDARY CONDITIONS)
- 5.SOLUTION
- 6.RESULTS

5.3 STEADY STATE THERMAL ANALYSIS:

A steady state thermal analysis calculates the effect of steady thermal load on a system or component, analyst were also doing the steady state analysis before performing the transient analysis. A steady state analysis can be the last step of transient thermal analysis. We can use steady state thermal analysis to determine temperature, thermal gradient, heat flow rates and heat flux in an object that do not vary with time.

A steady state thermal analysis may be either linear with constant material properties or non linear with material properties that depend on temperature. The thermal properties of most material do vary with temperature, so the analysis is usually non linear.

5.4 MESHING :

Mesh for with holes and without holes

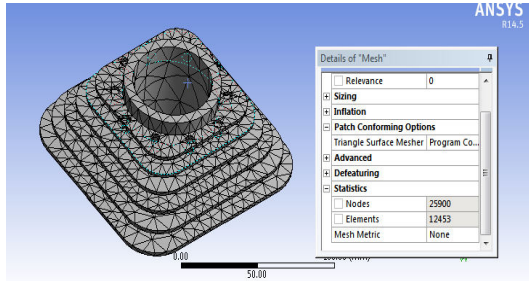

Figure 8 Mesh with holes

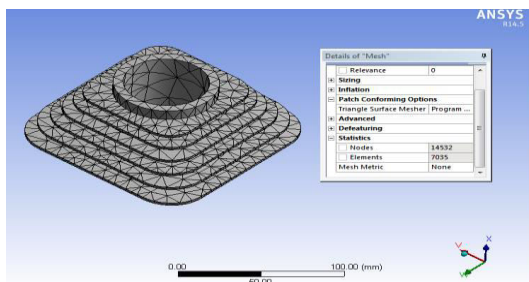

Figure 9 Mesh without holes

5.5 BOUNDARY CONDITIONS:

The following are the input parameters:

S.No	LOADS	UNITS	VALUE
1	INSIDE TEMPERATURE	°c	843.32
2	FILM COEFFICIENT	W/m ² K	25
3	AMBIENT TEMPERATURE	K	303
4	MATERIALS		AL6061,AL2014,GREYCASTIRON

Table 8 Input parameters

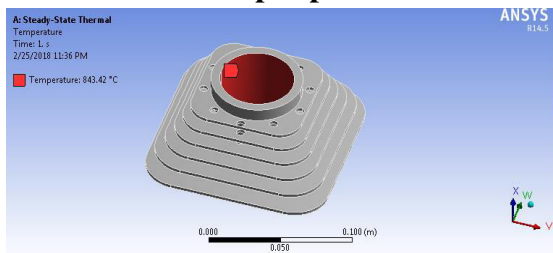

Figure 10 Temperature of boundary conditions with holes

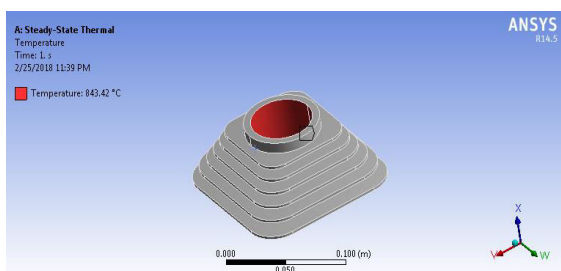

Figure 11 Temperature of boundary conditions and without holes

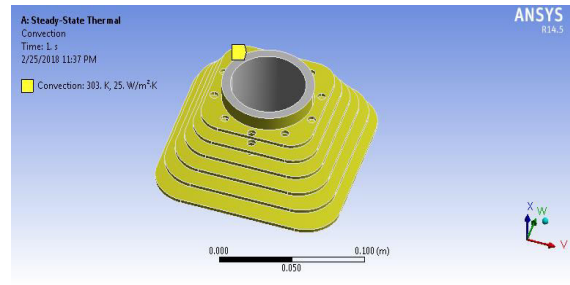

Figure 12 Convection of boundary conditions with holes

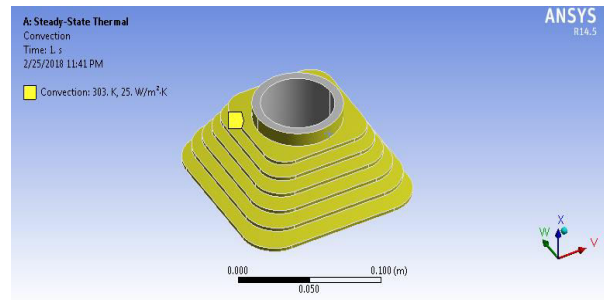

Figure 13 Convection of boundary conditions with out holes

CHAPTER 6 RESULTS AND DISCUSSION

6.1 TEMPERATURE DISTRIBUTION OF EXISTING MODEL

6.1.1 WITH HOLES CYLINDER FINNS:

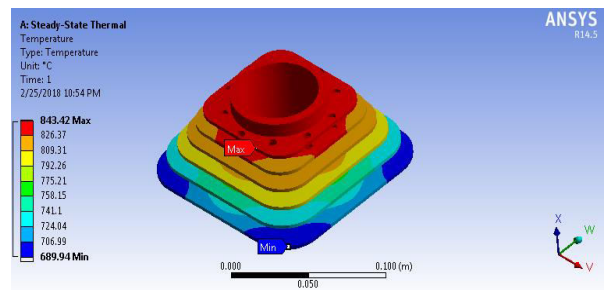

Figure 14 Temperature distribution on al2014

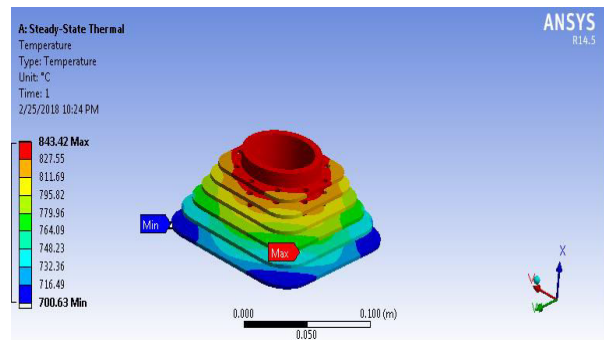

Figure 15 Temperature distribution on Al6061

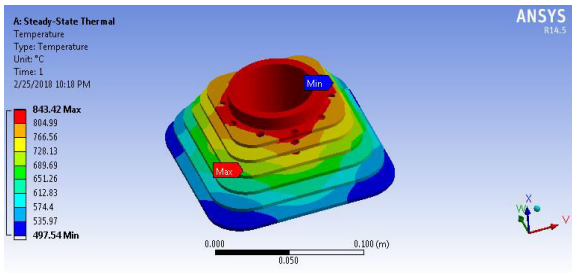

Figure 16 Temperature distribution on grey cast iron

6.1. 2 WITHHOLES CYLINDER FINS: Temperature distribution of existing models

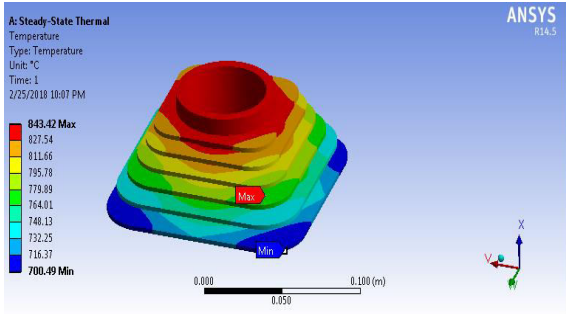

Figure 17 Temperature distribution on al2014

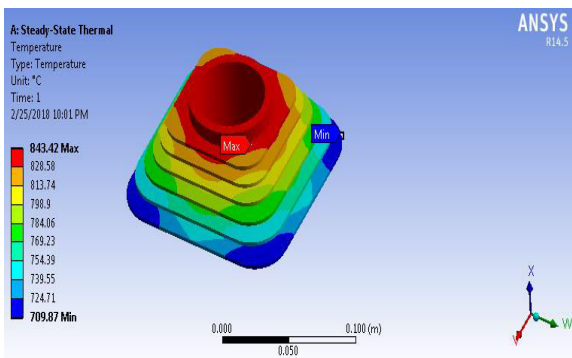

Figure 18 Temperature distribution on al6061

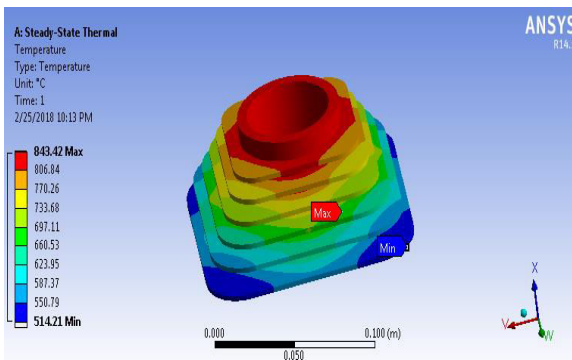

Figure 19 Temperature distribution on grey cast iron

6.2 Total heat flux of existing models:

6.2.1 WITH HOLES CYLINDER FINS:

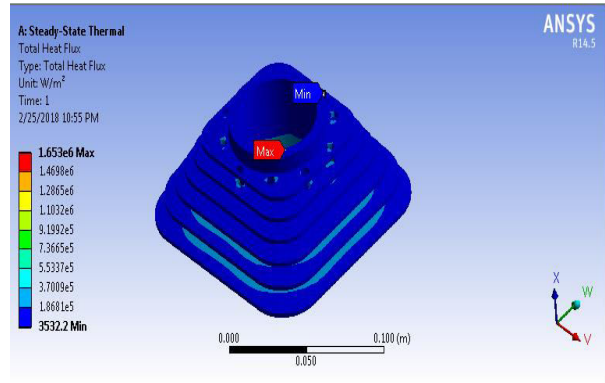

Figure 20 Heat flux on al2014.

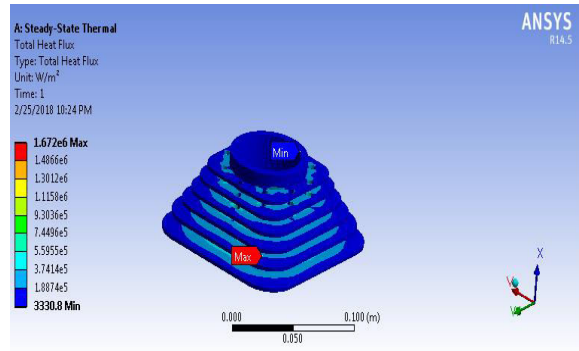

Figure 21 Heat flux on al6061

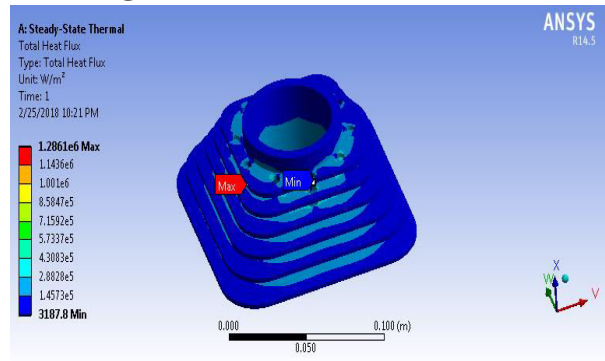

Figure 22 Heat flux on grey cast iron

6.2.2 WITHOUT HOLES CYLINDER FINS:

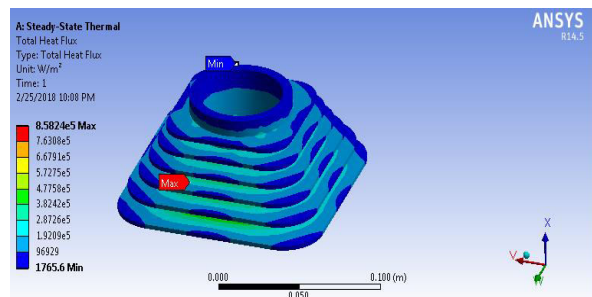

Figure 23 Heat flux on al2014

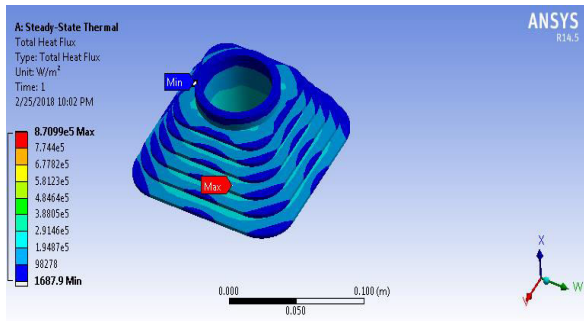

Figure 24 Heat flux in al6061

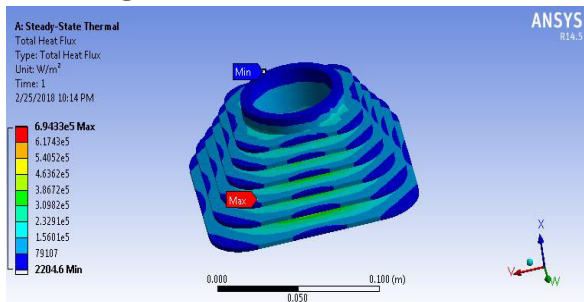

FIGURE 25 HEAT FLUX IN GREY CAST IRON

6.3 GRAPHS BETWEEN WITH HOLES AND WITHOUT HOLES TEMPERATURE DISTRIBUTION CYLINDER FINS:

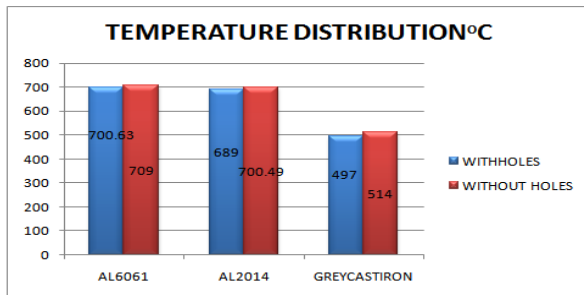

FIGURE 26 WITH HOLES AND WITHOUT HOLES TEMPERATURE DISTRIBUTION OF CYLINDER FINS

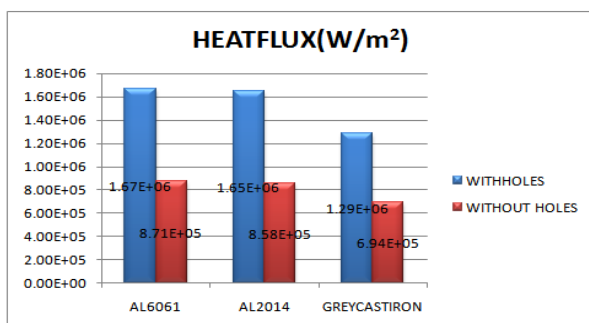

FIGURE 27 TOTAL HEATFLUX WITH AND WITHOUT HOLES

CHAPTER 7 CONCLUSION

Cylinder fins plays an important role in heat transfer ,Design and analysis done with different geometry and with different materials Design of cylinder block. The fins geometry and cross sectional area affects the heat transfer coefficient In this present work, cylinder block created in 3D software CATIA two different designs with and without holes taking specifications Honda shine 125cc in which perpendicular fins are mounted. After that modifications is done in engine cylinder block fins, with and without holes. There is a scope of improvement in heat transfer of air-cooled engine cylinder fin,. finally concluded the suitable design and material for the cylinder fins on these materials grey cast iron,Al2014,Al6061 materials, finally concluded the al6061 is suitable for cylinder fins because of better heat flux rate .

REFERENCES

- [1] A. H Gibson, “The Air Cooling of Petrol Engines”, Proceedings of the Institute of Automobile Engineers, Vol.XIV(1920)
- [2] A. E Biermann and B. Pinkel, “Heat Transfer from Finned Metal Cylinders in an Air Stream”, NACA ReportNo.488 (1935).
- [3] Gardner, K. A., “Efficiency of Extended Surfaces,” ASME, J. Heat Transfer, 67, 621-631, (1945).
- [4] Prof. R.B.Gupta, “Automobile engineering,” SatyaPrakashan, Incorporating, Tech India Publications, (1998).
- [5] D.ThornhillD, A.Graham, G.Cunningham, P.TroxierandR.Meyer, “Experimental Investigation into the Free Air-Cooling of Air-Cooled Cylinders”, SAE Paper 2003-32-0034, (2003).



[6] Dr. Kirpal Singh, 2004, Automobile engineering vol.II, Standard Publishers Distributors, Delhi, (2004).

[7] Zakhirhusen, Memon K., Sundararajan T., Lakshminarasimhan V., Babu Y.R. and HarneVinay,