

COPY RIGHT



ELSEVIER
SSRN

2019IJIEMR. Personal use of this material is permitted. Permission from IJIEMR must be obtained for all other uses, in any current or future media, including reprinting/republishing this material for advertising or promotional purposes, creating new collective works, for resale or redistribution to servers or lists, or reuse of any copyrighted component of this work in other works. No Reprint should be done to this paper, all copy right is authenticated to Paper Authors

IJIEMR Transactions, online available on 1st Jun 2019. Link

[:http://www.ijiemr.org/downloads.php?vol=Volume-08&issue=ISSUE-06](http://www.ijiemr.org/downloads.php?vol=Volume-08&issue=ISSUE-06)

Title: **ACCIDENT PREVENTION SMART CAR BASED ON IOT**

Volume 08, Issue 06, Pages: 159–165.

Paper Authors

Ruchitha Kumar, Yashas S, Nithin N, Ranjitha R

RRCE, Bengaluru.



USE THIS BARCODE TO ACCESS YOUR ONLINE PAPER

To Secure Your Paper As Per **UGC Guidelines** We Are Providing A Electronic Bar Code

ACCIDENT PREVENTION SMART CAR BASED ON IOT

Ruchitha Kumar⁽¹⁾, Yashas S⁽²⁾, Nithin N⁽³⁾, Ranjitha R⁽⁴⁾

^{1,2,3,4} UG scholars, Department of ECE, Bengaluru

ABSTRACT

Technology is made to make life simpler and much compatible than it was, everyday every second there is a new technology which is emerging with the same motto. We in this paper trying to give a preventive measures regarding road accidents caused due to abnormal health conditions i.e. increase in heart rate beyond normal conditions, driver drowsiness, high dosage of alcohol consumption and driving or continuously drinking while driving which also leads to high dosage of alcohol consumption, also checked if driver is responsible through eligibility of authorized cards like LL and DL, antitheft system is also given access to the car owner and a panic button is enabled for any person in car to use in emergency situations.

KEYWORDS

GPS (Global Positioning System), GSM (Global Service for Mobile), DL (Driving License), LL (Learning License), RFID (Radio Frequency IDentification).

1. INTRODUCTION

In this paper, we consider both primary and major cause for accidents occurring in our day to day life, by giving an approach as to how accidents can be avoided in some particular situations which causes major percentage of total road accidents. Mainly accidents are caused due to negligence of drivers like high dosage of alcohol consumption even though the police check many go unnoticed so to overcome this biggest problem sensors are placed inside the car as soon as the person enters if he has drunk beyond threshold level given the driver is not allowed to drive the car or in the other way if he starts to drink while driving and if it crosses threshold level the car speed automatically slows down. The

seat belt is plugged or not is checked if not plugged driver cannot start the car, to start car driver needs to scan DL or if he has LL a DL holder should also scan to start the car. The heart rate is continuously monitored and if any abnormal conditions detected it is informed to nearest hospital and to an emergency number with location of the car and hospital also gets a call. Then the driver's face is continuously monitored and detects if the driver is sleepy and gives buzzer alert, if the driver is not concentrating on the road and is distracted by any external factors even then the alert is given to make the driver concentrate on the road. A panic button is given for any emergency purpose and if pressed 3 beeps of

buzzer alert is given to indicate the problem inside the car to outsiders. Anti-thefting option is given where just by sending

CAR_LOCATION the location of car is obtained to owner's number same way he can stop car too the same way.

2. PROPOSED METHODOLOGY

The proposed methodology is streamed towards the safety of the auto motives by providing a solution to human error causing accidents, even if vehicles are flawless human errors result in deadly sequence. In this methodology the system gets initialized and processes the parameters like alcohol consumption, seat belt monitoring, scanning

the measures it constantly if the consumption level of the alcohol is low then next parameter is allowed to checked that is seat belt monitoring, whether the seat belt is plugged or not, if plugged then scanning of DL and LL cards is done, if seat belt is not plugged the system will not initialize to further parameters.

The RFID reader scans the DL or LL cards in order to start the car, if the valid DL card is scanned the car starts and moves and if an invalid card is scanned then the car won't start. In some cases where a driver as valid LL card holder as to drive the car first he must scan the LL and a valid DL and also at the same time to get the confirmation to start the car.

Heart beat sensor continuously monitors the heart rate of the driver, if any abnormal condition is found while driving an SMS alert and a call is sent to the authorized person using GSM module and an emergency alert is sent to the nearest hospital where the SMS alert contains the location of the car using GPS. During driving the car if the consumptions of alcohol is detected and found above the threshold value the speed of the car reduces so that the driver can control the car in order to avoid the accidents

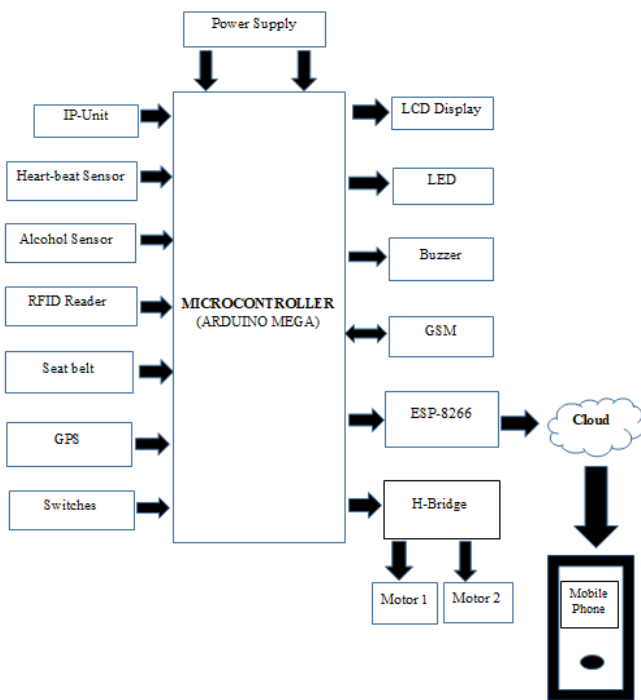

of DL and LL cards, heart rate monitoring

Figure: Block diagram of the proposed system.

and driver monitoring system When the driver gets in to the car the alcohol sensor detects the consumption of alcohol level and

Driver Monitoring System is used with image processing unit via MATLAB software, to detect the drivers face and monitor the face components to judge the driving concentration and also eye blink rate is simultaneously monitor to check for

driver drowsiness level provided with necessary alert.

After all the parameters are monitored the Arduino microcontroller sends the data to the Wi-Fi module which access the cloud, monitored via android application.

3. RESULTS



Figure1: Initially alcohol is detected and further doesn't allow scanning DL or LL also the seat belt.



Figure2: Scan for DL and status of seat belt and alcohol consumption level.



Figure3: Alcohol level detected while driving and automatically car speed slows down



Figure4: If Alcohol isn't detected while driving then the speed is kept normal, Heart rate monitoring.

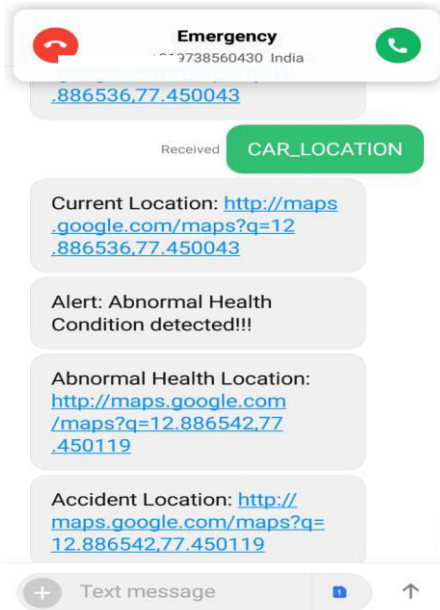

Figure5: Emergency number getting call and alert messages.

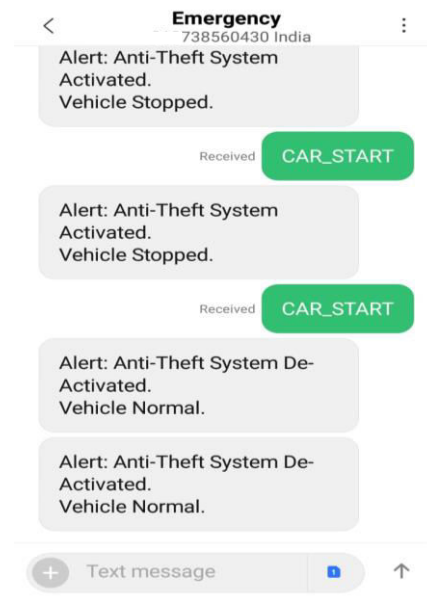

Figure6: Car handling by owners number which helps in anti theft control.

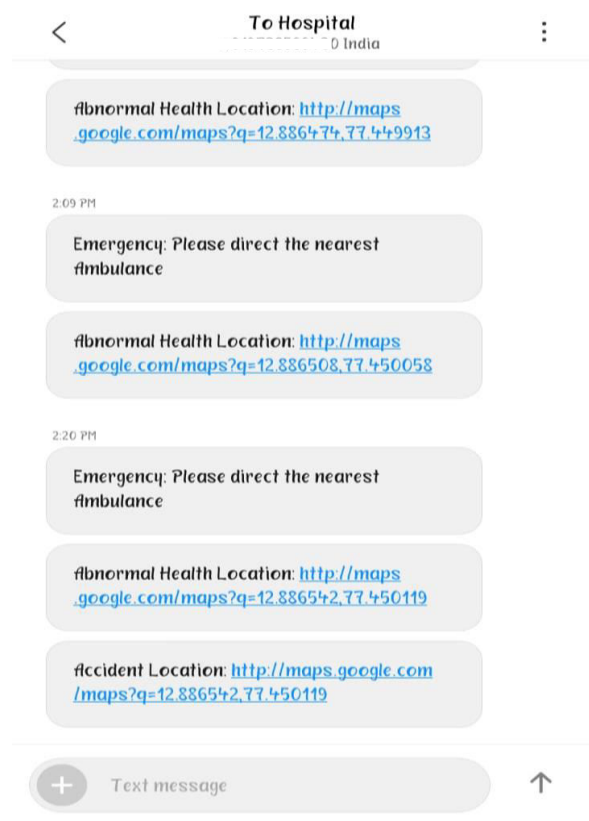
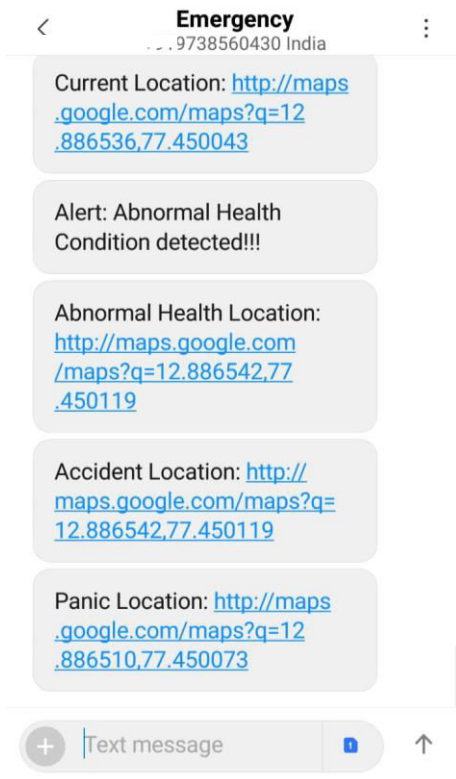

Figure7: Emergency number receiving panic location.

Figure8: Location and emergency message sent to nearest hospital from accident or abnormal health detected location.

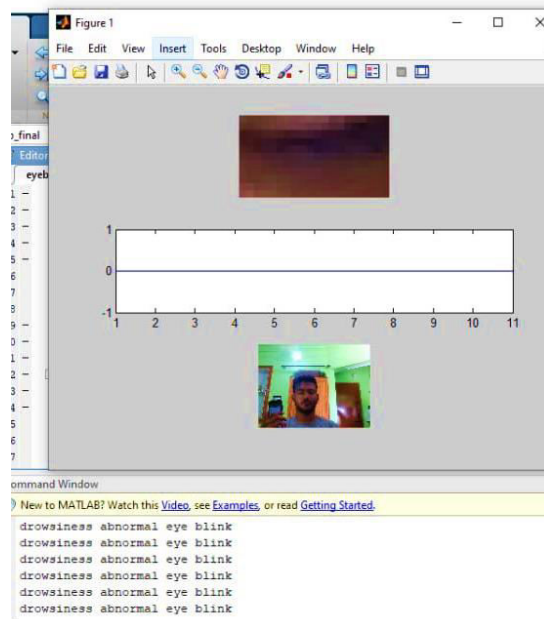
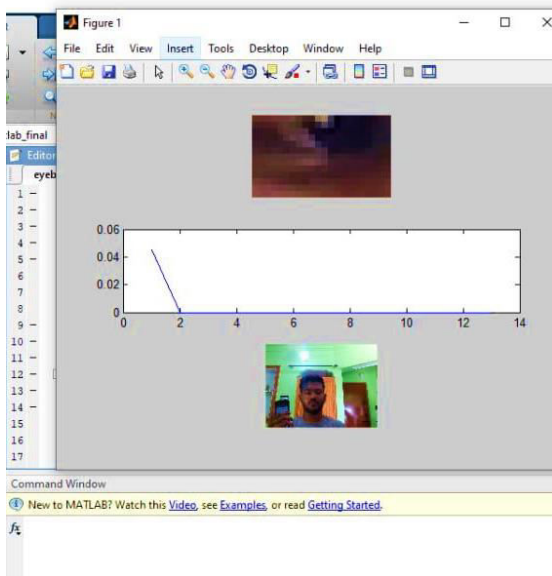

Figure9: Image processing to monitor drowsiness, figure shows driver is awake.

Figure10: Drowsiness alert when the driver is asleep or closes eyes more than a delay given.

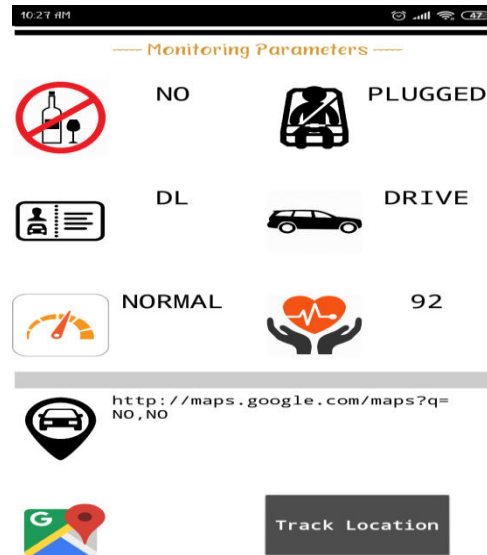
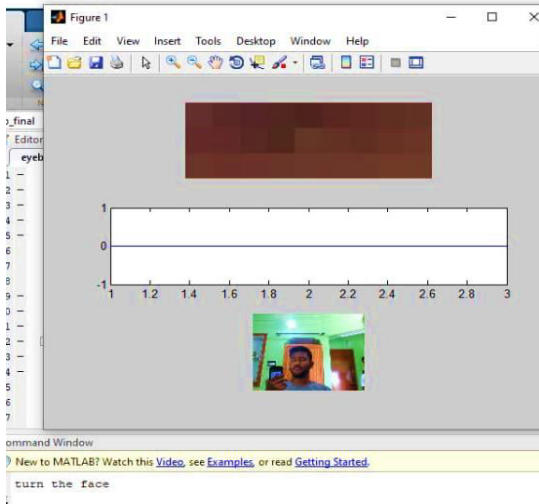

Figure11: Driver monitoring when he is distracted and not concentrating on road.

Figure12: Smart application

4. CONCLUSION

THE smart automotive car is designed using Arduino microcontroller and IoT in order to reduce the accidents caused due to abnormal conditions and driver's error, which helps in saving lives. By this implementation: If high dose of alcohol is recognised it doesn't allow driver to drive and then if alcohol is detected during driving the speed of the car slows down. After detection of heart attack, an emergency alarm is automatically made the authorized person will get location and call an automatic call from the location is sent to nearest hospital giving the location of car present near hospital. The system also provides an additional feature that concentrates on anti-theft that can be controlled by mobile.

As the status of driver is continuously monitored and being updated to cloud. It can be verified from time to time to know the status or condition of the driver as well as the car.

5. REFERENCE

1. Chinthasandeep, ChagantiMounica, N Mounica Reddy, M Pradhyumna
“Implementation of driver drowsiness alter and automatic vehicle control system using Arduino”, *International journal of advanced engineering and research development* (2018).

2. Md. Asaduzzaman Miah, Mir

HussainKabir, SiddiquRahamanTanveer, M A H Ahkand **“Continuous heart rate & body temperature monitoring system using Arduion UNO & Arduino device”**

International conference of electrical information & communication technology(2015).

3. Pughazendi N, Sathish Kumar R, Balaji S, Sathyavenkateshwaren S, SubhashChander S

and Surendar V **“heart attack and alcohol detection sensor monitoring in smart transportation system using IoT”**

International conference on energy, communication, data analytics & soft computing(2017).

4. Sara Fatima, AmenaSayeed **“IoT based health care monitoring & tracking system using GPS and GSM technologies”**

International journal of professional engineering studies (2017).

5. Miss. K Iswarya, Miss. D Devaki, Mr. E Ranjith **“Road assistant system using GPS”** *International journal of advance research, Ideas & innovations in technology* (2017).

6. R Punitha, G Suchithra, A Sujitha **“Automatic car control during heart attack with an emergency messaging and**



comprehensive health monitoring system”
International journal of scientific and engineering research (2015).

7. SahilJithesh “**Antilock braking system”** *International journal of mechanical engineering and robotic research (2014).*

8. V Padmaja, VarshaGoud “**Vehicle accident automatic detection and remote alarm device”** *International journal of*

reconfigurable and embedded system (2012).

9. Boon-Giin Lee and Wan-Young Chung” **Driver Alertness Monitoring Using Fusion of Facial Features and Bio-Signals”.**

10. Y. S. Lee and W. Y. Chung.“**Video sensor-based eye tracking and blink detection to automated drowsy driving warning system using image processing”.**