



International Journal for Innovative Engineering and Management Research

A Peer Reviewed Open Access International Journal

www.ijiemr.org

COPY RIGHT



ELSEVIER
SSRN

2021 IJEMR. Personal use of this material is permitted. Permission from IJEMR must be obtained for all other uses, in any current or future media, including reprinting/republishing this material for advertising or promotional purposes, creating new collective works, for resale or redistribution to servers or lists, or reuse of any copyrighted component of this work in other works. No Reprint should be done to this paper, all copy right is authenticated to Paper Authors

IJEMR Transactions, online available on 13th April 2021.

Link: <https://ijiemr.org/downloads/Volume-10/Issue-4>

DOI: 10.48047/IJEMR/V10/I04/41

Title: **CALCULATION TECHNICAL PARAMETERS OF LONGITUDINAL PAWL-CREATING DEVICE OF WORKING BETWEEN COTTON ROWS**

Volume 10, Issue 04, Pages: 161-164.

Paper Authors:

Olimov Hamid Haydarovich¹, Sobirov Komil Sodiq ugli²



USE THIS BARCODE TO ACCESS YOUR ONLINE PAPER

To Secure Your Paper As Per **UGC Guidelines** We Are Providing A Electronic Bar Code

CALCULATION TECHNICAL PARAMETERS OF LONGITUDINAL PAWL-CREATING DEVICE OF WORKING BETWEEN COTTON ROWS

Olimov Hamid Haydarovich¹, Sobirov Komil Sodiq ugli²

¹PhD of technical scenes, Docent of Bukhara branch of the Tashkent Institute of Irrigation and Agricultural Mechanization Engineers, the Republic of Uzbekistan

²Student of 2nd course of Bukhara branch of the Tashkent Institute of Irrigation and Agricultural Mechanization Engineers, the Republic of Uzbekistan

E-mail: holimov@mail.ru, E-mail: sobirovkomil684@gmail.com

Abstract: This article outlines the results of the theoretical research on the basis of the parameters of the working organs of the parameters of the construction of longitudinal pawl-creating device between cotton rows.

Keywords: Pawl, coil conveyor, rising of soil corner, rotation number of coil conveyor, soil size

Introduction

Today, a considerable part of cotton production is organized by irrigated farming. Not considering that in irrigated farming there is used more expenses of labor base than other types, fertility is considered to be preferable. In some parts of the country, for example, in the Republic of Karakalpakstan, Bukhara, Khorezm, Kashkadarya, and Navai regions, depending on the relief of the cultivated areas and the rough foams will contribute to irrigate the cotton plants by means of longitudinal and transverse pawls. This will help to decrease water consumption in the uneven fields and increase cotton fertility by full watering. In this process, the longitudinal and transverse pawls are formed before primary irrigation and the fact that the longitudinal is preserved for using till the end of the sowing period, it is considered to be high quality and should be considered all agro technical requirements. To date, some farmers still have this process based on manual labor. As a solution to this technological process of mechanization problem, scientists from the Bukhara branch of the Tashkent Institute of Irrigation and Agricultural Mechanization Engineers (BB TIAME) are carrying out scientific research work on the creation of an active cranked longitudinally shaped Pawling device between the cotton rows.

The proposed device

The proposed device is effective with

many of its advantages, particularly it has not got negative impact on cotton and it has energy efficiency, pawl-creating, and other advantages.

The scheme of the coil conveying pawl device is shown in the 1st figure.

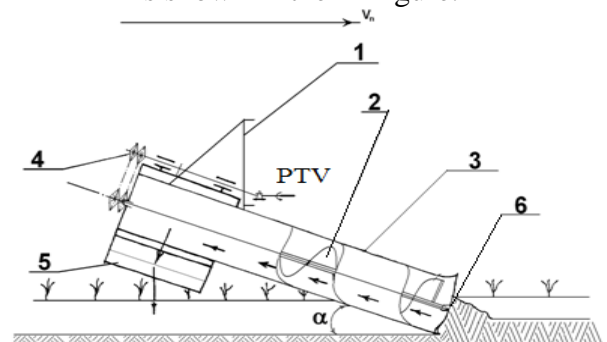

Figure 1. Pawl-creating device between cotton rows

The technological process, using the pawl-creating device, is as follows: at the beginning, when transported through the tie-closer device (1), the soil transported when the particles are assembled on a special bunker (6) at the front of the pipe (3) (2). The crankcase carries through the tractor power take-off valve (PTV) via chain extensions (4) and extends the soil along the saddle pads and reaches the coneshaped forwarding bunker (5) at the end of the pipe. In this process, the soil is sown with the cotton cord, leading to the formation of soil. As a result, a threshold is formed of a set of soil flakes along the row. It is important to determine the height of the floor, the minimum operating temperature of the appliance, the

diameter of the slab, the number of strokes and angles, and the horizontal angle of the horizontally adjusted soil, when the soil is raised with a certain amount of soil moisture.

Using the diagram shown in 2nd figure, we **measure the height of the pawl** relative to the top of the row arcs. According to this

$$h_n = \frac{A}{2} \operatorname{tg} \varphi_m, \quad (1)$$

Where h_n - the height of the pawls between the cotton pumps and the upper part of their arcs; A - the width of the cotton row ($A = 60 \text{ cm}$) φ_m - is the natural shedding of the soil.

According to the data given [1, 30th p, 2, 15th p.] in the literature, if we accept $\varphi_m = 35-40^\circ$, (1) the height of the pawl can be no higher than 25.2 cm.

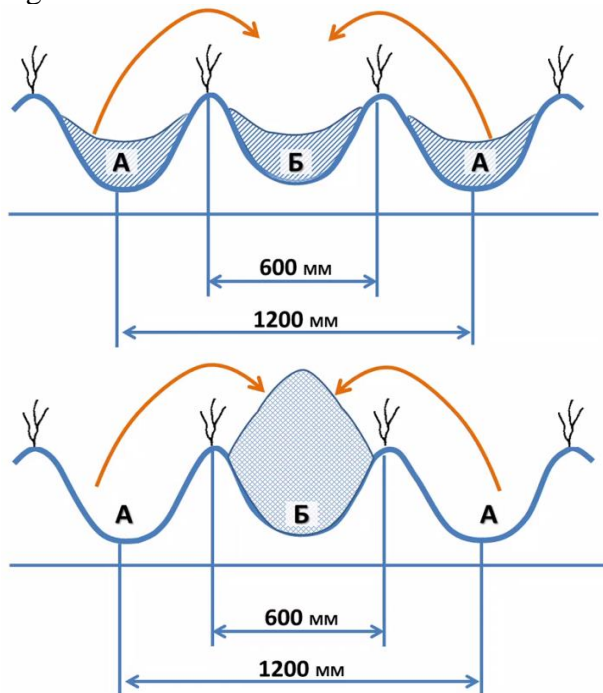

A – lateral furrows with removable soil
B – The furrow where soil builds up and forms the pawl

Picture 2: The process of forming longitudinal pawl between rows of cotton

Now we will determine the face of the transverse pawl. It consists of the sum of two surfaces

$$S_{ym} = S_{\Pi} + S_{\vartheta}, \quad (2)$$

Where S_{ym} - is the surface of the upper triangle;

S_{ϑ} - the face of the bottom flank.

According to the scheme in the 2nd figure

$$S_n = \frac{Ah_n}{2} \quad (3)$$

or considering (1)

$$S_n = \frac{A^2}{4} \operatorname{tg} \varphi_m. \quad (4)$$

Depending on the transformation of the cross-sectional view of the cotton rows into the law

$$z = \frac{h_{\vartheta}}{2} \cdot \left(1 - \sin \frac{2\pi x}{m}\right),$$
 we determine S_{ϑ} by

the following expression

$$S_{\vartheta} = \int_0^A \frac{h_{\vartheta}}{2} \cdot \left(1 - \sin \frac{2\pi x}{m}\right) dx = \frac{h_{\vartheta}}{2} A \quad (5)$$

where h_{ϑ} is the depth of the row of cotton, m (4) and (5), the expression (2) has the following appearance:

$$S_{ym} = \frac{A^2}{4} \operatorname{tg} \varphi_m + \frac{h_{\vartheta}}{2} A = \frac{A}{2} \left(\frac{A}{2} \operatorname{tg} \varphi_m + h_{\vartheta}\right) \quad (6)$$

The calculations made by formula (6) show that the width of the cotton rows is 0.6m and the depth of the furrow is 0.12m, and the surface of the cross-section of the longitudinal cross-section constitutes the sum = 0.099m² (990 cm²).

Determining the minimum operating range of the coil conveyor mechanism

We determine the minimum operating efficiency of the coil conveyor making device

$$Q_{\min} \geq 1000 S_{ym} \vartheta_{mp}, \text{ m}^3/\text{hour} \quad (7)$$

or

$$Q_{\min} \geq 1000 S_{ym} \vartheta_{mp} \rho, \text{ kilo}/\text{hour} \quad (8)$$

where ϑ_{tp} – is the speed of the tractor, km/hour

ρ - soil density, kg/m³

Conclusion

$S_{y,m}=0,099 \text{ m}^2$, $g_{tp}= 4,26 \text{ km/hour}$. [3. 241st p.] ва $\rho=1200$ [4. 13th p.] the minimum operating efficiency of the coil conveyor making device is $Q_{min}=421,7 \text{ m}^3/\text{hour}$ or $Q_{min}=506 \text{ t/hour}$. Based on this value, you can define the parameters of the coil conveyed worker unit.

The results of the above theoretical research enable to define the parameters of the coil conveyed device used for the longitudinal pawls between the cotton rows.

Literature:

1. Romikin N.E. Construction and calculation of conveyors. - Stary Oskol: TNT, 2011. -502 p.
2. Romikin N.E. Romikin D.N. Continuous vehicles. Tutorial. Sarat. State Tech. Univ - Saratov. 1998. -78 p.
3. Handbook on cotton mechanization - Tashkent: Uzbekistan. 1981. - 283 s.
4. Sergienko V.A. Technological basis of mechanization of tillage in between rows of cotton. Tashkent: Fan. 1978. - 112 p.
5. Murodov N.M. Olimov H.H. Murtazoev A.N. Abdullaeva N.I. Studying the technologic process of the operating element for assembly of pawls formation // European Science Review. – Austria. – Vienna, – № 9-10. 2018. – pp. 201-204. (05.00.00; № 3).
6. Olimov H.H. Murodov N.M. Murtazoev A.N. Abdualiev N.H. Found parameters of the construction of longitudinal pawl-creating device between cotton rows // International journal of advanced research in science, engineering and technology. –India, (IJARSET). – Vol. 6, Issue 1. January 2019. – pp. 7885-7887. (05.00.00; № 8).
7. Olimov H.H. Ergashov Z.J. Juraev A.N. Technical calculation screw parameters of the screw construction of working between cotton rows // International journal of advanced research in science, engineering and technology. – India, (IJARSET). – Vol. 6, Issue 2. February 2019. – pp. 7885-7887. (05.00.00; № 8).
8. Patent UzR FAP 00671. Device for longitudinal pawl between cotton rows/ Murodov N.M., Olimov H.H., Shodiev H.N., Haydarov I.G. // Official newsletter. - 2011. - № 4. – P. 3-4.
9. Khamidov, F.R., Imomov, S.J. Abdisamatov, O.S. Sarimsaqov, M.M. Ibragimova, G.Kh. Kurbonova, K.I. Optimization of agricultural lands in land equipment projects // Journal of Critical Reviews Volume 7, Issue 11, 2020, Pages 1021-1023
10. Z.A. Artukmetov, H.Sh. Sheraliev. *Basics of crop irrigation*. // "National Society of Philosophers of Uzbekistan". T. 2007 y. Textbook for university students. 312 b.
11. B.A. Dospexov *Methodology of field testing*.// - Moscow: Kolos, 1979. -416 p.
12. Sergienko V.A. *Technological basis of mechanization of tillage in between rows of cotton*. - Tashkent: Fan, 1978. - 112 p
13. *Handbook of cotton mechanization* - Tashkent: Uzbekistan. 1998. - 283 p.
14. Kh. Kh. Olimov. "Founding technological process and parameters of longitudinal pawl maker device between cotton rows" // PhD diss. Tashkent. 2019.
15. N.M. Murodov, Kh. Kh. Olimov, A.N. Murtazoev. Issues of mechanization of the technological process of forming a pawl between the rows of cotton. // *Talented youth of Bukhara. Popular scientific journal*, Bukhara, 2011. - № 2, - B. 46-49.
16. Kh.Kh. Olimov. N.M. Murodov. A.N. Murtazoev. N.H. Abdualiev. Found parameters of the construction of longitudinal pawl-creating device between cotton rows // *International Journal Of Advanced Research In Science, Engineering And Technology*.–India, (IJARSET). Vol. 6, Issue 1. January 2019. – pp. 7885-7887.
17. Kh.Kh. Olimov. Z.J. Ergashov. A.N. Juraev. Technical calculation screw parameters of the screw construction of working between cotton rows // *International journal of advanced research in science, engineering and technology*.–India, (IJARSET).–Vol.6, Issue2. February 2019.–pp. 7885-7887.
18. Ermatova, D., Imomov, S., Matmurodov, F. Mathematical modeling of the interaction of the main parts of a wheel tractor

and the numerical determination of the operator's seat oscillation (2020) IOP Conference Series: Earth and Environmental Science, 614 (1).

19. Vafoev, R., Vafoev, S., Akhmedov, S., Imomov, S. Method for sealing ground in trench closed drain (2020) IOP Conference Series: Earth and Environmental Science, 614 (1).

20. Marupov, I., Imomov, S., Ermatova, D., Majitov, J., Kholikova, N., Tagaev, V., Nuritov, I. Research of vertical forces for acting tractor unit (2020) IOP Conference Series: Earth and Environmental Science, 614),

21. Sharipov, L.A., Imomov, S.J., Majitov, J.A., Komilov, O.S., Sharipov, M.Z., Pulatova, F., Abdisamatov, O.S. Modeling of heat exchange processes in the Metanetka bioenergy plant for individual use (2020) IOP Conference Series: Earth and Environmental Science, 614 (1).

22. O. Salimov, Sh. Imomov, Z. Mamadalieva. Methodology for assessing the reliability of biogas plants operating under rarefaction conditions/ / Irrigatsiya va melioratsiya, 2018, Mahsus son - pp. 106-110.