



International Journal for Innovative Engineering and Management Research

A Peer Reviewed Open Access International Journal

www.ijiemr.org

COPY RIGHT



ELSEVIER
SSRN

2022 IJIEMR. Personal use of this material is permitted. Permission from IJIEMR must be obtained for all other uses, in any current or future media, including reprinting/republishing this material for advertising or promotional purposes, creating new collective works, for resale or redistribution to servers or lists, or reuse of any copyrighted component of this work in other works. No Reprint should be done to this paper, all copy right is authenticated to Paper Authors

IJIEMR Transactions, online available on 12th Nov 2022. Link

[:http://www.ijiemr.org/downloads.php?vol=Volume-11&issue=Issue 12](http://www.ijiemr.org/downloads.php?vol=Volume-11&issue=Issue 12)

DOI: 10.48047/IJIEMR/V11/ISSUE 11/33

Title **SOLAR TRACKER FOR ACQUIRING MAXIMUM OF POWER**

Volume 11, ISSUE 11, Pages: 228-234

Paper Authors

**T. Sivaram, Shaik Ajeemunnisha, Kashaboina Sairam, Komsani Sai Sreekar Reddy,
Appala Shravan Kumar Yadav**



USE THIS BARCODE TO ACCESS YOUR ONLINE PAPER

To Secure Your Paper As Per **UGC Guidelines** We Are Providing A Electronic Bar Code

SOLAR TRACKER FOR ACQUIRING MAXIMUM OF POWER

T. Sivaram¹, Shaik Ajeemunnisha², Kashaboina Sairam², Komsani Sai Sreekar Reddy², Appala Shraavan Kumar Yadav²

^{1,2}Department of Electrical and Electronics Engineering

^{1,2}Malla Reddy Engineering College and Management Sciences, Medchal, Telangana

ABSTRACT

The goal of this thesis was to develop a laboratory prototype of a solar tracking system, which is able to enhance the performance of the photovoltaic modules in a solar energy system. The operating principle of the device is to keep the photovoltaic modules constantly aligned with the sunbeams, which maximizes the exposure of solar panel to the Sun's radiation. As a result, more output power can be produced by the solar panel. The work of the project included hardware design and implementation, together with software programming for the microcontroller unit of the solar tracker. The system utilised an ATmega328P microcontroller to control motion of two servo motors, which rotate solar panel in two axes. The amount of rotation was determined by the microcontroller, based on inputs retrieved from four photo sensors located next to solar panel. At the end of the project, a functional solar tracking system was designed and implemented. It was able to keep the solar panel aligned with the sun, or any light source repetitively. Design of the solar tracker from this project is also a reference and a starting point for the development of more advanced systems in the future. In this project we propose single axis solar tracking system by which it is possible to catch maximum amount of solar energy by using Arduino as main processing unit. This project we implemented using LDR, dc motor and arduino microcontroller.

Keywords: Solar tracking system, photovoltaic modules, ATmega328P microcontroller.

1. INTRODUCTION

Solar energy is an unlimited source of energy which if harnessed properly will get the mankind devoid of using the conventional sources of energy he has been long using. This project has been designed keeping this in view to make the harnessing of solar energy more efficient. A photovoltaic module is a packaged, connect assembly of typically 6x10 photovoltaic solar cells. Photovoltaic modules constitute the photovoltaic array of a photovoltaic

system that generates and supplies solar electricity in commercial and residential applications. Each module is rated by its DC output power under standard test conditions, and typically ranges from 100 to 365 Watts (W). The efficiency of a module determines the area of a module given the same rated output – an 8% efficient 230 W module will have twice the area of a 16% efficient 230 W module. There are a few commercially available solar modules that exceed efficiency of 22% and reportedly also exceeding 24%. A single solar module can



produce only a limited amount of power; most installations contain multiple modules. A photovoltaic system typically includes an array of photovoltaic modules, an inverter, a battery pack for storage, interconnection wiring, and optionally a solar tracking mechanism.

In the present senerio the variation in the climatic changes have reached the critical level. The main reasons for climatic changes are due to natural causes and man-made destructions like global warming and greenhouse gases are affecting the climatic conditions around the world. In the past decade of years there is increase in demand for reliable and abundant electrical energy derived from renewable energy sources renewable energy plays important role in energy crisis of country. The government started to decrease the usage of conventional energy sources and encouraging people to use renewable energy sources like hydro and solar. One such example of renewable energy is solar power. Solar energy is a very large, inexhaustible souce of energy. The reason is sun is only source we can find anywhere it anywhere. The solar power received by the earth is approximately 1.8×10^{11} MW. The system will tend maximize the amount of power Absorbed by Photo voltaic systems. It has been found that making the use of a Dual axis tracking system, over a fixed system, can increase the power output by 40% - 60%. Solar energy systems have emerged as a possible source of renewable energy over the past two or three decades, and are now utilized for a variety of household and industrial applications. Such systems are based on a

solar collector, it designed to collect the sun's energy and to convert it into either electrical power or thermal energy. In general, the power developed in such applications depends upon the amount of solar energy captured by the collector, and thus the difficulty of developing tracking schemes capable of following the trajectory of the sun throughout the course of Arduino is an open-source computer hardware and software company, project, and user community that designs and microcontroller kits for building digital devices and interactive objects that can sense and control objects in the physical world. The project's products are distributed as open-source hardware and software, which are licensed under the GNU Lesser General Public License or the GNU General Public License permitting the manufacture of Arduino boards and software distribution by anyone. Arduino boards are available commercially in preassembled form, or as do-it-yourself kits. The name Arduino comes from a bar in Ivrea, Italy, where some of the founders of the project used to meet. The bar was named after Arduino of Ivrea, who was the margrave of the March of Ivrea and King of Italy from 1002 to 1014.

Solar energy is a clean, easily accessible and abundantly available alternative energy source in nature. Getting solar energy from nature is very beneficial for power generation. Using fixed Photovoltaic panels extract maximum energy only during 12 noon to 2 PM in Nigeria which results in less energy efficiency. Therefore, the need to improve the energy efficiency of PV solar panel through building a solar tracking

system cannot be over-emphasized. Photovoltaic panels must be perpendicular with the sun in order to get maximum energy. The methodology employed in this work includes the implementation of an Arduino based solar tracking system. Light Dependent Resistors (LDRs) are used to sense the intensity of sunlight and hence the PV solar panel is adjusted accordingly to track maximum energy. The mechanism uses servo motor to control the movement of the solar panel. The microcontroller is used to control the servo motor based on signals received from the LDRs. The result of this work has clearly shown that the tracking solar panel produces more energy compared to a fixed panel.

2. LITERATURE SURVEY

This chapter aims to provide a brief knowledge of Solar Panel, Solar Tracker and the components which made up Solar Tracker. A solar cell is a device which converts light energy to electrical energy through photovoltaic effect. Solar cells are the building blocks of photovoltaic modules known as solar panels. In solar tracking system, the module's surface tracks the position of the sun automatically as the day runs by. The position of the sun varies as the sun moves across the sky. For a solar powered equipment to work best, it must be placed near the sun and the solar tracker can increase the efficiency of that equipment at any fixed position. Based on sophistication, costs and performance. One common type of tracker is the heliostat, a movable mirror that reflects the position of the sun to a fixed location. A solar trackers accuracy depends

on the application. Concentrators, especially in solar cell applications, require a high degree of accuracy to make sure that the concentrated sunlight is directed exactly to the powered device, which is close to the focal point of the reflector or lens. Without tracking, concentrator systems will not work at all, therefore single-axis tracking is mandatory [4]. Non-concentrating applications require less accuracy, and many are likely to work without any tracking. However, tracking with great effect can improve both the amount of total output power produced by a system and that produced during critical system demand periods (usually late afternoon in hot climates) [5]. Research have been done to improve the energy production of solar panels. These research include; double-sided panels [6], conversion stages improvement [7], building panels integration geometrically [8] and so on. Maximum energy is produced by a solar PV panel when it is positioned at right angle to the sun. For this reason, several research developed different types of solar panel tracking systems [9 and 10]. Therefore, the primary purpose of this work is to develop a solar panel tracker based on Arduino advances to enhance the energy production of solar panel.

2.1 Technology of Solar Panel

Solar panels are devices that convert light into electricity. They are called solar after the sun because the sun is the most powerful source of the light available for use. They are sometimes called photovoltaic which means "light-electricity". Solar cells or PV

cells rely on the photovoltaic effect to absorb the energy of the sun and cause current to flow between two oppositely charge layers. A solar panel is a collection of solar cells. Although each solar cell provides a relatively small amount of power, many solar cells spread over a large area can provide enough power to be useful. To get the most power, solar panels must be pointed directly at the Sun. The development of solar cell technology begins with 1839 research of French physicist Antoine-Cesar Becquerel. He observed the photovoltaic effect while experimenting with a solid electrode in an electrolyte solution. After that he saw a voltage developed when light fell upon the electrode.

According to Encyclopaedia Britannica the first genuine for solar panel was built around 1883 by Charles Fritts. He used junctions formed by coating selenium (a semiconductor) with an extremely thin layer of gold. Crystalline silicon and gallium arsenide are typical choices of materials for solar panels. Gallium arsenide crystals are grown especially for photovoltaic use, but silicon crystals are available in less-expensive standard ingots, which are produced mainly for consumption in the microelectronics industry. Norway's Renewable Energy Corporation has confirmed that it will build a solar manufacturing plant in Singapore by 2010 - the largest in the world. This plant will be able to produce products that can generate up to 1.5 Giga watts of energy every year. That is enough to power several million

households at any one time. Last year the world produced products that could generate just 2 GW in total.

2.2 Evolution of Solar Tracker

Since the sun moves across the sky throughout the day, in order to receive the best angle of exposure to sunlight for collection energy. A tracking mechanism is often incorporated into the solar arrays to keep the array pointed towards the sun. A solar tracker is a device onto which solar panels are fitted which tracks the motion of the sun across the sky ensuring that the maximum amount of sunlight strikes the panels throughout the day. When compare to the price of the PV solar panels, the cost of a solar tracker is relatively low. Most photovoltaic solar panels are fitted in a fixed location- for example on the sloping roof of a house, or on framework fixed to the ground. Since the sun moves across the sky though the day, this is far from an ideal solution. Solar panels are usually set up to be in full direct sunshine at the middle of the day facing South in the Northern Hemisphere, or North in the Southern Hemisphere. Therefore, morning and evening sunlight hits the panels at an acute angle reducing the total amount of electricity which can be generated each day.

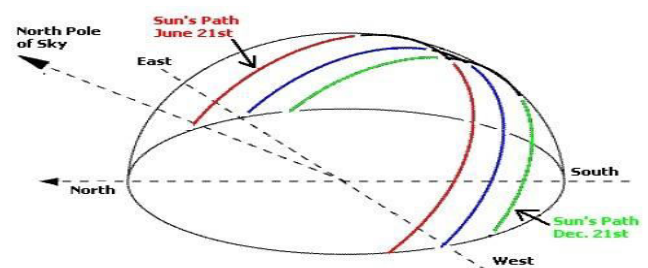

Fig. 1: Sun's apparent motion.

During the day the sun appears to move across the sky from left to right and up and down above the horizon from sunrise to noon to sunset. Fig 1 shows the schematic above of the Sun's apparent motion as seen from the Northern Hemisphere. To keep up with other green energies, the solar cell market has to be as efficient as possible in order not to lose market shares on the global energy marketplace. The end-user will prefer the tracking solution rather than a fixed ground system to increase their earnings because:

- The efficiency increases by 30-40%.
- The space requirement for a solar park is reduced, and they keep the same output.
- The return of the investment timeline is reduced.
- The tracking system amortizes itself within 4 years.
- In terms of cost per Watt of the completed solar system, it is usually cheaper to use a solar tracker and less solar panels where space and planning permit.
- A good solar tracker can typically lead to an increase in electricity generation capacity of 30-50%.

3. PROPOSED SYSTEM

The principle of the solar tracking system is done by Light Dependant Resistor (LDR). Four LDR's are connected to Arduino analog pin AO to A4 that acts as the input for the system. The built-in

Analog-to-Digital Converter will convert the analog value of LDR and convert it into digital.

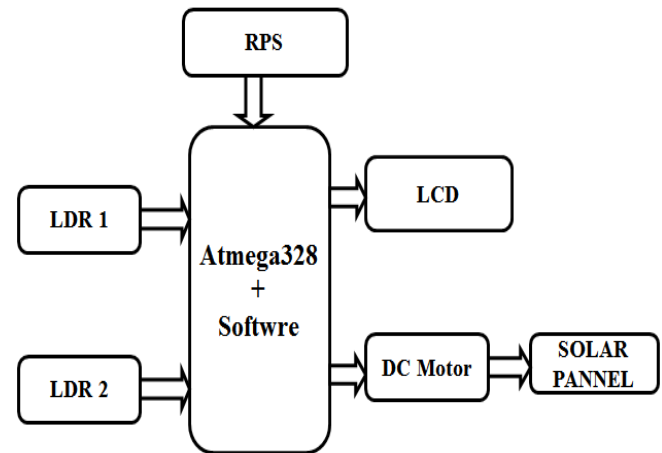

Fig. 2: Block diagram of proposed system.

The inputs are from analog value of LDR, Arduino as the controller and the DC motor will be the output. LDR1 and LDR2 are taken as pair. If one of the LDR in a pair gets more light intensity than the other, a difference will occur on node voltages sent to the respective Arduino channel to take necessary action. The DC motor will move the solar panel to the position of the high intensity LDR that was in the programming.

The proposed following framework does follow of daylight all the more adequately by giving PV board revolution in two diverse pivots. DC engines are essentially performing capacity of sun following. Upper board holder dc engine tracks sun directly, and base stepper engine tracks the allegorical uprooting of sun. These dc engine and sensors are interfaced with a

microcontroller which is controlling dc engines based on sensors input. LDR sensor sense the light and sends flag to microcontroller. Microcontroller is doing correlation of signs got from LDR sensors and based on more grounded signals it is choosing pivot heading of dc engine. Double hub tracker control is clarified with the assistance of piece chart appeared in figure. The square outline demonstrating that LDR sensors subsequent to detecting the light forward the flag to Arduino. Arduino is astute gadget which is taking activities based on sensor information and initiating engine drivers circuit as needs be. Presently assume if sun changes its area and moves from east to west, it will make light force be diverse on one sensor when contrasted with other one. Based on light force contrast on sensor, controller enacts driver circuit and moves dc Motors new position where light falling on sensor sets is same. A similar procedure is kept on with on changes suns area in the sky. Therefore, this proposed demonstrate can catch more sun beams and frameworks sun powered vitality transformation ability is enormously improved.

4. RESULTS AND DISCUSSION

4.1 Arduino IDE

What is Arduino IDE?

The Arduino Integrated Development Environment - or Arduino Software (IDE) - contains a text editor for writing code, a message area, a text console, a toolbar with buttons for common functions and a series of menus. It connects to the Arduino

hardware to upload programs and communicate with them.

A program for Arduino hardware may be written in any programming language with compilers that produce binary machine code for the target processor. Atmel provides a development environment for their 8-bit AVR and 32-bit ARM Cortex-M based microcontrollers: AVR Studio (older) and Atmel Studio (newer).

4.2 Schematic diagram

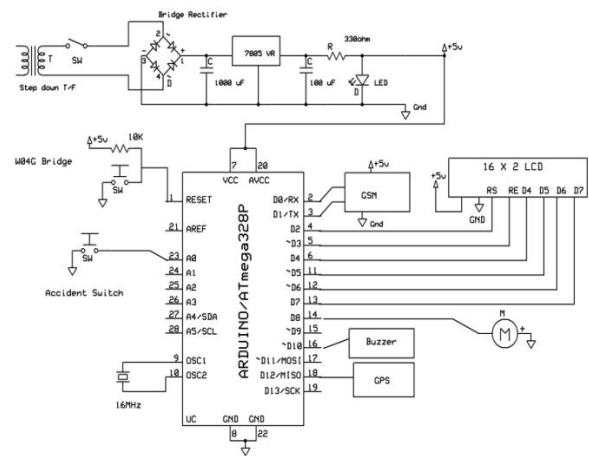

Fig. 3: Schematic diagram of proposed system.

4.3 Hardware implementation

5. CONCLUSION

The proposed dual axis solar tracker automatically tracks position of sun and maximize the solar power with help of arduino. The main aim of this work is to develop Single axis solar tracker system that uses four sensors (ldrs) to predict the sun position. Secondly, program is dumped on to Arduino (ATmega 328 p) so that rotation of servo motor can be controlled by employing

the microcontroller. The programming part consists of 5 cases which has been stated and analyzed. Thirdly, to investigate the voltage differences from the sensor (light depending resistor LDR) based on intensity of light received by the sensor. The output has plotted into a graph and compared with static system. And proposed system is eco-friendly, and widely used.

REFERENCES

- [1] Gonçalves, P.; Orestes, M. Photovoltaic solar energy: Conceptual framework. *Renew. Sustain. Energy* 2017, 74, 590–601.
- [2] M.T.A. Khan, S.M.S. Tanzil, R. Rahman, S.M.S. Alam. "Design and Construction of an Automatic Solar Tracking System." 6th International Conference on Electrical and Computer Engineering ICECE 2010, 18 – 20 December, Dhaka, Bangladesh.
- [3] B. A. Mork, W.W. Weaver, "Smart Grids and Micro Grids, where are they really." Minnesota Power Systems Conference, 3 -5 November 2009, Brooklyn Center, MN, USA.
- [4] A.K. Saxena and V. Dutta, "A versatile microprocessor-based controller for solar tracking," in *Proc. IEEE*, 1990.
- [5] Yousef, H.A. Design and implementation of a fuzzy logic computer-controlled sun tracking system. In *Proceedings of IEEE International Symposium on Industrial Electronics*, Bled, Slovenia, Jul. 12-16, 1999
- [6] Lo, C.K.; Lim, Y.S.; Rahman, F.A. New integrated simulation tool for the optimum design of bifacial panel with reflectors panels on a specific site. *Renew. Energy* 2015, 81, 293–307.
- [7] Van der Meer, D.W.; Widen, J.; Munkhammar, J. Review on probabilistic forecasting of photovoltaic power production and electricity consumption. *Renew. Sustain. Energy Rev.* 2017.
- [8] Spertino, F.; Ahmad, J.; Ciocia, A.; Di Leo, P. Techniques and experimental results for performance analysis of photovoltaic modules installed in buildings. *Energy Procedia* 2017, 111, 944–953.
- [9] Quesada, G.; Guillon, L.; Rouse, D.; Mehrtash, M.; Dutil, Y.; Paradis, P.L. Tracking strategy for photovoltaic solar systems in high latitudes. *Energy Convers. Manag.* 2015, 103, 147–156.
- [10] Miloudi, L.; Acheli, D.; Ahmed, C. Solar tracking with photovoltaic system. *Energy Procedia* 2013, 42, 103–112.